

Octal inverting buffers with 3-state outputs

HEF40240B  
buffers

DESCRIPTION

The HEF40240B is an octal inverting buffer with 3-state outputs. It features output stages with high current output capability suitable for driving highly capacitive loads.

The 3-state outputs are controlled by the output enable inputs  $\overline{EO}_A$  and  $\overline{EO}_B$ . A HIGH on  $\overline{EO}$  causes the outputs to assume a high impedance OFF-state. The device also features hysteresis on all inputs to improve noise immunity.

Schmitt-trigger action in the inputs makes the circuit highly tolerant to slower input rise and fall times.

The HEF40240B is pin and functionally compatible with the TTL '240' device.

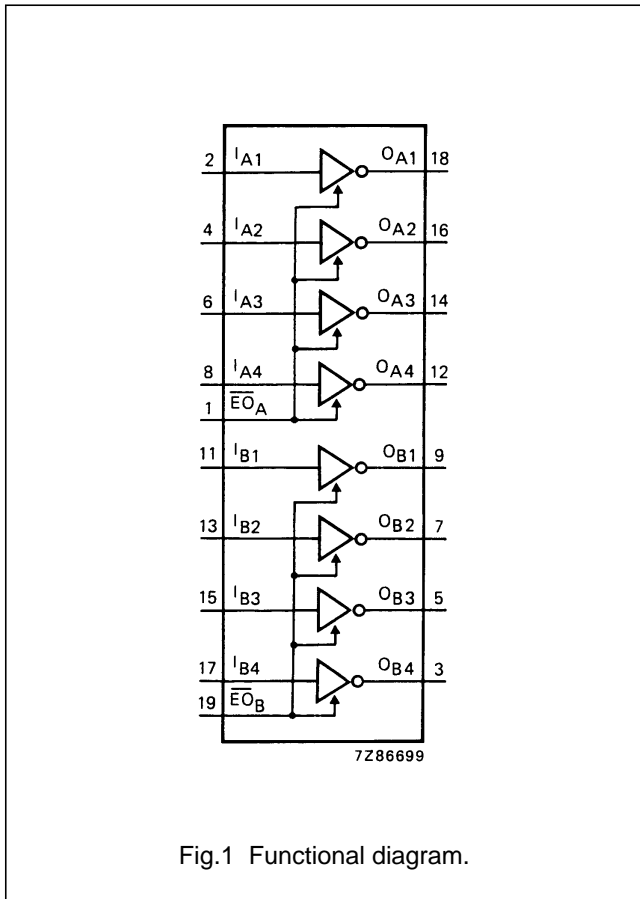

Fig.1 Functional diagram.

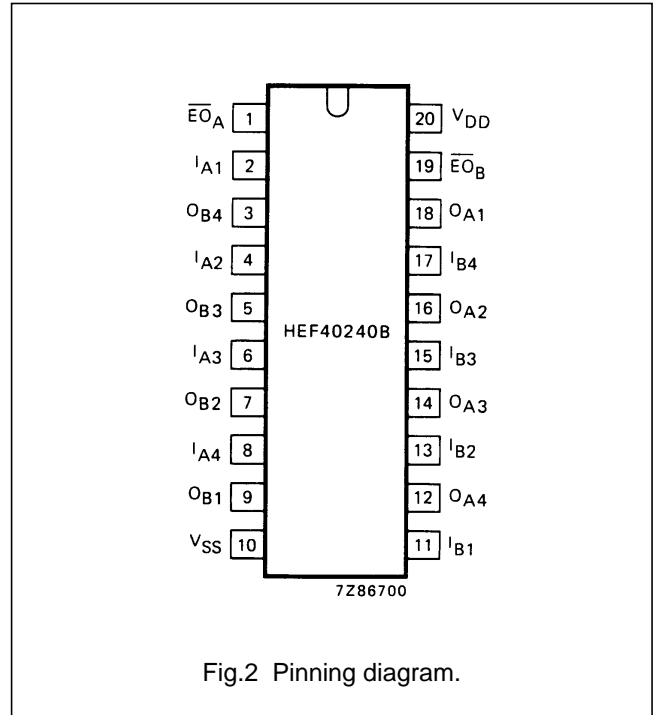

Fig.2 Pinning diagram.

- HEF40240BP(N): 20-lead DIL; plastic (SOT146-1)
- HEF40240BD(F): 20-lead DIL; ceramic (cerdip) (SOT152)
- HEF40240BT(D): 20-lead SO; plastic (SOT163-1)
- ( ): Package Designator North America

PINNING

- IA1 to IA4            inputs
- IB1 to IB4            inputs
- OA1 to OA4           bus outputs
- OB1 to OB4           bus outputs
- $\overline{EO}_A, \overline{EO}_B$         output enable inputs (active LOW)

FAMILY DATA, I<sub>DD</sub> LIMITS category buffers

See Family Specifications

Octal inverting buffers with 3-state outputs

HEF40240B  
buffers

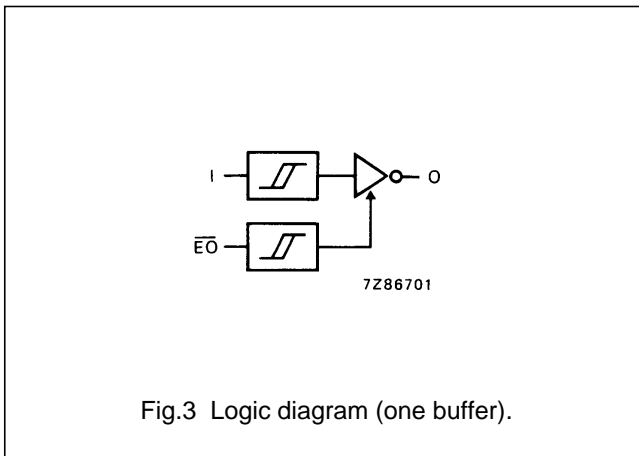

Fig.3 Logic diagram (one buffer).

TRUTH TABLE

INPUTS		OUTPUT
I <sub>n</sub>	$\overline{EO}$	O <sub>n</sub>
H	L	L
L	L	H
X	H	Z

Notes

- H = HIGH state (the more positive voltage)  
L = LOW state (the less positive voltage)  
X = state is immaterial  
Z = high impedance off state

RATINGS

Limiting values in accordance with the Absolute Maximum System (IEC 134)

See Family Specifications except for:

D.C. current into any input	$\pm I_I$	max.	10 mA
D.C. source or sink current into any output	$\pm I_O$	max.	25 mA
D.C. current into the supply terminals	$\pm I$	max.	100 mA

DC CHARACTERISTICS

V<sub>SS</sub> = 0 V

PARAMETER	V <sub>DD</sub>	V <sub>OH</sub>	V <sub>OL</sub>	SYMBOL	T <sub>amb</sub> (°C)						UNIT
					-40		+25		+85		
					MIN.	TYP.	MIN.	TYP.	MIN.	TYP.	
Output current HIGH	5	3,6	-	-I <sub>OH</sub>	9,3	-	10,0	24,0	10,7	-	mA
	10	8,4	-	-I <sub>OH</sub>	14,4	-	15,0	46,0	15,0	-	mA
	15	13,2	-	-I <sub>OH</sub>	19,5	-	20,0	62,0	19,8	-	mA
Output current HIGH	5	4,6	-	-I <sub>OH</sub>	0,75	-	0,6	1,2	0,45	-	mA
	10	9,5	-	-I <sub>OH</sub>	1,85	-	1,5	3,0	1,1	-	mA
	15	13,5	-	-I <sub>OH</sub>	14,5	-	15,0	50,0	15,5	-	mA
Output current LOW	5	-	0,4	I <sub>OL</sub>	2,9	-	2,3	5,4	1,75	-	mA
	10	-	0,5	I <sub>OL</sub>	9,5	-	7,6	17,0	5,50	-	mA
	15	-	1,5	I <sub>OL</sub>	30,0	-	25,0	45,0	19,0	-	mA
Hysteresis voltage (any input)	5	-	-	V <sub>H</sub>	-	-	-	220,0	-	-	mV
	10	-	-	V <sub>H</sub>	-	-	-	250,0	-	-	mV
	15	-	-	V <sub>H</sub>	-	-	-	320,0	-	-	mV