

## 433MHz Single Chip RF Transmitter

## nRF402

### FEATURES

- True single chip FSK transmitter
- Few external components required
- On chip UHF synthesiser
- No set up or configuration
- 20kbit/s data rate
- 2 channels
- Very low power consumption
- Standby mode

### APPLICATIONS

- Alarm Systems
- Automatic Meter Reading (AMR)
- Keyless entry
- Home Automation
- Remote Control
- Surveillance
- Automotive
- Telemetry
- Toys
- Wireless Communication

### GENERAL DESCRIPTION

nRF402 is a true single chip UHF transmitter designed to operate in the 433MHz ISM (Industrial, Scientific and Medical) frequency band. It features Frequency Shift Keying (FSK) modulation capability. nRF402 operates at data rates up to 20kbits/s. Transmit power can be adjusted to a maximum of +10dBm. Antenna interface is differential and suited for low cost PCB antennas. nRF402 operates from a single 3V DC supply and has a standby mode which makes power saving easy and efficient. As a primary application, nRF402 is intended for UHF radio equipment in compliance with the European Telecommunication Standard Institute (ETSI) specification EN 300 220-1 V1.2.1.

### QUICK REFERENCE DATA

Parameter	Value	Unit
Frequency, Channel#1/Channel#2	433.92 / 434.33	MHz
Modulation	FSK	
Frequency deviation	±15	kHz
Max. RF output power @ 400Ω, 3V	10	dBm
Maximum bit rate	20	kbit/s
Supply voltage	2.7 – 3.6	V
Transmit supply current @ -10 dBm RF output power	8	mA
Standby supply current	8	µA

Table 1. nRF402 quick reference data

### ORDERING INFORMATION

Type number	Description	Version
nRF402-IC	14 pin SSOIC	A
nRF402-EVKIT	Evaluation kit with nRF402 IC	1.0

Table 2. nRF402 ordering information



**BLOCK DIAGRAM**

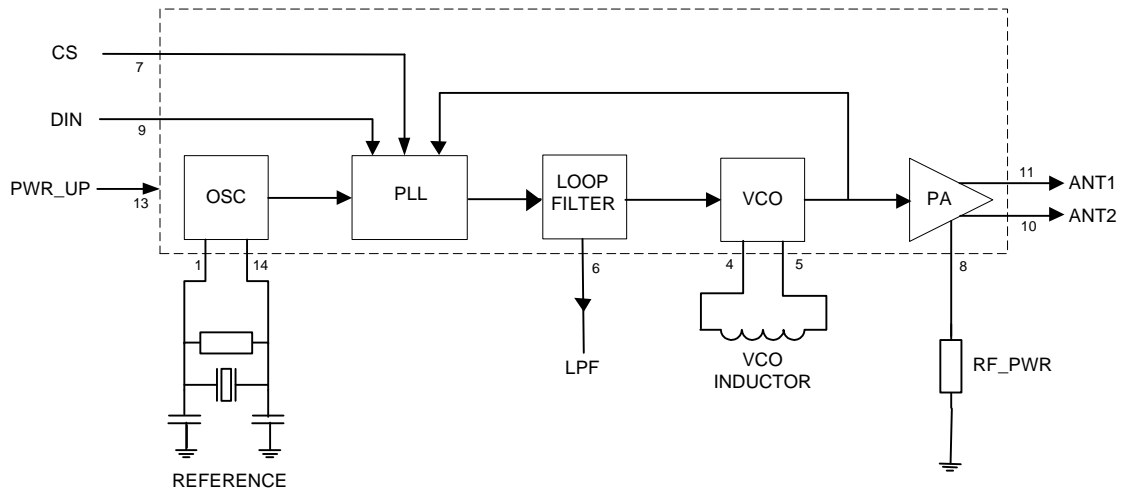

Figure 1. nRF402 block diagram with external components

**PIN FUNCTIONS**

Pin	Name	Pin function	Description
1	XC1	Input	Crystal oscillator input
2	VSS	Ground	Ground (0V)
3	VDD	Power	Power supply (+3V DC)
4	VCO1	Input	External inductor for VCO
5	VCO2	Input	External inductor for VCO
6	LPF	Test	Loop filter voltage test pin *
7	CS	Input	Channel selection CS="0" ⇒ 433.92MHz, (Channel#1) CS="1" ⇒ 434.33MHz, (Channel#2)
8	RF_PWR	Input	Transmit power setting
9	DIN	Input	Data input
10	ANT2	Output	Antenna terminal
11	ANT1	Output	Antenna terminal
12	VSS	Ground	Ground (0V)
13	PWR_UP	Input	Power on/off PWR_UP = "1" ⇒ Power up (Transmit mode) PWR_UP = "0" ⇒ Power down (Standby mode)
14	XC2	Output	Crystal oscillator output

Table 3. nRF402 pin functions

\*) This pin is only for test purposes and is intended for use when measuring the loop filter voltage.



**ELECTRICAL SPECIFICATIONS**

Conditions: VDD = +3V DC, VSS = 0V, TA= -25°C to +85°C

Symbol	Parameter (condition)	Min.	Typ.	Max.	Units
VDD	Supply voltage	2.7	3	3.6	V
VSS	Ground		0		V
IDD	Current consumption in transmit mode @ -10 dBm RF power		8		mA
IDDD	Current consumption in standby mode		8		µA
PRF	Max. RF output power @ 400Ω load		10		dBm
VIH	Logic "1" input voltage	0.7·VDD		VDD	V
VIL	Logic "0" input voltage	0		0.3·VDD	V
IH	Logic "1" input current (VI = VDD)			+20	µA
IL	Logic "0" input current (VI = VSS)			-20	µA
f1	Channel#1 frequency		433.92		MHz
f2	Channel#2 frequency		434.33		MHz
	Modulation type		FSK		
Δf	Frequency deviation		±15		kHz
fXTAL	Crystal frequency <sup>1)</sup>		4.000		MHz
	Bit rate	0		20	kbit/s
Z1	Recommend antenna port differential load impedance		400		Ω
	Spurious emission	Compliant with EN 300-220-1 V1.2.1 <sup>2)</sup>			

Table 4. nRF402 electrical specifications

- 1) Crystal stability requirement must match the receiver requirement. For use with nRF401, the crystal frequency stability should be better than ±45 ppm.
- 2) With PCB loop antenna or differential to single ended matching network to a 50Ω antenna.

**ABSOLUTE MAXIMUM RATINGS**

**Supply voltages**

VDD ..... - 0.3V to +6V  
 VSS ..... 0V

**Total power dissipation**

PD (TA=85°C)..... 230 mW

**Input voltage**

VI..... - 0.3V to VDD + 0.3V

**Temperatures**

Operating Temperature -25°C to +85°C  
 Storage Temperature - 40°C to +125°C

*Note: Stress exceeding one or more of the limiting values may cause permanent damage to the device.*

**ATTENTION!**

Electrostatic Sensitive Device  
 Observe Precaution for handling.





**PIN ASSIGNMENT**

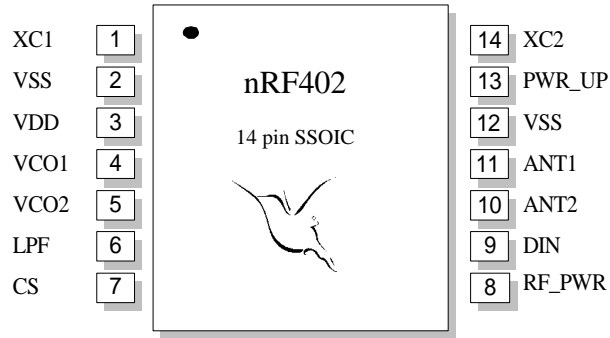
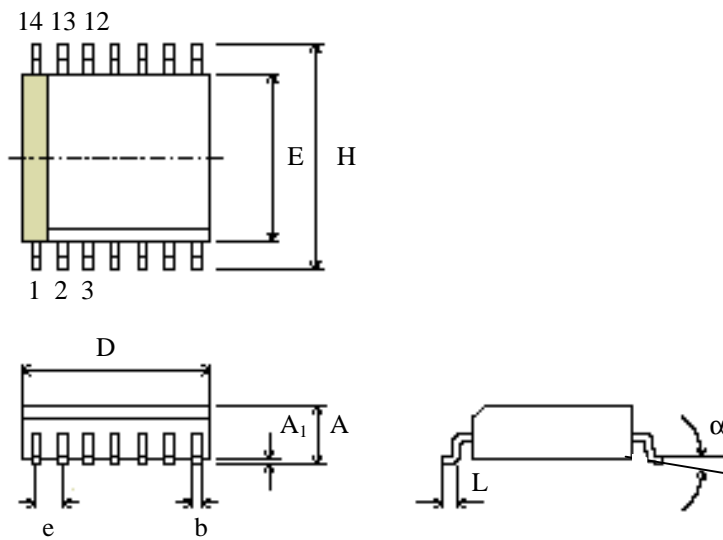

Figure 2. nRF402 pin assignment

**PACKAGE OUTLINE**

nRF402, 14 pin SSOIC. Dimensions in mm



Package Type		D	E	H	A	A <sub>1</sub>	e	b	L	Copl.	α
14 pin SSOIC (5.3 mm)	Min	5.90	5.00	7.40		0.05	0.65	0.22	0.55		0°
	Max	6.50	5.60	8.20	2.00			0.38	0.95	0.10	8°

Figure 3. SSOIC-14 Package outline



## IMPORTANT TIMING DATA

### Timing information

The timing information for the different operations is summarised in Table 5. (TX is transmit mode, Std.by is standby mode.)

Change of Mode	Name	Max Delay	Condition
Std.by → TX	$t_{ST}$	2ms	Operational mode
$V_{DD}=0 \rightarrow$ TX	$t_{VT}$	4ms	Start-up

Table 5 Switching times for nRF402

### Switching between standby and TX-mode.

The maximum time from the PWR\_UP input is set to “1”, until the synthesised frequency is stable is  $t_{ST}$ , see Table 5 and Figure 4.

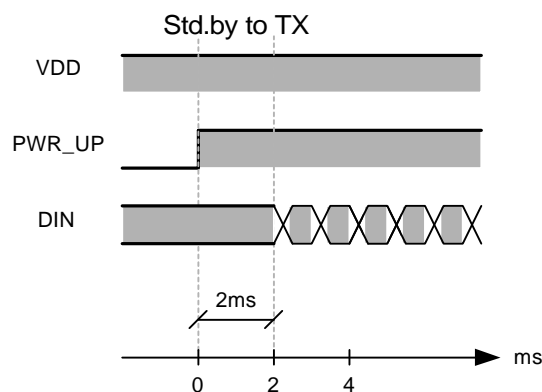

Figure 4 Timing diagram for nRF402 when going from standby to TX-mode

### Powering up to transmit-mode (start-up).

Due to spurious emission when the power supply is switched on, the PWR\_UP-input must be kept low for 2ms after  $V_{DD} > 2.7$  V. Data (DIN) is valid within 2ms after PWR\_UP is high.

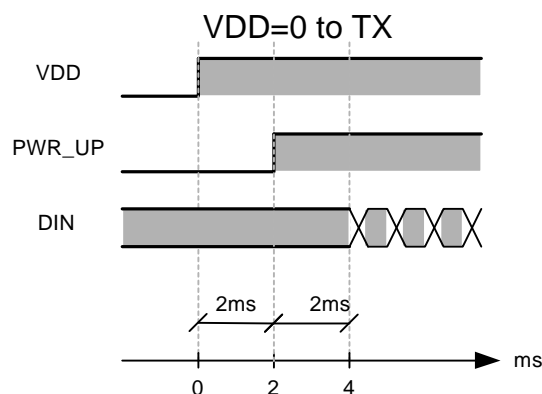

Figure 5. Timing diagram for nRF402, when powering up to TX-mode



## APPLICATION INFORMATION

### Antenna output

The ANT1 and ANT2 pins provide RF output from the output stage (PA) for nRF402. The antenna connection to nRF402 is differential and the recommended load impedance at the antenna port is 400Ω.

Figure 11 shows a typical application schematic with a differential loop antenna on a Printed Circuit Board (PCB). The output stage (PA) consists of two open collector transistors in a differential pair configuration. VDD to the PA must be supplied through the collector load. When connecting a differential loop antenna to the ANT1/ANT2 pins, VDD should be supplied through the centre of the loop antenna as shown in Figure 11.

A single ended antenna or 50Ω test instrument may be connected to nRF402 by using a differential to single ended matching network (BALUN) as shown in Figure 6.

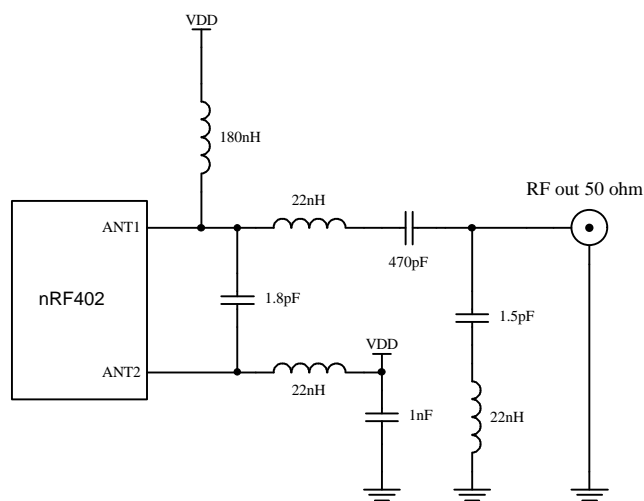

Figure 6. Connection of nRF402 to single ended antenna by using a differential to single ended matching network

The 180nH inductor to VDD in Figure 6, need to have a Self-Resonance Frequency (SRF) above 433 MHz to be effective. Suitable inductors are listed in Table 6.

Vendors	WWW address	Part. no., 180 nH inductors, 0603 size
Stetco	<a href="http://www.stetco.com">http://www.stetco.com</a>	0603G181KTE
Coilcraft	<a href="http://www.coilcraft.com">http://www.coilcraft.com</a>	0603CS-R18XJBC
muRata	<a href="http://www.murata.com">http://www.murata.com</a>	LQW1608AR18J00

Table 6. Vendors and part. no. for suitable 180nH inductors.

A single ended antenna may also be connected to nRF402 using an 8:1 impedance RF transformer. The RF transformer must have a centre tap at the primary side for VDD supply.



**nRF402 Single Chip RF Transmitter**

**RF output power**

The external bias resistor R3 connected between the RF\_PWR pin and VSS sets the output power. The RF output power may be set to levels up to +10dBm. In Figure 7 the output power is plotted for power levels down to, but not limited to, -8.5dBm for a differential load of 400Ω. DC power supply current versus external bias resistor value is shown in Figure 8.

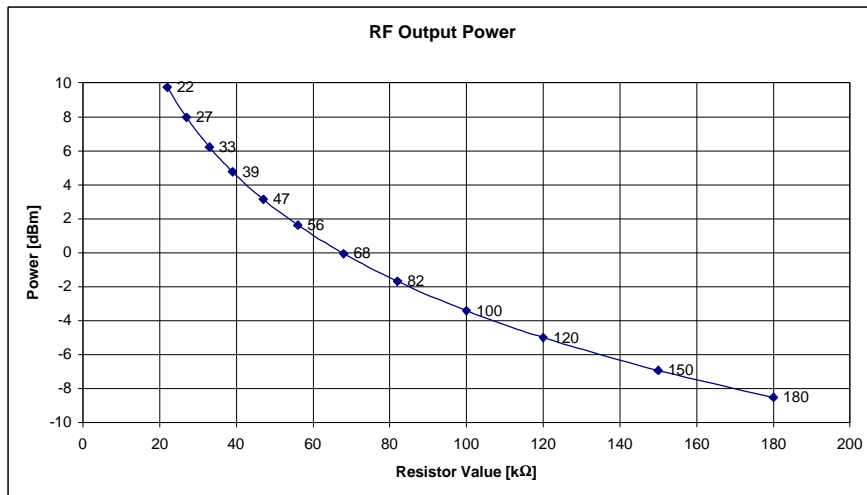

Figure 7. RF Output power vs. external power setting resistor (R3) for nRF402

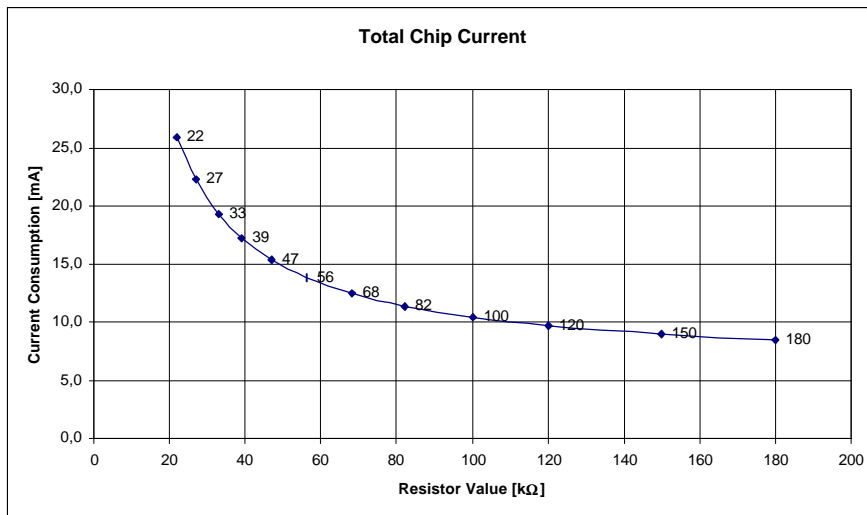

Figure 8. Total chip current consumption vs. external power setting resistor (R3) for nRF402



**VCO inductor**

An external 22nH inductor connected between the VCO1 and VCO2 pins is required for the on-chip voltage controlled oscillator (VCO). This inductor should be a high quality chip inductor,  $Q > 45 @ 433 \text{ MHz}$ , with a maximum tolerance of  $\pm 2\%$ . The following 22 nH inductors (0603) are suitable for use with nRF402, see Table 7.

Vendors	WWW address	Part. no., 22 nH inductors, 0603 size
Pulse	<a href="http://www.pulseeng.com">http://www.pulseeng.com</a>	PE-0603CD220GTT
Coilcraft	<a href="http://www.coilcraft.com">http://www.coilcraft.com</a>	0603CS-22NXGBC
muRata	<a href="http://www.murata.com">http://www.murata.com</a>	LQW1608A22NG00
Stetco	<a href="http://www.stetco.com">http://www.stetco.com</a>	0603G220GTE
KOA	<a href="http://www.koaspeer.com">http://www.koaspeer.com</a>	KQ0603TE22NG

Table 7. Vendors and part no. of suitable 22 nH inductors

See page 10 for PCB layout guidelines regarding placement of the inductor.

**Crystal specification**

To achieve an active crystal oscillator (XOSC) with low power consumption, certain requirements apply for crystal loss and capacitive load.

The crystal specification is:

- $f = 4.0000 \text{ MHz}$       Crystal parallel resonant frequency
- $C_o \leq 5 \text{ pF}$       Crystal parallel equivalent capacitance
- $ESR \leq 150 \text{ ohm}$  .      Crystal equivalent series resistance
- $C_L \leq 14 \text{ pF}$       Total crystal load capacitance, including capacitance in PCB layout.

For the crystal oscillator shown in Figure 9 the load capacitance becomes

$$C_L = \frac{C1' \cdot C2'}{C1' + C2'} \text{ , Where } C1' = C1 + C_{PCB1} \text{ and } C2' = C2 + C_{PCB2}$$

C1 and C2 are 0603 SMD capacitors as shown in the application schematic, see Figure 11 and Table 8.  $C_{PCB1}$  and  $C_{PCB2}$  are the layout parasitic capacitance on the circuit board.



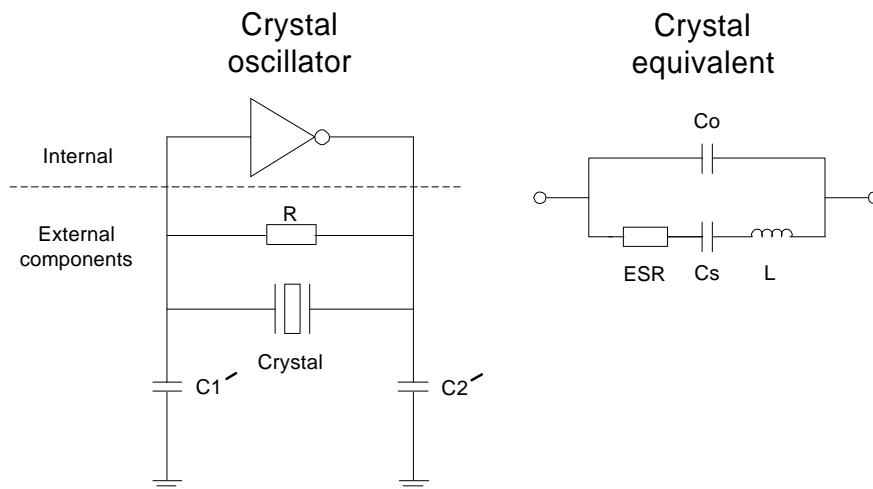

Figure 9. Crystal oscillator and crystal equivalent

**Sharing a reference crystal with a micro-controller**

Figure 10 shows circuit diagram of a typical application where nRF402 and a micro controller share the reference crystal.

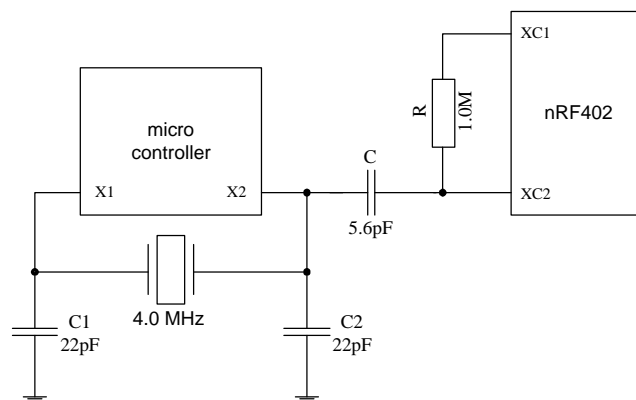

Figure 10. nRF402 and a micro-controller sharing the reference crystal

The crystal reference line from the micro-controller should not be routed close to full swing digital data or control signals.

**Channel#1 / Channel#2 selection**

CS is a digital input for selection of either channel#1 ( $f_1=433.92\text{MHz}$ ) or channel#2 ( $f_2=434.33\text{MHz}$ ).

CS = "0" selects channel#1.

CS = "1" selects channel#2.

**DIN (data input)**

The DIN pin is the input to the digital modulator of the transmitter. The input signal to this pin should be standard CMOS logic level at data rates up to 20 kbit/s.

$$\text{DIN} = "1" \rightarrow f = f_0 + \Delta f$$

$$\text{DIN} = "0" \rightarrow f = f_0 - \Delta f$$



## **nRF402 Single Chip RF Transmitter**

---

### **Power up**

PWR\_UP is a digital input for selection of normal operating mode or standby mode.

PWR\_UP = “1” selects normal operating mode.

PWR\_UP = “0” selects standby mode.

### **LPF pin**

LPF is the loop filter test pin. This may be used for measurement of the loop filter voltage. In a normal application this pin should only be connected to a solder pad. No PCB lines should be connected to this pin.

### **Frequency difference between transmitter and receiver**

Assuming the nRF401 transceiver chip is used for demodulation, the total frequency difference between transmitter and receiver should not exceed 70 ppm (30 kHz). This yields a crystal stability requirement of  $\pm 35$  ppm for the transmitter and receiver. Frequency difference exceeding this will result in a 12dB/octave drop in receiver sensitivity. The functional window of the transmission link is typically 450 ppm (200 kHz).

Example: A crystal with  $\pm 20$  ppm frequency tolerance and  $\pm 25$  ppm frequency stability over temperature has a worst case frequency difference of  $\pm 45$  ppm. If the transmitter and receiver operate in different temperature environments, the resulting worst-case frequency difference may be as high as 90 ppm. Resulting drop in sensitivity due to the extra 20 ppm, is then approx. 5dB.

### **PCB layout and decoupling guidelines**

A well-designed PCB is necessary to achieve good RF performance. A PCB with a minimum of two layers including a ground plane is recommended for optimum performance.

The nRF402 DC supply voltage should be decoupled as close as possible to the VDD pins with high performance RF capacitors, see Table 8. It is preferable to mount a large surface mount capacitor (e.g. 2.2  $\mu$ F ceramic) in parallel with the smaller value capacitors. The nRF402 supply voltage should be filtered and routed separately from the supply voltages of any digital circuitry.

Long power supply lines on the PCB should be avoided. All device grounds, VDD connections and VDD bypass capacitors must be connected as close as possible to the nRF402 IC. For a PCB with a topside RF ground plane, the VSS pins should be connected directly to the ground plane. For a PCB with a bottom ground plane, the best technique is to have via holes in or close to the VSS pads.

Full swing digital data or control signals should not be routed close to the external VCO inductor or the LPF pin.

The VCO inductor placement is important. The optimum placement of the VCO inductor gives a PLL loop filter voltage of  $1.1 \pm 0.2$  V, which can be measured at LPF (pin 6). For a 22nH, 0603 size inductor the length between the centre of the



## **nRF402 Single Chip RF Transmitter**

---

VCO1/VCO2 pad and the centre of the inductor pad should be 5.4 mm, see Figure 12 (c) (layout, top view), for a 2 layer, 1.6 mm thick FR4 PCB.

### **PCB layout example**

Figure 12 shows a PCB layout example for the application schematic in Figure 11. A double-sided FR-4 board of 1.6mm thickness is used. This PCB has a continuous ground plane on the bottom layer. Additionally, there are ground areas on the component side of the board to ensure sufficient grounding of critical components. A large number of via holes connect the top layer ground areas to the bottom layer ground plane. There is no ground plane beneath the antenna.

For more layout information, please refer to application note nAN400-06, “nRF402 RF and antenna layout”.



nRF402 Single Chip RF Transmitter

APPLICATION SCHEMATIC

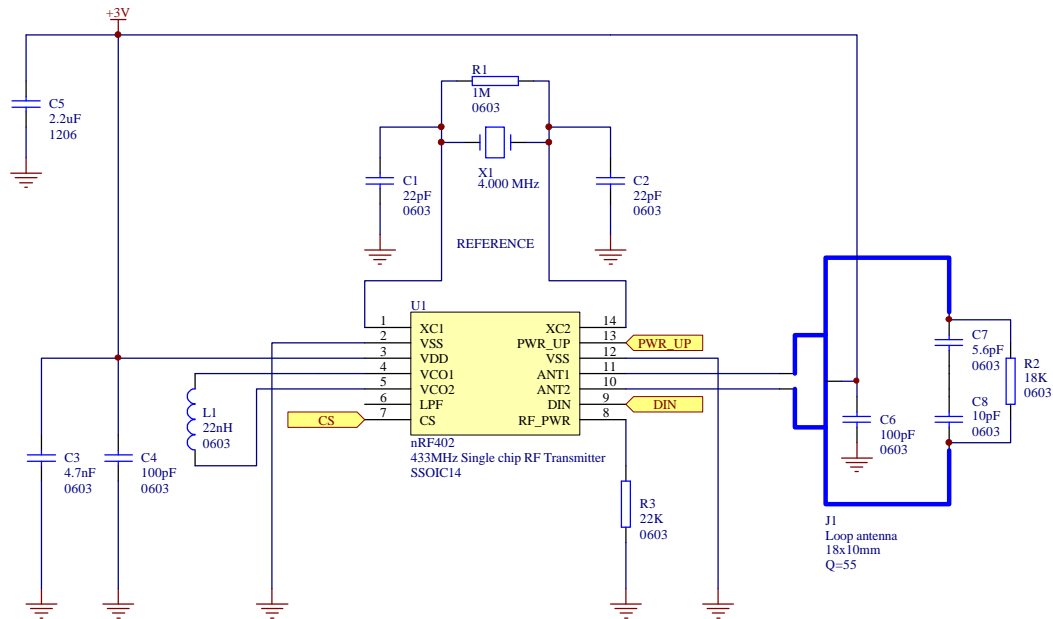
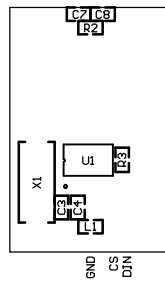

Figure 11. nRF402 application Schematic

Component	Description	Size	Value	Tolerance	Units
C1	NP0 ceramic chip capacitor, (Crystal oscillator)	0603	22		pF
C2	NP0 ceramic chip capacitor, (Crystal oscillator)	0603	22		pF
C3	X7R ceramic chip capacitor, (Supply decoupling)	0603	4.7		nF
C4	NP0 ceramic chip capacitor, (Supply decoupling)	0603	100		pF
C5	X7R ceramic chip capacitor, (Supply decoupling)	1206	2.2		μF
C6	NP0 ceramic chip capacitor, (Supply decoupling)	0603	100		pF
C7	NP0 ceramic chip capacitor, (Antenna tuning)	0603	5.6	±0.25	pF
C8	NP0 ceramic chip capacitor, (Antenna tuning)	0603	10	±0.25	pF
L1	VCO inductor, Q>45 @ 433 MHz (See table 6.)	0603	22	±2%	nH
R1	1/8W chip resistor, (Crystal oscillator)	0603	1.0		MΩ
R2	1/8W chip resistor, (Antenna Q reduction)	0603	18		kΩ
R3	1/8W chip resistor, (Transmitter power setting)	0603	22		kΩ
X1	Crystal	-	4.000		MHz

Table 8 Recommended External Components



a) Top silk screen

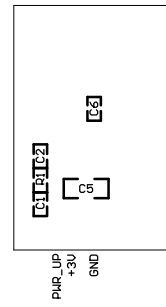

b) Bottom silk screen

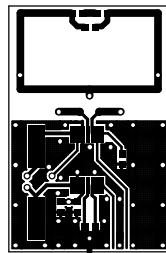

c) Top view

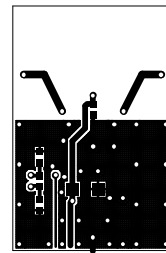

d) Bottom view

Figure 12. PCB layout (example) for nRF402 with loop antenna



**DEFINITIONS**

<b>Data sheet status</b>	
Objective product specification	This datasheet contains target specifications for product development.
Preliminary product specification	This datasheet contains preliminary data; supplementary data may be published from Nordic VLSI ASA later.
Product specification	This datasheet contains final product specifications. Nordic VLSI ASA reserves the right to make changes at any time without notice in order to improve design and supply the best possible product.
<b>Limiting values</b>	
Stress above one or more of the limiting values may cause permanent damage to the device. These are stress ratings only and operation of the device at these or at any other conditions above those given in the Specifications sections of the specification is not implied. Exposure to limiting values for extended periods may affect device reliability.	
<b>Application information</b>	
Where application information is given, it is advisory and does not form part of the specification.	

Table 9. Definitions

Nordic VLSI ASA reserves the right to make changes without further notice to the product to improve reliability, function or design. Nordic VLSI does not assume any liability arising out of the application or use of any product or circuits described herein.

**LIFE SUPPORT APPLICATIONS**

These products are not designed for use in life support appliances, devices, or systems where malfunction of these products can reasonably be expected to result in personal injury. Nordic VLSI ASA customers using or selling these products for use in such applications do so at their own risk and agree to fully indemnify Nordic VLSI ASA for any damages resulting from such improper use or sale.

Product specification: Revision Date: 29.02.2000.

Datasheet order code: 290200nRF402.

All rights reserved ®. Reproduction in whole or in part is prohibited without the prior written permission of the copyright holder.



**YOUR NOTES**



## Nordic VLSI - World Wide Distributors

For Your nearest dealer, please see <http://www.nvlsi.no>



**Main Office:**

Vestre Rosten 81, N-7075 Tiller, Norway  
Phone: +47 72 89 89 00, Fax: +47 72 89 89 89

**E-mail: [nRF@nvlsi.no](mailto:nRF@nvlsi.no)**

**Visit the Nordic VLSI ASA website at <http://www.nvlsi.no>**

---

