

120 dB, 96 kHz Audio A/D Converter

Features

- 24-Bit Conversion
- 120 dB Dynamic Range (A-Weighted)
- Low Noise and Distortion
>105 dB THD + N
- Complete CMOS Stereo A/D System
Delta-Sigma A/D Converters
Digital Anti-Alias Filtering
S/H Circuitry and Voltage Reference
- CS5396 - digital filter optimized for audio
- CS5397 - non-aliasing digital filter
- Adjustable System Sampling Rates
including 32, 44.1, 48 & 96 kHz
- Differential Analog Architecture
- Linear Phase Digital Anti-Alias Filtering
- 10 Tap Programmable Psychoacoustic
Noise Shaping Filter
- Single +5 V Power Supply

General Description

The CS5396 and CS5397 are complete analog-to-digital converters for stereo digital audio systems. They perform sampling, analog-to-digital conversion and anti-alias filtering, generating 24-bit values for both left and right inputs in serial form at sample rates up to 100 kHz per channel.

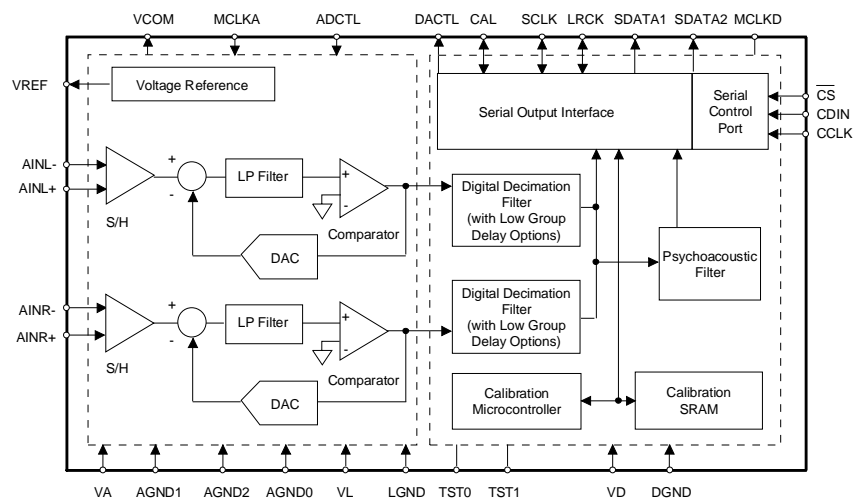
The CS5396/97 use a patented 7th-order, tri-level delta-sigma modulator followed by digital filtering and decimation, which removes the need for an external anti-alias filter. The ADCs use a differential architecture which provides excellent noise rejection.

The CS5396 has a linear phase filter optimized for audio applications with ± 0.005 dB passband ripple and >117 dB stopband rejection. The CS5397 has a non-aliasing filter response with ± 0.005 passband ripple and >117 dB stopband attenuation. Other features available in both the CS5396 and CS5397 are an optional low group delay filter and a unique psychoacoustic noise shaping filter which subjectively truncates the output to 16, 18 or 20 bits while 24-bit sound quality is preserved.

The CS5396/97 are targeted for the highest performance professional audio systems requiring wide dynamic range, negligible distortion and low noise.

ORDERING INFORMATION:

CS5396-KS	28-pin SOIC	-10 to 50°C
CS5397-KS	28-pin SOIC	-10 to 50°C
CDB5396 / 97	Evaluation Board	



Preliminary Product Information

This document contains information for a new product.
Cirrus Logic reserves the right to modify this product without notice.

TABLE OF CONTENTS

ANALOG CHARACTERISTICS	4
DIGITAL FILTER CHARACTERISTICS	5
POWER AND THERMAL CHARACTERISTICS	6
DIGITAL CHARACTERISTICS.....	6
ABSOLUTE MAXIMUM RATINGS.....	6
RECOMMENDED OPERATING CONDITIONS	7
SWITCHING CHARACTERISTICS	7
SPI CONTROL PORT SWITCHING CHARACTERISTICS.....	9
I²C CONTROL PORT SWITCHING CHARACTERISTICS	10
GENERAL DESCRIPTION	12
Stand-Alone vs. Control Port Mode	12
STAND-ALONE MODE	12
Master Clock - Stand-Alone Mode	12
Serial Data Interface - Stand-Alone Mode	12
Serial Data- Stand-Alone Mode	13
Serial Clock - Stand-Alone Mode	13
Left/Right Clock - Stand-Alone Mode	13
Master Mode - Stand-Alone Mode	13
Slave Mode - Stand-Alone Mode	13
High Pass Filter - Stand-Alone Mode	13
Power-up and Calibration - Stand-Alone Mode	13
Synchronization of Multiple Devices - Stand Alone Mode	14
CONTROL PORT MODE	14
Access to Control Port Mode	14
Internal Power-On Reset	14
Master Clock - Control Port Mode	15
64x vs. 128x Oversampling Modes	15
Serial Data Interface - Control Port Mode	15
Serial Data - Control Port Mode	15
Serial Clock - Control Port Mode	15
Left/Right Clock -Control Port Mode	15
Master Mode- Control Port Mode	17
Slave Mode - Control Port Mode	17
Synchronization of Multiple Devices - Control Port Mode	17
Power-up and Calibration - Control Port Mode	17
High Pass Filter -Control Port Mode	17
Input Level Monitoring - Control Port Mode	18
High Resolution Mode	18
Bar Graph Mode	18
Dual Digital Audio Outputs	18
Psychoacoustic Filter	19
Low Group Delay Filter	19
μC Interface Formats	19
SPI Mode	19
I ² C Mode	19
Establishing the Chip Address in I ² C Mode	19
ANALOG CONNECTIONS - ALL MODES	20
GROUNDING AND POWER SUPPLY DECOUPLING - ALL MODES	20
DIGITAL FILTER PLOTS	21
REGISTER DESCRIPTION	24
PIN DESCRIPTIONS	30

Power Supply Connections	30
Analog Inputs	30
Analog Outputs.....	31
Digital Inputs.....	31
Digital Input Pin Definitions for Stand-Alone MODE.....	31
Digital Pin Definitions for CONTROL-PORT MODE.....	32
Digital Outputs.....	32
Digital Inputs or Outputs.....	33
Miscellaneous.....	33
PARAMETER DEFINITIONS.....	34
ADDITIONAL INFORMATION.....	35
PACKAGE DIMENSIONS	36
APPENDIX A: 64X VS. 128X OVERSAMPLING MODES	37
APPENDIX B: EXTERNAL DATA INPUT TO DIGITAL FILTER.....	37
APPENDIX C: PSYCHOACOUSTIC FILTER	37

ANALOG CHARACTERISTICS ($T_A = 25^\circ\text{C}$; $V_A, V_L, V_D = 5\text{V}$; Full-scale Input Sinewave, 997 Hz; Analog connections as shown in Figure 1; Measurement Bandwidth is 20 Hz to 20 kHz unless otherwise specified; Logic 0 = 0V, Logic 1 = V_D ;

Parameter	Symbol	Min	Typ	Max	Units	
Dynamic Performance						
Dynamic Range	MCLK equal to 24.576 MHz					
Fs = 48 kHz in 128x Oversampling Mode	(A-weighted)	TBD	120	-	dB	
Fs = 48 kHz in 128x mode		TBD	117	-	dB	
Fs = 96 kHz in 64x mode	(A-weighted)	TBD	120	-	dB	
Fs = 96 kHz in 64x mode	(40 kHz Bandwidth)	TBD	114	-	dB	
Fs = 48 kHz in 64x mode	MCLK equal to 12.288 MHz	TBD	117	-	dB	
Fs = 48 kHz in 64x mode	(A-weighted)	TBD	114	-	dB	
Total Harmonic Distortion + Noise		THD+N				
Fs = 48 kHz in 128x mode	-1 dB (Note 1)	TBD	105	-	dB	
	-20 dB (Note 1)	TBD	97	-	dB	
	-60 dB (Note 1)	TBD	57	-	dB	
Fs = 96 kHz in 64x mode	-1 dB (Note 1)	TBD	105	-	dB	
(40 kHz bandwidth)	-20 dB (Note 1)	TBD	97	-	dB	
	-60 dB (Note 1)	TBD	57	-	dB	
Fs = 48 kHz in 64x mode	-1 dB (Note 1)	TBD	105	-	dB	
	-20 dB (Note 1)	TBD	97	-	dB	
	-60 dB (Note 1)	TBD	57	-	dB	
Total Harmonic Distortion	-1 dB (Note 1)	THD	TBD	0.00056	%	
Interchannel Phase Deviation		-	0.0001	-	deg	
Interchannel Isolation		-	120	-	dB	
Dynamic Range Performance Drift	(following calibration)	-	0.05	-	dB/ $^\circ\text{C}$	
dc Accuracy						
Interchannel Gain Mismatch		-	0.05	-	dB	
Gain Error		-	± 5	TBD	%	
Gain Drift		-	± 100	-	ppm/ $^\circ\text{C}$	
Offset Error (With high pass filter enabled)		-	0	-	LSB	
Analog Input						
Full-scale Differential Input Voltage	(Note 2)	V_{IN}	TBD	4	TBD	V_{pp}
Input Impedance	Differential	Z_{IN}	-	4.5	-	k Ω
	Common-mode		-	TBD	-	k Ω
Common-Mode Rejection Ratio		CMRR	-	82	-	dB

- Notes: 1. Referenced to typical full-scale differential input voltage (4.0 V_{pp}).
 2. Specified for a fully differential input $\pm\{(AINR+)-(AINR-)\}$. The ADC accepts input voltages up to the analog supplies (V_A and AGND). Full-scale outputs will be produced for differential inputs beyond V_{IN} .

* Refer to Parameter Definitions at the end of this data sheet.
 Specifications are subject to change without notice.

DIGITAL FILTER CHARACTERISTICS ($T_A = 25\text{ }^\circ\text{C}$; $V_A, V_L, V_D = 5V \pm 5\%$; $F_s = 48\text{ kHz}$)

Parameter	Symbol	CS5396			CS5397			Unit
		Min	Typ	Max	Min	Typ	Max	
High-Performance Filter								
Passband (-0.01 dB)		0	-	0.4604	0	-	0.3958	Fs
Passband Ripple		-	-	± 0.005	-	-	± 0.005	dB
Stopband		0.5542	-	63.45	0.4979	-	63.50	Fs
Stopband Attenuation		117	-	-	117	-	-	dB
Group Delay ($F_s =$ Output Sample Rate)								
128x Oversampling Mode	t_{gd}	-	34/ F_s	-	-	34/ F_s	-	μs
64x Oversampling Mode		-	34/ F_s	-	-	34/ F_s	-	μs
Group Delay Variation vs. Frequency	Δt_{gd}	-	-	0.0	-	-	0.0	μs
Low Group Delay Filter								
Passband (-0.01 dB)								
128x Oversampling Mode		0	-	0.375	0	-	0.375	Fs
64x Oversampling Mode		0	-	0.188	0	-	0.188	Fs
Passband Ripple		-	-	0.015	-	-	0.015	dB
Stopband								
128x Oversampling Mode		0.646	-	127.35	0.646	-	127.35	Fs
64x Oversampling Mode		0.323	-	63.68	0.323	-	63.68	Fs
Stopband Attenuation		86	-	-	86	-	-	dB
Group Delay ($F_s =$ Output Sample Rate)	t_{gd}	-	10/ F_s	-	-	10/ F_s	-	μs
Group Delay Variation vs. Frequency	Δt_{gd}	-	-	0.0	-	-	0.0	μs
High Pass Filter Characteristics								
Frequency Response -3.0 dB (Note 3)		-	1.8	-	-	1.8	-	Hz
-0.036 dB (Note 3)			20	-		20	-	Hz
Phase Deviation @ 20Hz (Note 3)		-	5.3	-	-	5.3	-	Deg
Passband Ripple		-	-	0	-	-	0	dB

Notes: 3. Response shown is for F_s equal to 48 kHz. Filter characteristics scale with F_s .

POWER AND THERMAL CHARACTERISTICS

($T_A = 25\text{ }^\circ\text{C}$; $V_A, V_L, V_D = 5V \pm 5\%$; $F_s = 48\text{ kHz}$; Master Mode)

Parameter	Symbol	64X oversampling MCLK=12.288 MHz			128X oversampling MCLK=24.576 MHz			Unit	
		Min	Typ	Max	Min	Typ	Max		
Power Supply Current (Normal Operation)	V_A+V_L	I_A	-	150	TBD	-	160	TBD	mA
	V_D	I_D	-	65	TBD	-	125	TBD	mA
Power Supply Current (Power-Down Mode)	V_A+V_L	I_A	-	2	-	-	3	-	mA
	V_D	I_D	-	2	-	-	3.5	-	mA
Power Consumption (Normal Operation) (Power-Down Mode)			-	1075	TBD	-	1425	TBD	mW
			-	20	-	-	33	-	mW
Power Supply Rejection Ratio (1 kHz)	PSRR	-	65	-	-	65	-	dB	
Allowable Junction Temperature		-	-	135	-	-	135	$^\circ\text{C}$	
Junction to Ambient Thermal Impedance	T_{JA}	-	45	-	-	45	-	$^\circ\text{C/W}$	

DIGITAL CHARACTERISTICS ($T_A = 25\text{ }^\circ\text{C}$; $V_A, V_L, V_D = 5V \pm 5\%$)

Parameter	Symbol	Min	Typ	Max	Units
High-Level Input Voltage	V_{IH}	2.4	-	-	V
Low-Level Input Voltage	V_{IL}	-	-	0.8	V
High-Level Output Voltage at $I_o = -20\text{ }\mu\text{A}$	V_{OH}	$V_D - 1.0$	-	-	V
Low-Level Output Voltage at $I_o = 20\text{ }\mu\text{A}$	V_{OL}	-	-	0.4	V
Input Leakage Current	I_{in}	-	-	± 10	μA

ABSOLUTE MAXIMUM RATINGS (AGND, DGND = 0V, All voltages with respect to ground.)

Parameter	Symbol	Min	Typ	Max	Units	
DC Power Supplies:	Analog	V_A	-0.3	-	+6.0	V
	Logic	V_L	-0.3	-	+6.0	V
	Digital	V_D	-0.3	-	+6.0	V
	$ V_A - V_D $	(Note 6)	-	-	0.4	V
	$ V_A - V_L $	(Note 6)	-	-	0.4	V
	$ V_D - V_L $	(Note 6)	-	-	0.4	V
Input Current	(Note 4) I_{in}	-	-	± 10	mA	
Analog Input Voltage	(Note 5) V_{IN}	AGND-0.7	-	$V_A+0.7$	V	
Digital Input Voltage	(Note 5) V_{IND}	-0.3	-	$V_D+0.7$	V	
Ambient Operating Temperature (Power Applied)	T_A	-55	-	+50	$^\circ\text{C}$	
Storage Temperature	T_{stg}	-65	-	+150	$^\circ\text{C}$	

Notes: 4. Any pin except supplies. Transient currents of up to $\pm 100\text{ mA}$ on the analog input pins will not cause SCR latch-up.

5. The maximum over/under voltage is limited by the input current.

6. Applies to normal operation. Greater differences during power up/down will not cause SCR latch-up.
WARNING: Operation beyond these limits may result in permanent damage to the device.

Normal operation is not guaranteed at these extremes.

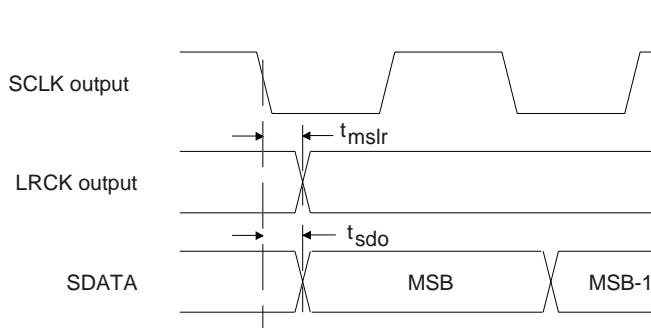
RECOMMENDED OPERATING CONDITIONS (AGND, DGND = 0V, all voltages with respect to ground.)

Parameter	Symbol	Min	Typ	Max	Units	
DC Power Supplies:	Positive Digital	VD	4.75	5.0	5.25	V
	Positive Logic	VL	4.75	5.0	5.25	V
	Positive Analog	VA	4.75	5.0	5.25	V
	VA - VD (Note 6)	-	-	0.4	V	
Ambient Operating Temperature (Power Applied)	T _A	-10	-	+50	°C	

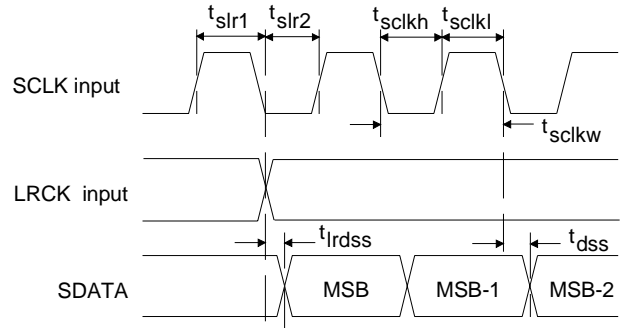
Specifications are subject to change without notice.

SWITCHING CHARACTERISTICS (T_A = 25 °C; VA = 5V±5%; Inputs: Logic 0 = 0V, Logic 1 = VA = VD; C_L = 20 pF)

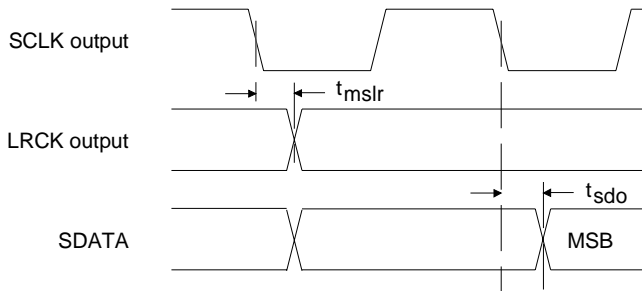
Parameter	Symbol	Min	Typ	Max	Units
Output Sample Rate	F _s	2	-	100	kHz
MCLK Period	t _{clkw}	39.06	-	1950	ns
MCLK Low	t _{ckl}	26	-	-	ns
MCLK High	t _{clkh}	26	-	-	ns
MCLK Fall Time	t _{clkft}	-	-	8	ns
Master Mode					
SCLK falling to LRCK	t _{mslr}	-20	-	+20	ns
SCLK falling to SDATA valid	t _{sdo}	-	-	20	ns
SCLK duty cycle		-	50	-	%
Slave Mode					
LRCK Period	1/F _s	10	-	500	µs
LRCK duty cycle		-	50	-	%
SCLK Period	t _{sclkw}	4 x t _{clw}	-	-	ns
SCLK Pulse Width Low	t _{sckl}	2 x t _{clw}	-	-	ns
SCLK Pulse Width High	t _{clkh}	60	-	-	ns
SCLK falling to SDATA valid	t _{dss}	-	-	t _{clw} + 20 ns	ns
LRCK edge to MSB valid	t _{irdss}	-	-	t _{clw} + 20 ns	ns
SCLK rising to LRCK edge delay	t _{slr1}	t _{clw} + 20 ns	-	-	ns
LRCK edge to rising SCLK setup time	t _{slr2}	t _{clw} + 20 ns	-	-	ns



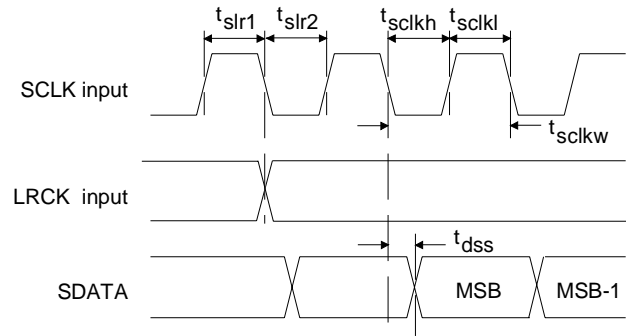
SCLK to SDATA & LRCK - MASTER mode
Serial Data Format, Left Justified



SCLK to LRCK & SDATA - SLAVE mode
Serial Data Format, Left Justified



SCLK to SDATA & LRCK - MASTER mode
Serial Data Format, I²S compatible



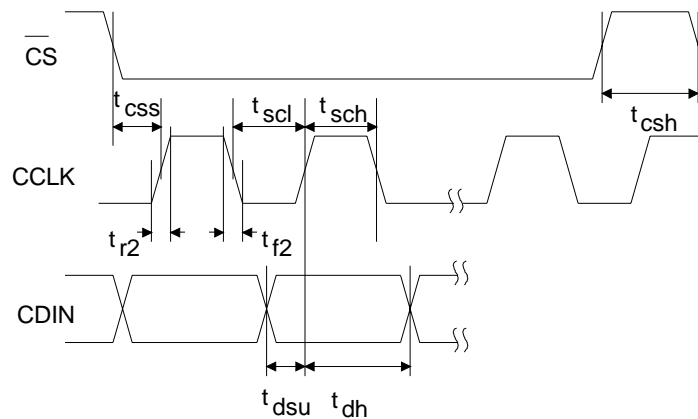
SCLK to LRCK & SDATA - SLAVE mode
Serial Data Format, I²S compatible

SPI CONTROL PORT SWITCHING CHARACTERISTICS ($T_A = 25\text{ }^\circ\text{C}$; $V_D, V_A = 5V \pm 5\%$;
 Inputs: Logic 0 = DGND, Logic 1 = V_D ; $C_L = 20\text{ pF}$)

Parameter	Symbol	Min	Max	Unit
SPI Mode				
CCLK Clock Frequency	f_{sck}	-	6	MHz
\overline{CS} High Time Between Transmissions	t_{csh}	1.0	-	μs
\overline{CS} Falling to CCLK Edge	t_{css}	20	-	ns
CCLK Low Time	t_{scl}	66	-	ns
CCLK High Time	t_{sch}	66	-	ns
CDIN to CCLK Rising Setup Time	t_{dsu}	40	-	ns
CCLK Rising to DATA Hold Time (Note 7)	t_{dh}	15	-	ns
Rise Time of CCLK and CDIN (Note 8)	t_{r2}	-	100	ns
Fall Time of CCLK and CDIN (Note 8)	t_{f2}	-	100	ns

Notes: 7. Data must be held for sufficient time to bridge the transition time of CCLK.

8. For $F_{SCK} < 1\text{ MHz}$.

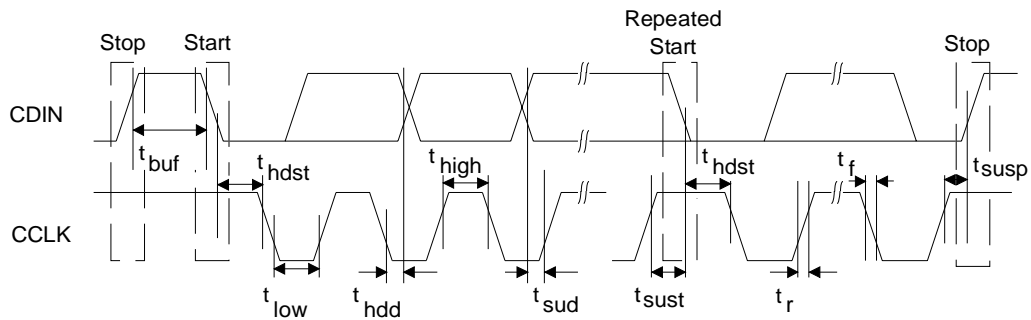


I²C CONTROL PORT SWITCHING CHARACTERISTICS (T_A = 25 °C; V_D, V_A = 5V ±5%; Inputs: Logic 0 = DGND, Logic 1 = V_D; C_L = 20 pF)

Parameter	Symbol	Min	Max	Unit
I²C[®] Mode (Note 9)				
CCLK Clock Frequency	f _{scl}	-	100	kHz
Bus Free Time Between Transmissions	t _{buf}	4.7	-	μs
Start Condition Hold Time (prior to first clock pulse)	t _{hdst}	4.0	-	μs
Clock Low Time	t _{low}	4.7	-	μs
Clock High Time	t _{high}	4.0	-	μs
Setup Time for Repeated Start Condition	t _{sust}	4.7	-	μs
CDIN Hold Time from CCLK Falling (Note 10)	t _{hdd}	0	-	μs
CDIN Setup Time to CCLK Rising	t _{sud}	250	-	ns
Rise Time of Both CDIN and CCLK Lines	t _r	-	1	μs
Fall Time of Both CDIN and CCLK Lines	t _f	-	300	ns
Setup Time for Stop Condition	t _{susp}	4.7	-	μs

Notes: 9. Use of the I²C[®] bus interface requires a license from Philips.

10. Data must be held for sufficient time to bridge the 300 ns transition time of SCL.



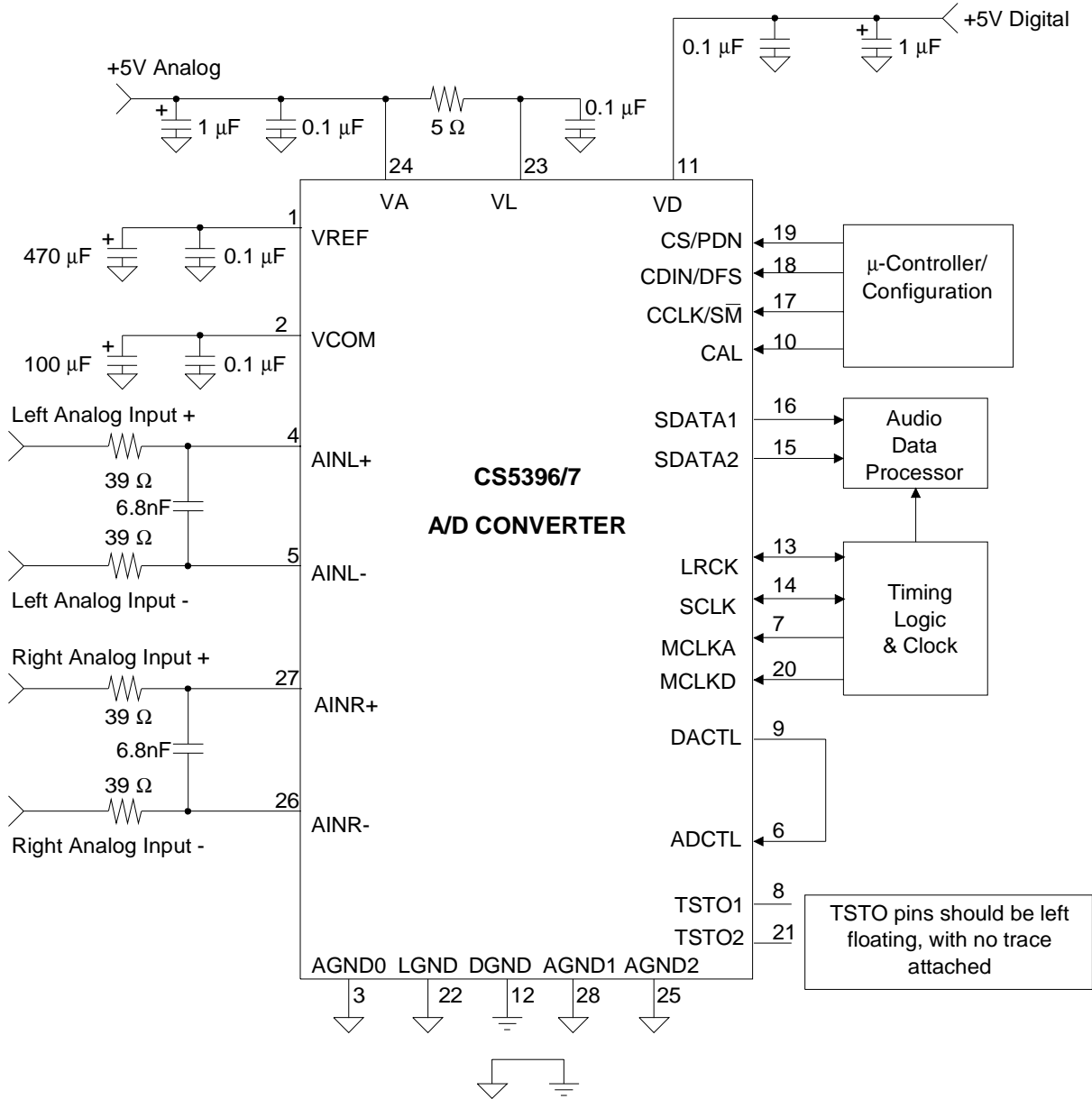


Figure 1. Typical Connection Diagram

GENERAL DESCRIPTION

The CS5396/97 is a 24-bit, stereo A/D converter designed for stereo digital audio applications. The analog input channels are simultaneously sampled by separate, patented, 7th-order tri-level delta-sigma modulators at either 128 or 64 times the output sample rate ($64 \times F_s$ or $128 \times F_s$) of the device. The resulting serial bit streams are digitally filtered, yielding pairs of 24-bit values at output sample rates (F_s) of up to 100 kHz. This technique yields nearly ideal conversion performance independent of input frequency and amplitude. The converter does not require difficult-to-design or expensive anti-alias filters, and it does not require external sample-and-hold amplifiers or voltage references. Only normal power supply decoupling components, voltage reference bypass capacitors and a single resistor and capacitor on each input for anti-aliasing are required, as shown in Figure 1. An on-chip voltage reference provides for a differential input signal range of 4.0 Vpp. The device also contains a high pass filter, implemented digitally after the decimation filter, to completely eliminate any internal offsets in the converter or any offsets present at the input circuitry to the device. Output data is available in serial form, coded as 2's complement 24-bit numbers. For more information on delta-sigma modulation techniques see the references at the end of this data sheet.

Stand-Alone vs. Control Port Mode

The CS5396/97 can operate in either Stand-Alone or Control Port Mode. The functionality of pins 17, 18 and 19 is established upon entering either the Stand-Alone or Control Port mode, as described in the Pin Description section.

The Control Port Mode requires a micro-controller and allows access to many additional features, which include:

- 128× Oversampling Mode
- Reduction of 24-bit data to 20, 18 or 16-bit data with psychoacoustically optimized dither
- Programmability of psychoacoustic filter coefficients
- Peak Input Signal Level Monitor with either High Resolution or Bar Graph mode selection
- Signal inversion
- High pass filter defeat
- Mute
- Access to the digital filter to allow the input of external digital audio data to produce a two-to-one decimated output and/or psychoacoustic bit reduction.

STAND-ALONE MODE

Master Clock - Stand-Alone Mode

The master clock is the clock source for the delta-sigma modulator sampling (MCLKA) and digital filters (MCLKD). The required MCLKA/D frequency is determined by the desired F_s and must be $256 \times F_s$. Table 1 shows some common master clock frequencies.

LRCK (kHz)	MCLKA/D (MHz)	SCLK (MHz)
32	8.192	2.048
44.1	11.2896	2.822
48	12.288	3.072
64	16.384	4.096
88.2	22.5792	5.6448
96	24.576	6.144

Table 1. Common Clock Frequencies for Stand-Alone Mode

Serial Data Interface - Stand-Alone Mode

The CS5396/97 supports two serial data formats which are selected via the digital format select pin, DFS. The digital output format determines the relationship between the serial data, left/right clock and serial clock. Figures 2 and 3 detail the interface formats. The serial data interface is accomplished via

the serial data outputs; SDATA1 and SDATA2; serial data clock, SCLK, and the left/right clock, LRCK. The serial nature of the output data results in the left and right data words being read at different times. However, the samples within an LRCK cycle represent simultaneously sampled analog inputs.

Serial Data- Stand-Alone Mode

The serial data block consists of 24 bits of audio data presented in 2's-complement format with the MSB-first. The data is clocked from SDATA1 and SDATA2 by the serial clock and the channel is determined by the Left/Right clock. The full precision 24-bit data is available on SDATA1 and the output from the low group delay filter is available on SDATA2.

Serial Clock - Stand-Alone Mode

The serial clock shifts the digitized audio data from the internal data registers via the SDATA1 and SDATA2 pins. SCLK is an output in Master Mode where internal dividers will divide the master clock by 4 to generate a serial clock which is $64 \times F_s$. In Slave Mode, SCLK is an input with a serial clock typically between $48 \times$ and $128 \times F_s$. However, it is recommended that SCLK be equal to $64 \times$, though other frequencies are possible, to avoid potential interference effects which may degrade system performance.

Left/Right Clock - Stand-Alone Mode

The Left/Right clock, LRCK, determines which channel, left or right, is to be output on SDATA1 and SDATA2. In Master Mode, LRCK is an output whose frequency is equal to F_s . In Slave Mode, LRCK is an input whose frequency must be equal to F_s and synchronous to MCLKA/D.

Master Mode - Stand-Alone Mode

In Master mode, SCLK and LRCK are outputs which are internally derived from the master clock. Internal dividers will divide MCLKA/D by 4 to

generate a SCLK which is $64 \times F_s$ and by 256 to generate a LRCK which is equal to F_s . The CS5396/97 is placed in the Master mode with the slave/master pin, S/\overline{M} , low.

Slave Mode - Stand-Alone Mode

LRCK and SCLK become inputs in SLAVE mode. LRCK must be externally derived from MCLKA/D and be equal to F_s . It is recommended that SCLK be equal to $64 \times$. Other frequencies between $48 \times$ and $128 \times F_s$ are possible but may degrade system performance due to interference effects. The master clock frequency must be $256 \times F_s$. The CS5396/97 is placed in the Slave mode with the slave/master pin, S/\overline{M} , high.

High Pass Filter - Stand-Alone Mode

The CS5396/97 includes a high pass filter after the decimator to remove the DC offsets introduced by the analog buffer stage and the CS5396/97 analog modulator. The characteristics of this first-order high pass filter are outlined below, for F_s equal to 48 kHz. This filter response scales linearly with sample rate.

Frequency response: -3 dB @ 1.8 Hz
-0.036 dB @ 20 Hz
Phase deviation: 5.3 degrees @ 20 Hz
Passband ripple: None

Power-up and Calibration - Stand-Alone Mode

The delta-sigma modulators settle in a matter of microseconds after the analog section is powered, either through the application of power or by exiting the power-down mode. However, the voltage reference will take a much longer time to reach a final value due to the presence of external capacitance on the VREF pin. A time delay of approximately $10\text{ms}/\mu\text{F}$ is required after applying power to the device or after exiting a power down state.

A calibration of the tri-level delta-sigma modulator should always be initiated following power-up and after allowing sufficient time for the voltage on the external VREF capacitor to settle. This is required to minimize noise and distortion. It is also advised that the CS5396/97 be calibrated after the device has reached thermal equilibrium, approximately 10 seconds, to maximize performance.

Synchronization of Multiple Devices - Stand Alone Mode

In systems where multiple ADCs are required, care must be taken to achieve simultaneous sampling. It is recommended that the rising edge of the CAL signal be timed with a falling edge of MCLK to ensure that all devices will initiate a calibration and synchronization sequence on the same rising edge of MCLK. The absence of re-timing of the CAL signal can result in a sampling difference of one MCLK period.

CONTROL PORT MODE

Access to Control Port Mode

The mode selection between Stand-Alone and Control Port Mode is determined by the state of the SDATA1 pin 250 MCLK cycles following the internal power-on reset. A 47 kΩ pull-up resistor on SDATA1 will select the Control Port Mode. However, the control port will not respond to CCLK and CDIN until the pull-up on the SDATA1 pin is released.

Internal Power-On Reset

The timing required to determine Control port mode and I²S/SPI mode is based on an internal power-on reset. The internal power-on reset requires the power supply to exceed a threshold voltage. However, there is no external indication of when the internal reset is activated. If precise timing of the Control port and I²S/SPI decisions is required, MCLK should not be applied until the power supply has stabilized.

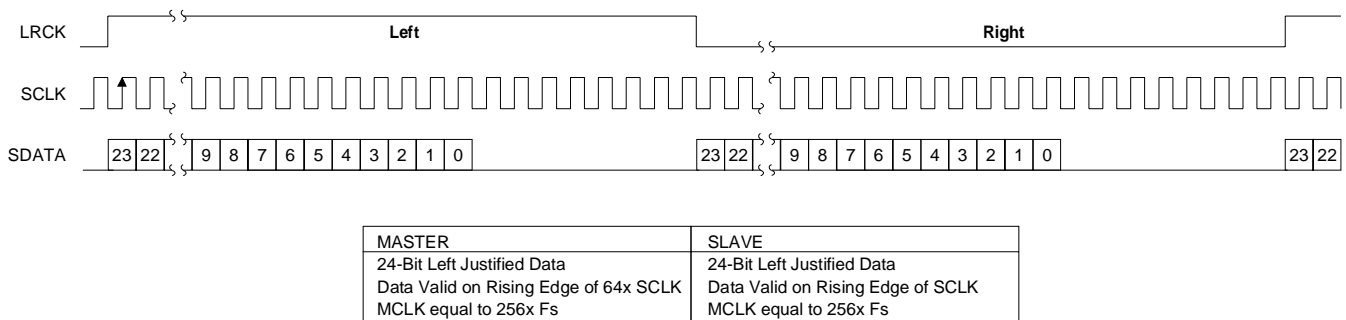


Figure 2. Serial Data Format 0, Stand-Alone Mode, DFS low. Left Justified.

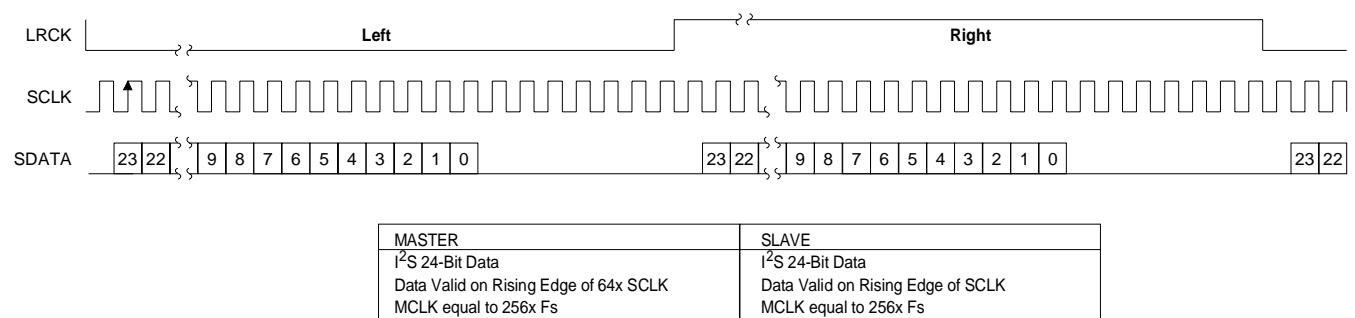


Figure 3. Serial Data Format 1, Stand-Alone Mode, DFS High. I²S compatible

Master Clock - Control Port Mode

The master clock is the clock source for the delta-sigma modulator sampling (MCLKA) and digital filters (MCLKD). The required MCLKA/D frequency is determined by the desired Fs and the chosen Oversampling Mode. Table 2 shows some common master clock frequencies.

64× vs. 128× Oversampling Modes

The CS5396/97 can operate in a 64× Oversampling Mode with a 256× master clock (MCLKA/D) at a maximum sample rate of 100 kHz. The device can also operate in a 128× Oversampling Mode with a 512× master clock (MCLKA/D) where the maximum Fs is 50 kHz. Notice that the required master clock is 24.576 MHz for Fs equal to either 48 kHz in the 128× Oversampling Mode or 96 kHz in the 64× Oversampling Mode. The sampling mode is set via the control register which alters the decimation ratio of the digital filter. The 64× Oversampling Mode is the default mode. Table 2 shows some common clock frequencies for both modes. Refer to Appendix A for additional discussion of 64× vs. 128× Oversampling Modes.

LRCK (kHz)	Over-sampling	MCLKA/D (MHz)	SCLK (MHz)
32	64	8.192	2.048
44.1	64	11.2896	2.822
48	64	12.288	3.072
32	128	16.384	4.096
44.1	128	22.5792	5.6448
48	128	24.576	6.144
64	64	16.384	4.096
88.2	64	22.5792	5.6448
96	64	24.576	6.144

Table 2. Common Clock Frequencies

Serial Data Interface - Control Port Mode

The CS5396/97 supports two serial data formats which are selected via the control register. The digital output format determines the relationship between the serial data, left/right clock and serial

clock. Figures 4 - 7 detail the interface formats. The serial data interface is accomplished via the serial data outputs; SDATA1 and SDATA2, serial data clock, SCLK, and the left/right clock, LRCK. The serial nature of the output data results in the left and right data words being read at different times. However, the samples within an LRCK cycle represent simultaneously sampled analog inputs.

Serial Data - Control Port Mode

The serial data block is presented in 2's-complement format with the MSB-first. The data is clocked from SDATA1 and SDATA2 by the serial clock and the channel is determined by the Left/Right clock. The full precision 24 bit data is available on SDATA1 and the output from the low group delay is available on SDATA2.

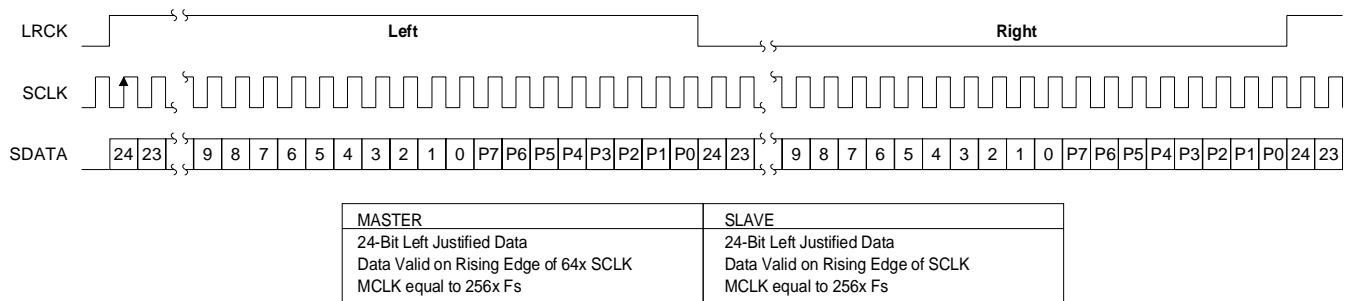
The serial data can be followed by 8 Peak Signal Level, PSL, bits as shown in Figures 4 - 7 if the PKEN bit is set. Refer to the Dual Audio Output section of this data sheet for further discussion of SDATA1 and SDATA2 options.

Serial Clock - Control Port Mode

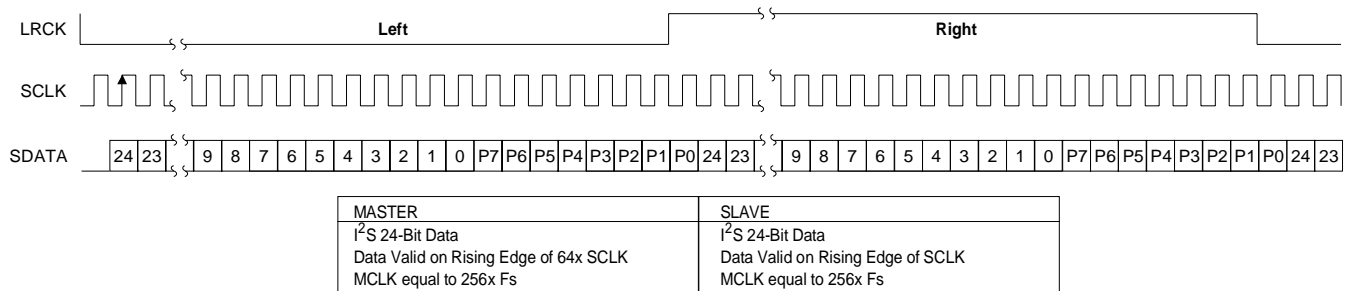
The serial clock shifts the digitized audio data from the internal data registers via SDATA1 and SDATA2. SCLK is an output in Master Mode where internal dividers will divide the master clock by 4 to generate a serial clock which is 64× Fs in the 64× Oversampling Mode. In the 128× Oversampling Mode, internal dividers will divide MCLKA/D by 4 to generate a SCLK which is 128× Fs. In Slave Mode, SCLK is an input with a serial clock typically between 48× and 128× Fs. It is recommended that SCLK be equal to 64× in the 64× Oversampling Mode and equal to 128× in the 128× Oversampling Mode to avoid possible system performance degradation due to interference effects.

Left/Right Clock -Control Port Mode

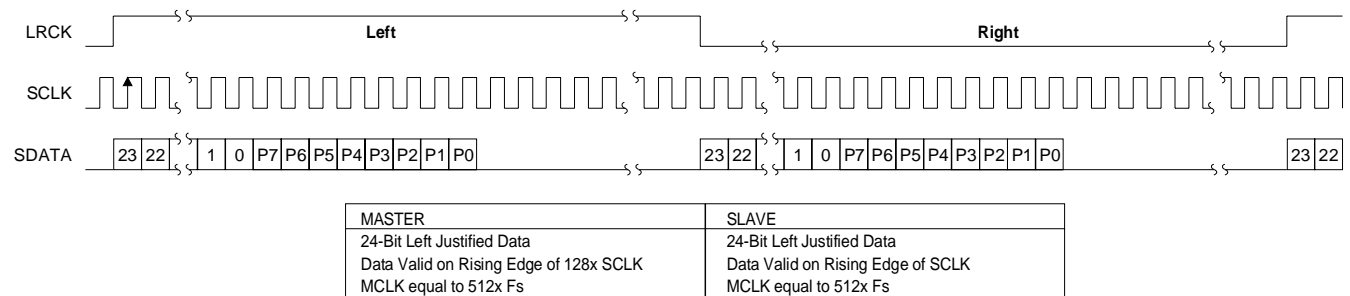
The Left/Right clock, LRCK, determines which channel, left or right, is to be output on SDATA1


Figure 4. Control Port Mode, Serial Data. Left Justified. 64x Oversampling Mode

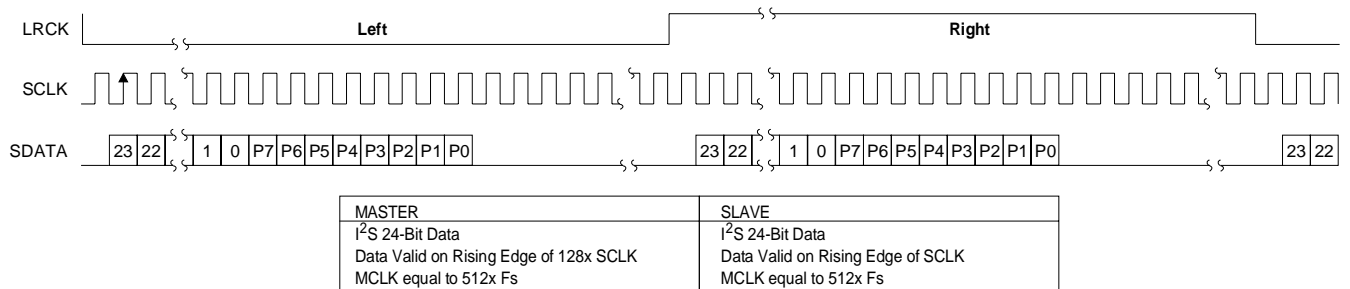
The peak signal level bits are available only if Bit 6 of Byte 7 is set.


Figure 5. Control Port Mode, Serial Data. I²S Compatible. 64x Oversampling Mode.

The peak signal level bits are available only if Bit 6 of Byte 7 is set.


Figure 6. Control Port Mode, Serial Data. Left Justified. 128x Oversampling Mode

The peak signal level bits are available only if Bit 6 of Byte 7 is set.


Figure 7. Control Port Mode, Serial Data. I²S Compatible. 128x Oversampling Mode.

The peak signal level bits are available only if Bit 6 of Byte 7 is set.

and SDATA2. In Master Mode, LRCK is an output whose frequency is equal to F_s . In Slave Mode, LRCK is an input whose frequency must be equal to F_s and synchronous to MCLKA/D.

Master Mode- Control Port Mode

In Master mode, SCLK and LRCK are outputs which are internally derived from the master clock. In the 64× Oversampling Mode, internal dividers will divide MCLKA/D by 4 to generate a SCLK which is 64× F_s and by 256 to generate a LRCK which is equal to F_s . In the 128× Oversampling Mode, internal dividers will divide MCLKA/D by 4 to generate a SCLK which is 128× F_s and by 512 to generate a LRCK which is equal to F_s . The CS5396/97 is placed in the Master mode via the control register.

Slave Mode - Control Port Mode

LRCK and SCLK become inputs in SLAVE mode. LRCK must be externally derived from MCLKA/D and be equal to F_s . It is recommended that SCLK be equal to 64× in the 64× Oversampling Mode and equal to 128× in the 128× Oversampling Mode. Other frequencies are possible but may degrade system performance due to interference effects. The CS5396/97 is placed in the Slave mode via the control register.

Synchronization of Multiple Devices - Control Port Mode

In systems where multiple ADCs are required, care must be taken to achieve simultaneous sampling. The FSTART bit in register 1 controls the synchronization of the internal clocks and sampling process between the analog modulator and the digital filter. Multiple ADCs can be synchronized if the FSTART command is initiated on the same edge of MCLK. This can be accomplished by re-timing the CCLK clock with the falling edge of MCLK. This is a relatively simple matter if the ADCs have the same address. However, if the system requires the

devices to have individual addresses, synchronization can be accomplished by;

- 1) Disable the address enable bit (ADDREN) in register 7
- 2) Issue a system broadcast FSTART command synchronized with CCLK.
- 3) Reset the ADDREN bit.

Power-up and Calibration - Control Port Mode

The delta-sigma modulators settle in a matter of microseconds after the analog section is powered, either through the application of power or by exiting the power-down mode. However, the voltage reference will take a much longer time to reach a final value due to the presence of external capacitance on the VREF pin. A time delay of approximately 10ms/μF is required after applying power to the device or after exiting a power down state.

A calibration of the tri-level delta-sigma modulator should always be initiated following power-up and after allowing sufficient time for the voltage on the external VREF capacitor to settle. This is required to minimize noise and distortion. It is also advised that the CS5396/97 be calibrated after the device has reached thermal equilibrium to maximize performance. A calibration sequence requires the following commands;

- 1) set the FSTART bit
- 2) set the GND CAL bit
- 3) set the CAL bit
- 4) Wait a minimum of 2050 LRCK periods in the 128x mode or 4100 LRCK periods in the 64x mode.
- 5) Remove GND CAL

High Pass Filter -Control Port Mode

The CS5396/97 includes a high pass filter after the decimator to remove the DC offsets introduced by

put formats include: inverted output, psychoacoustic output (16-bit, 18-bit, 20-bit), and low group delay output.

Psychoacoustic Filter

The CS5396/97 includes a programmable 10 tap digital filter which can be used to perform psychoacoustic noise-shaping of the audio spectrum if desired. The filter can implement a variety of 16-bit, 18-bit, or 20-bit noise-shaped responses by setting the digital filter coefficients. Further discussion of the psychoacoustic filter can be found in Appendix C.

Appendix B discusses an application using the psychoacoustic filter independently of the A/D converter function. In this mode, SDATA2 becomes an input to the psychoacoustic filter stage and SDATA1 is the digital audio output.

Low Group Delay Filter

The characteristics of the low group delay filter are shown in Figures 17 - 24.

μC Interface Formats

The device supports either SPI or I²C interface formats. The CS5396/97 monitors the state of \overline{CS} during power-up and will configure to an SPI interface if the pin is held low. Conversely, if the pin is held high, the port will configure to a I²C interface.

SPI Mode

In SPI mode, \overline{CS} is the chip select signal, CCLK is the μC bit clock and CDIN is the input data line from the microcontroller. Notice that it is not possible to read the CS5396/97 registers in SPI mode due to the lack of a data output pin.

To write to a register, bring \overline{CS} low. The first 7 bits on CDIN are the chip address, and must be zero. The eighth bit is a read/write indicator (R/ \overline{W}) which must be low.

The next 8 bits form the Memory Address Pointer (MAP), which is set to the address of the register

that is to be updated. The next 8 bits are the data which will be placed into the register designated by the MAP.

The CS5396/97 has a MAP auto increment, which will increment the MAP after each byte is written, allowing block writes of successive registers.

I²C Mode

In I²C mode, CDIN is a bidirectional data line. Data is clocked into and out of the part by CCLK.

The eighth bit of the address byte is the R/ \overline{W} bit (high for a read, low for a write). If the operation is a write, the next byte is the Memory Address Pointer which selects the register to be read or written. If the operation is a read, the contents of the register pointed to by the Memory Address Pointer will be output. MAP allows successive reads or writes of consecutive registers. Each byte is separated by an acknowledge bit. Use of the I²C bus compatible interface requires a license from Philips. I²C bus is a registered trademark of Philips Semiconductors.

Establishing the Chip Address in I²C Mode

Connecting SDATA1 pin and \overline{CS} to 5 volts during power-up will set the device to the Control Port and I²C mode. However, the control port will not respond to CCLK and CDATA until the hold on the SDATA1 pin is released. The chip address can be set by:

- 1) Release the hold on the SDATA1 pin of the device to be addressed.
- 2) Program the chip address and set the Address Enable bit, *addren*, which will prevent further communication to this device without the correct address.
- 3) Repeat steps 1 and 2 for the remaining devices on the bus.

ANALOG CONNECTIONS - ALL MODES

Figure 1 shows the analog input connections. The analog inputs are presented differentially to the

modulators via the AINR+/- and AINL+/- pins. Each analog input will accept a maximum of 2.0 Vpp. The + and - input signals are 180° out of phase resulting in a differential input voltage of 4.0 Vpp. Figure 8 shows the input signal levels for full scale.

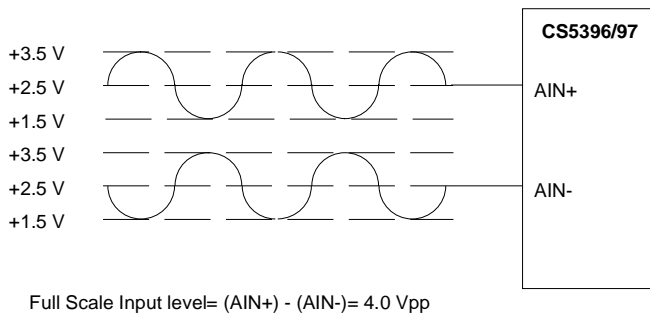


Figure 8. Full scale input voltage

The analog modulator samples the input at 6.144 MHz (MCLK=24.576 MHz) corresponding to Fs equal to 48 kHz in the 128× Oversampling Mode and Fs equal to 96 kHz in the 64× Oversampling Mode. The digital filter will reject signals within the stopband of the filter. However, there is no rejection for input signals which are $(n \times 6.144 \text{ MHz}) \pm$ the digital passband frequency, where $n=0,1,2,\dots$. A 39 Ω resistor in series with the analog input and a 6.8 nF COG capacitor between the inputs will attenuate any noise energy at 6.144 MHz, in addition to providing the optimum source impedance for the modulators. The use of capacitors which have a large voltage coefficient (such as general purpose ceramics) must be avoided since these can degrade signal linearity. If active circuitry precedes the ADC, it is recommended that the above RC filter is placed between the active circuitry and the AINR and AINL pins. The above example frequencies scale linearly with output sample rate.

The on-chip voltage reference and the common mode voltage are available at VREF and VCOM for the purpose of decoupling only. However, due

to the sensitivity of this node, the circuit traces attached to these pins must be minimal in length and no load current may be taken from VREF. It is possible to use VCOM as a reference voltage to bias the input buffer circuits, if the circuit trace is very short and VCOM is buffered at the converter (refer to the CDB53965/97). The recommended decoupling scheme for VREF, Figure 1, is a 470 μF electrolytic capacitor and a 0.1 μF ceramic capacitor connected from VREF to AGND. The recommended decoupling scheme for VCOM, Figure 1, is a 100 μF electrolytic capacitor and a 0.1 μF ceramic capacitor connected from VCOM to AGND.

GROUNDING AND POWER SUPPLY DECOUPLING - ALL MODES

As with any high resolution converter, the ADC requires careful attention to power supply and grounding arrangements if its potential performance is to be realized. Figure 1 shows the recommended power arrangements, with VA and VL connected to a clean +5 V supply. VD, which powers the digital filter, should be run from the system +5 V logic supply, provided that it is not excessively noisy (< ±50 mV pk-to-pk). Decoupling capacitors should be as near to the ADC as possible, with the low value ceramic capacitor being the nearest.

The printed circuit board layout should have separate analog and digital regions and ground planes, with the ADC straddling the boundary. All signals, especially clocks, should be kept away from the VREF pin in order to avoid unwanted coupling into the modulators. The VREF decoupling capacitors, particularly the 0.01 μF, must be positioned to minimize the electrical path from VREF and pin 3, AGND. The CDB5396/97 evaluation board demonstrates the optimum layout and power supply arrangements, as well as allowing fast evaluation of the ADC.

To minimize digital noise, connect the ADC digital outputs only to CMOS inputs.

DIGITAL FILTER PLOTS

Figures 9-24 show the performance of the digital filters included in the ADC. All plots are normalized to F_s . Assuming a sample rate of 48 kHz, the

0.5 frequency point on the plot refers to 24 kHz. The filter frequency response scales precisely with F_s .

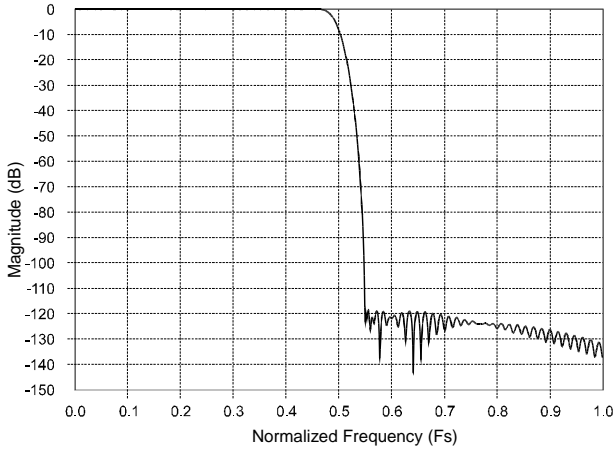


Figure 9. CS5396 Stop Band Attenuation

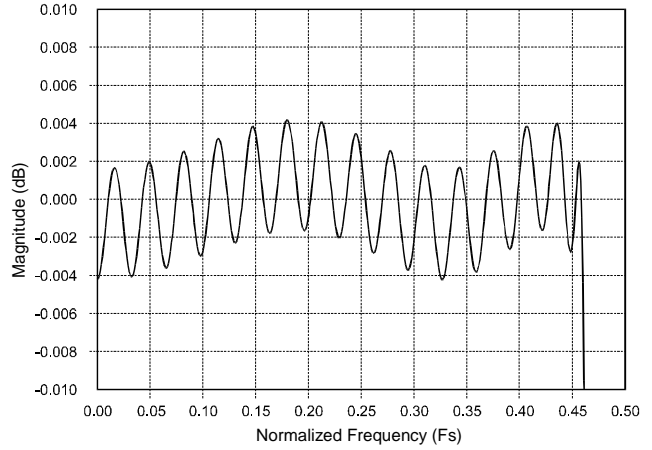


Figure 10. CS5396 Passband Ripple

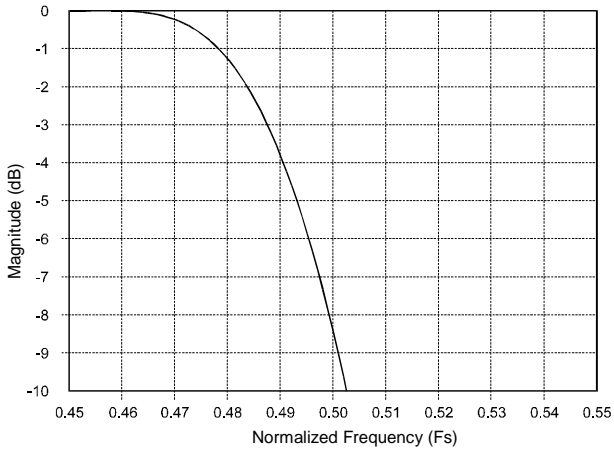


Figure 11. CS5396 Transition Band

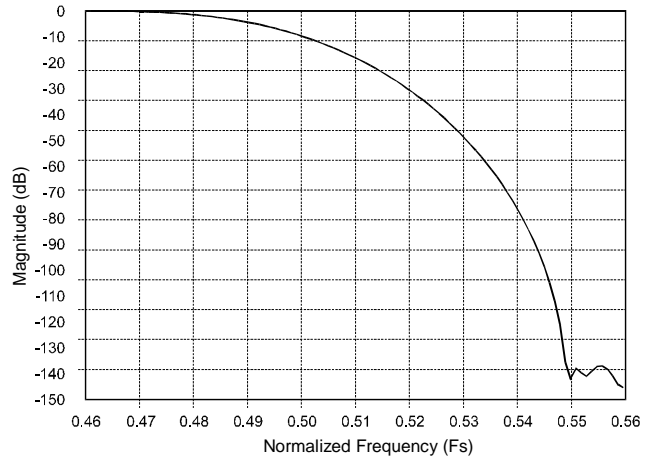


Figure 12. CS5396 Transition Band

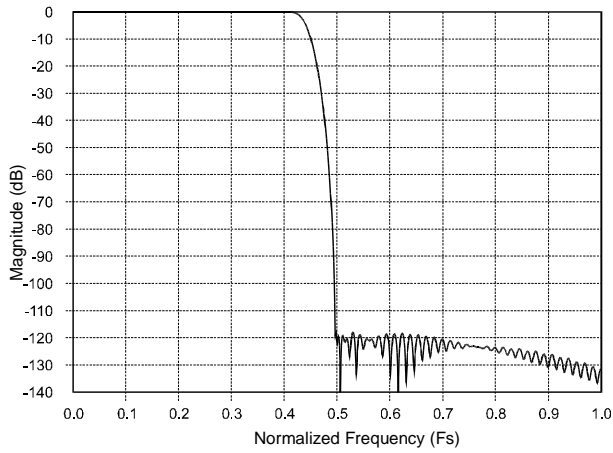


Figure 13. CS5397 Stop Band Attenuation

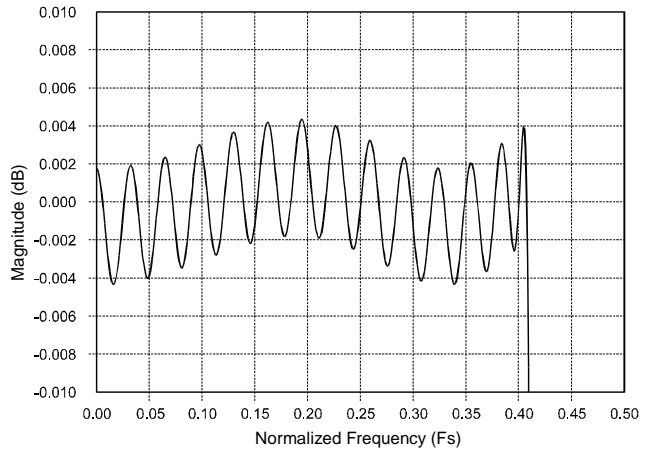


Figure 14. CS5397 Passband Ripple

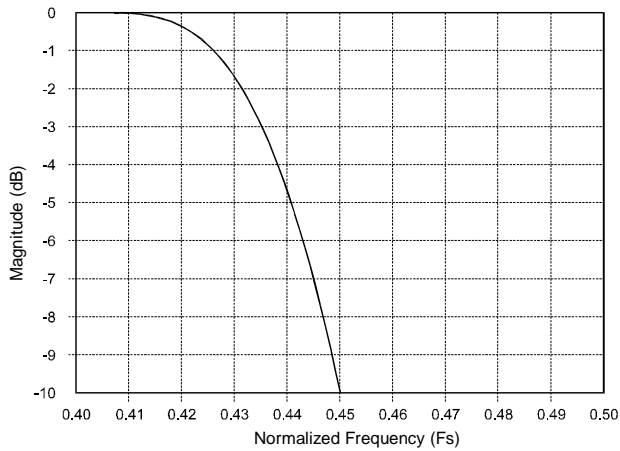


Figure 15. CS5397 Transition Band

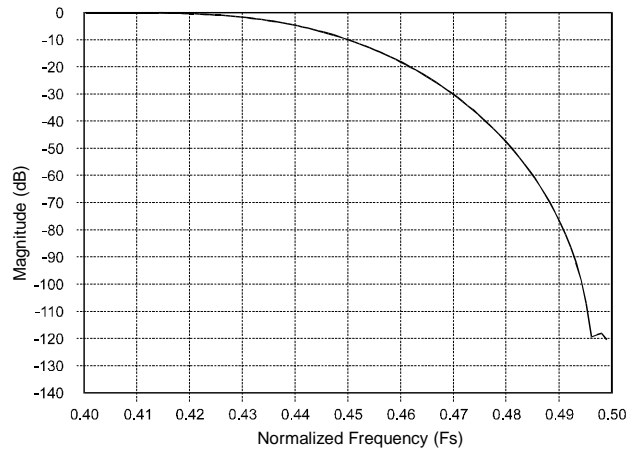
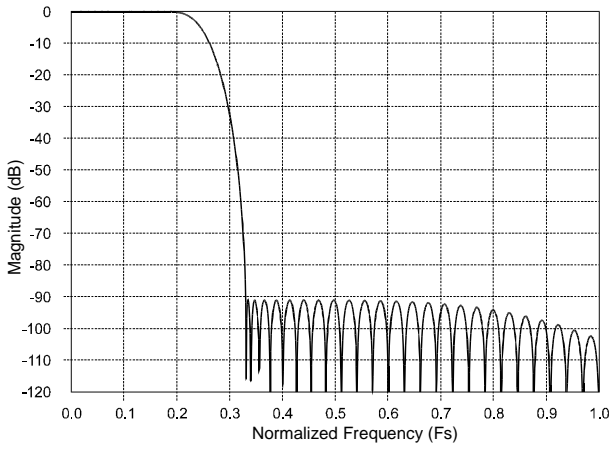
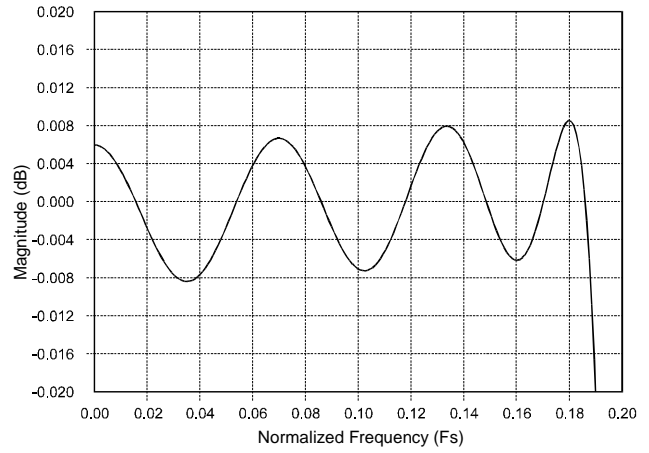


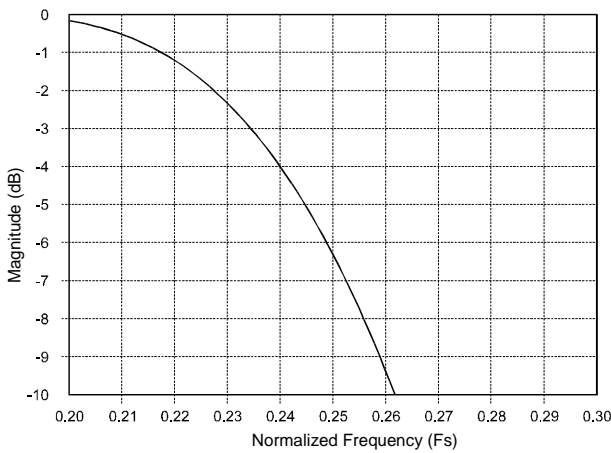
Figure 16. CS5397 Transition Band



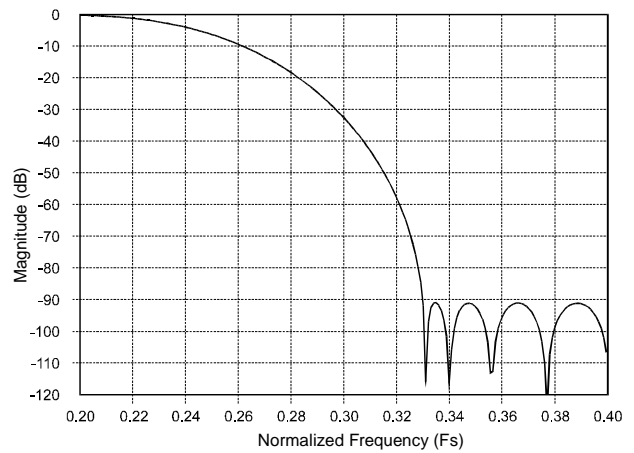
**Figure 17. Low Group Delay Filter
Stop Band Attenuation
64x Oversampling Mode**



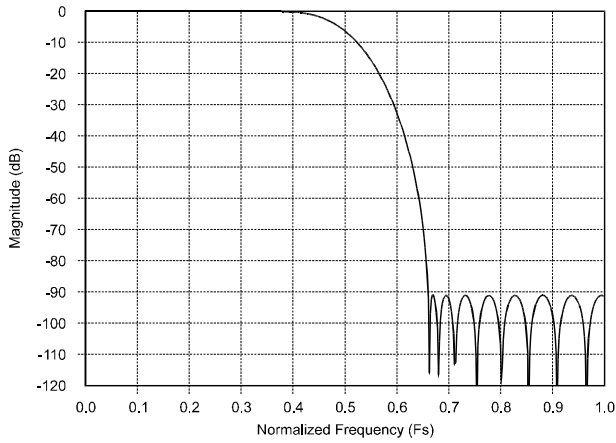
**Figure 18. Low Group Delay Filter
Passband Ripple
64x Oversampling Mode**



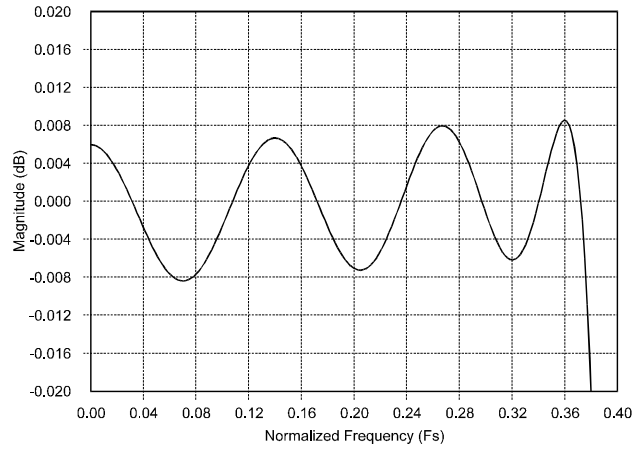
**Figure 19. Low Group Delay Filter
Transition Band
64x Oversampling Mode**



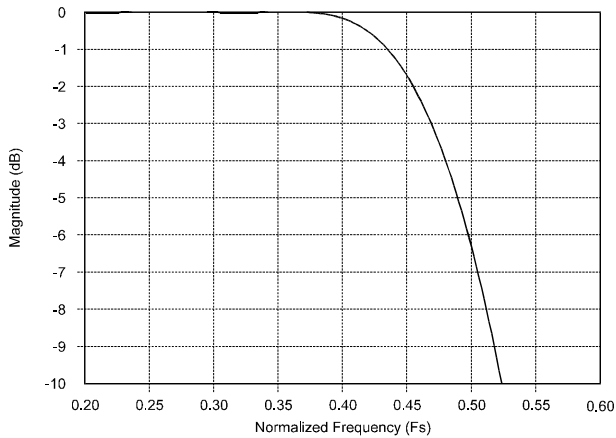
**Figure 20. Low Group Delay Filter
Transition Band
64x Oversampling Mode**



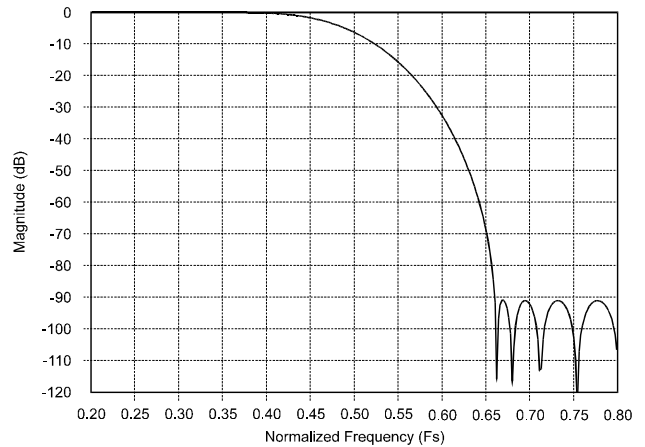
**Figure 21. Low Group Delay Filter
Stop Band Attenuation
128x Oversampling Mode**



**Figure 22. Low Group Delay Filter
Passband Ripple
128x Oversampling Mode**



**Figure 23. Low Group Delay Filter
Transition Band
128x Oversampling Mode**



**Figure 24. Low Group Delay Filter
Transition Band
128x Oversampling Mode**

REGISTER DESCRIPTION

** "default" ==> bit status after power-up-sequence

Analog control (address 00000001)

7	6	5	4	3	2	1	0
FSTART	GNDCAL	AAPD	ADPD	1BIT			
0	0	0	0	0			

FSTART (Frame start)Default = '0'.

This bit must be set to '1' to synchronize the modulator output and the decimation filter input and is automatically reset to '0' after a "fstart" pulse is sent to the analog and digital block.

GNDCAL (Ground calibration enable)

Default = '0'.

Modulator input is tied to internal "Vcom" when this bit is '1'.

AAPD (Analog Section of modulator in power down)

Default = '0'.

The analog section of the modulator is in power down mode when aapd = '1'.

ADPD (Digital Section of modulator in power down)

Default = '0'.

The digital section on the modulator is in power down mode when adpd = '1'.

TEST BIT

Default = '0'.

Must remain at 0.

Mode (address 00000010)

7	6	5	4	3	2	1	0
128x/64x	CAL	CHANGE_SIGN	_LR/LL	_HPEN	S/_M	DFS	MUTE
0	0	0	0	0	0	0	0

128x/64x

Default = '0'.

Oversampling ratio is 128 when this bit is '1' and 64 when this bit is '0'.

CAL (System calibration enable)

Default = '0'.

Setting this bit to '1' will initiate calibration.

This bit is automatically reset to '0' following calibration.

Change_sign (Change Sign enable)

Default = '0'.

A '1' will interchange the analog input paths within each channel resulting in a phase inversion of the analog signal. This bit applies to both channels.

_LR/LL (Left-Right output disable) Default = '0'.

If this bit is '0', SDATA1 will output the Left and Right channel data from the sdata1 source and SDATA2 will output the Left and Right channel data from the sdata2 source as described elsewhere in the data sheet.

If this bit is set to '1', the Left channel data from sdata1 source and sdata2 source (stored in Audio port register) will be sent out in SDATA1. SDATA2 will output all the Right channel data.

HPEN (HP enable) Default = '0'.

The highpass filter will be disabled when `_HPEN = '1'`. The highpass filter will be automatically enabled following calibration.

S/_M (Slave / Master mode) Default = '0'.

In master mode, LRCK, and SCLK are outputs. In slave mode, LRCK and SCLK are inputs. This bit is ignored when sdata1 is used as input port in "fir2in" or "psychoin" mode (refer to Digital control & Tag register and Appendix B).

DFS (Digital Format Select) Default = '0'.

Output of serial data complies with I²S standard when DFS is 1.
Output of serial data is Left Justified when DFS is 0.

MUTE

Default = '0'.

Data at SDATA1 and SDATA2 is always '0' when this set to '1'.

Audio port (address 00000011)

7	6	5	4	3	2	1	0
24BIT (SDATA1)	24BIT (SDATA2)	PSYCHO (SDATA1)	PSYCHO (SDATA2)	PSEL18/_16	PSEL20/_16	LGD (SDATA1)	LGD (SDATA2)
1	0	0	0	0	0	0	1

24bit(SDATA1)

Default = '1'.

A '1' enables the serial audio port 1 to transmit the 24-bit high precision output. This bit must be set to '0' to enable other SDATA1 output options.

24bit(SDATA2)

Default = '0'.

A '1' enables the serial audio port 2 to transmit 24-bit high precision output. This bit must be set to '0' to enable other SDATA2 output options.

psycho(SDATA1)

Default = '0'.

psychoacoustic output will be the data at the serial audio port 1 if this bit is '1' and all other bits of the port are set to '0'.

psycho(SDATA2)

Default = '0'.

psychoacoustic output will be the data at the serial audio port 2 if this bit is '1' and all other bits of the port are set to '0'.

pse18/_16(Psycho 18bit or 16bit)

Default = '0'.

This bit indicates the number of output bit if the psychoacoustic filter is chosen as output. A '0' here allows 16 bits output whereas a '1' allows 18 bits output as long as "pse120/_16" is '0'.

pse120/_16(Psycho 20bit)

Default = '0'.

This bit has the highest priority when setting the number of output bit of psychoacoustic filter. If this bit is '1', the output is set to 20-bit regardless of the status of "pse18/_16".

LGD(sdata1)

Default = '0'.

24-bit low-group-delay filter output will go through a highpass filter if "_hpen" bit in the Mode

register is '0'. The LGD output will be the data at the serial audio port 1 if this bit is '1' and all other bits of the port set to '0'.

LGD(sdata2) Default = '1'.
 24-bit low-group-delay filter output will go through a high passfilter if “_hpen” bit in the Mode register is '0'. If “_hpen” is '1', data at the serial audio port will derive directly from the LGD filter output.
 If more than 1 bit is set for sdata2, low-group-delay filter output will be selected for output at the port.

Test Mode 0(address 00000100)

7	6	5	4	3	2	1	0
AOVERFLOW	DOVERFLOW	FIR1_EN	FIR1(LRCK)	_PSYDITHER	DSTART1	DSTART0	
0	0	0	0	0	0	0	

aoverflow A '1' indicates an overflow condition occurs in the modulator. This bit is reset by reading the register.

doverflow A '1' indicates an overflow condition occurs in the decimation filter. This bit is reset by reading the register.

fir1_en(sdata) Default = '0'.
 Test purpose only.

fir1L_R(fir1 L channel enable)
 Default = '0'.
 Test purpose only.

_psydither(psychoacoustic filter dither disable)
 Default = '0'.
 A '0' means adding dither in the psychoacoustic filter.

dstart1, dstart2(dstart control bits)
 Default = '00'.
 Test purpose only.

Test Mode 1(add 00000101)

7	6	5	4	3	2	1	0
TEST MODE. RESERVED FOR FACTORY USE ONLY							

FOR FACTORY USE ONLY

Chip Address (address 00000110)

7	6	5	4	3	2	1	0
	CADDR6	CADDR5	CADDR4	CADDR3	CADDR2	CADDR1	CADDR0
	0	0	0	0	0	0	0

caddr(6-0) (chip address (bit6 to bit0))

Default = '0000000'.

This is used to store the programmable chip address for I²C and SPI mode.

When more than 1 device are connected to the I²C or SPI buses and using chip address is necessary, chip address set up is done by:

- 1) Hold the SDATA1 pin of every chip to '1' during power up.
- 2) Release the SDATA1 pin of the chip that is going to be programmed with chip address.
- 3) Send chip address and "addren"='1' (in Register 7) through the serial control port. (The remaining devices will not respond to this request.)
- 4) Repeat step 2) and step 3) for other chips one-by-one. (SDATA1 output is tri-stated until it is released from pull up.)

Digital Control & Peak Signal Level (address 00000111)

7	6	5	4	3	2	1	0
ADDREN	PKEN	PKUPDATE	HR/_BG		DDPD	FIR2IN	PSYCHOIN
0	0	0	0		0	0	0

addren(chip address enable)

Default = '0'.

When this bit is '0', no chip address comparison is done. The chip will response to all the request from Control Port.

When this bit is '1', the chip responds to the μ C only if the chip address from the μ C matches the chip address stored in "caddr(6-0)".

pken(PEAK enable) Default = '0'.

PSL bits calculation is based on the high precision 24-bit output.

PSL bits output follows the serial audio port that sends out 24-bit data.

If this bit is disabled, the PSL bits location on the output stream will be replaced by zeros.

pkupdate(PEAK update)

Default = '0'.

A '0' to '1' transition will load the peak value (since the last update) to the appropriate serial audio port. The internal peak register will then reset to '0'.

hr/_bg(PEAK display format)

Default = '0'.

High resolution tag format (hr/_bg='1') converts the 24-bit decimation filter output into 1 dB step. Bar Graph tag format (hr/_bg='0') allows LCD display format of the 24-bit output with 8 discrete values.

ddpd(digital filter power down enable)

Default = '0'.

The digital filter and serial audio port is in power down mode when ddpd = '1'.

fir2in(external fir2 input enable)

Default = '0'.

Input of 2nd stage decimation filter is taken from the sdata2 port. The input data will be decimated by 2 and then output to sdata1 of serial audio port.

psychoin (external psychoacoustic filter input enable)

Default = '0'.

Input of psychoacoustic filter is taken from the sdata2 port. The 24-bit input data will be truncated in psychoacoustic filter to the chosen output word length and then output to sdata1 of serial audio port.

R_cal_coeff (address 00001000 - 00001010)

7	6	5	4	3	2	1	0
RALPHA (BIT7)	RALPHA (BIT6)	RALPHA (BIT5)	RALPHA (BIT4)	RALPHA (BIT3)	RALPHA (BIT2)	RALPHA (BIT1)	RALPHA (BIT0)
0	0	0	0	0	0	0	0
RALPHA (BIT15)	RALPHA (BIT14)	RALPHA (BIT13)	RALPHA (BIT12)	RALPHA (BIT11)	RALPHA (BIT10)	RALPHA (BIT9)	RALPHA (BIT8)
0	0	0	0	0	0	0	0
RALPHA (BIT23)	RALPHA (BIT22)	RALPHA (BIT21)	RALPHA (BIT20)	RALPHA (BIT19)	RALPHA (BIT18)	RALPHA (BIT17)	RALPHA (BIT16)
0	1	0	0	0	0	0	0

Default = '0000 0000 0000 0000 0100 0000'. (represents 1)

The right channel calibration factor is stored in these registers with MSB in bit 7 of register address 00001010.

This value is updated after every calibration cycle.

User can read from or write to this calibration factor through the serial control port.

L_cal_coeff (address 00001011 - 00001101)

7	6	5	4	3	2	1	0
LALPHA (BIT7)	LALPHA (BIT6)	LALPHA (BIT5)	LALPHA (BIT4)	LALPHA (BIT3)	LALPHA (BIT2)	LALPHA (BIT1)	LALPHA (BIT0)
0	0	0	0	0	0	0	0
LALPHA (BIT15)	LALPHA (BIT14)	LALPHA (BIT13)	LALPHA (BIT12)	LALPHA (BIT11)	LALPHA (BIT10)	LALPHA (BIT9)	LALPHA (BIT8)
0	0	0	0	0	0	0	0
LALPHA (BIT23)	LALPHA (BIT22)	LALPHA (BIT21)	LALPHA (BIT20)	LALPHA (BIT19)	LALPHA (BIT18)	LALPHA (BIT17)	LALPHA (BIT16)
0	1	0	0	0	0	0	0

Default = '0000 0000 0000 0000 0100 0000'. (represents 1)

The left channel calibration factor is stored in these registers with MSB in bit 7 of register address 00001101.

This value is updated after every calibration cycle.

User can read from or write to this calibration factor through the serial control port.

L_offset (address 00001110)

7	6	5	4	3	2	1	0
LOS(BIT13)	LOS(BIT12)	LOS(BIT11)	LOS(BIT10)	LOS(BIT9)	LOS(BIT8)	LOS(BIT7)	LOS(BIT6)
0	0	0	0	0	0	0	0

Default = '0000 0000'.

User can read or write this offset through the serial control port.

R_offset (address 00001111)

7	6	5	4	3	2	1	0
ROS(BIT13)	ROS(BIT12)	ROS(BIT11)	ROS(BIT10)	ROS(BIT9)	ROS(BIT8)	ROS(BIT7)	ROS(BIT6)
0	0	0	0	0	0	0	0

Default = '0000 0000'.

User can read or write this offset through the serial control port.

Psycho coeff (address 00010000 - 00011000)

7	6	5	4	3	2	1	0
PC8(BIT8)	PC8(BIT7)	PC0(BIT5)	PC8(BIT4)	PC8(BIT3)	PC8(BIT2)	PC8(BIT1)	PC8(BIT0)
1	1	0	1	1	0	1	0
PC7(BIT8)	PC7(BIT7)	PC1(BIT5)	PC7(BIT4)	PC7(BIT3)	PC7(BIT2)	PC7(BIT1)	PC7(BIT0)
0	0	1	1	0	1	0	1
PC6(BIT8)	PC6(BIT7)	PC2(BIT5)	PC6(BIT4)	PC6(BIT3)	PC6(BIT2)	PC6(BIT1)	PC6(BIT0)
1	1	0	0	0	0	1	0
PC5(BIT8)	PC5(BIT7)	PC3(BIT5)	PC5(BIT4)	PC5(BIT3)	PC5(BIT2)	PC5(BIT1)	PC5(BIT0)
0	1	0	0	0	0	1	1
PC4(BIT8)	PC4(BIT7)	PC4(BIT5)	PC4(BIT4)	PC4(BIT3)	PC4(BIT2)	PC4(BIT1)	PC4(BIT0)
1	1	0	0	1	0	1	1
PC3(BIT8)	PC3(BIT7)	PC5(BIT5)	PC3(BIT4)	PC3(BIT3)	PC3(BIT2)	PC3(BIT1)	PC3(BIT0)
0	0	1	0	0	0	1	1
PC2(BIT8)	PC2(BIT7)	PC6(BIT5)	PC2(BIT4)	PC2(BIT3)	PC2(BIT2)	PC2(BIT1)	PC2(BIT0)
1	1	1	0	1	1	0	0
PC1(BIT8)	PC1(BIT7)	PC7(BIT5)	PC1(BIT4)	PC1(BIT3)	PC1(BIT2)	PC1(BIT1)	PC1(BIT0)
0	0	0	0	1	0	0	1
PC0(BIT8)	PC0(BIT7)	PC8(BIT5)	PC0(BIT4)	PC0(BIT3)	PC0(BIT2)	PC0(BIT1)	PC0(BIT0)
1	1	1	1	1	1	1	1

H1 Default = '1101 1010'.

H2 Default = '0011 0101'.

H3 Default = '1100 0010'.

H4 Default = '0100 0011'.

H5 Default = '1100 1011'.

H6 Default = '0010 0011'.

H7 Default = '1110 1100'.

H? Default = '0000 1001'.

H8 Default = '1111 1111'.

Psychoacoustic filter coefficients.

2's complement representation. 4 MSB bits represent left of binary point. 4 LSB represent right of binary point. User can read or write one or all of the coefficients through the serial control port.

PIN DESCRIPTIONS

VOLTAGE REFERENCE	VREF	□ 1	28	□ AGND	ANALOG GROUND
COMMON MODE VOLTAGE OUTPUT	VCOM	□ 2	27	□ AINR+	RIGHTCHANNEL ANALOG INPUT+
ANALOG GROUND	AGND	□ 3	26	□ AINR-	RIGHT CHANNEL ANALOG INPUT-
LEFT CHANNEL ANALOG INPUT+	AINL+	□ 4	25	□ AGND	ANALOG GROUND
LEFT CHANNEL ANALOG INPUT-	AINL-	□ 5	24	□ VA	POSITIVE ANALOG POWER
ANALOG CONTROL DATA INPUT	ADCTL	□ 6	23	□ VL	ANALOG SECTION LOGIC POWER
ANALOG SECTION CLOCK INPUT	MCLKA	□ 7	22	□ LGND	ANALOG SECTION LOGIC GROUND
TEST OUTPUT	TSTO1	□ 8	21	□ TSTO2	TEST OUTPUT
CONTROL DATA OUTPUT	DACTL	□ 9	20	□ MCLKD	DIGITAL SECTION CLOCK INPUT
See Descriptions	CAL	□ 10	19	□ CS / PDN	See Descriptions
DIGITAL SECTION POWER	VD	□ 11	18	□ CDIN / DFS	See Descriptions
DIGITAL GROUND	DGND	□ 12	17	□ CCLK / (S/M)	See Descriptions
LEFT/RIGHT SELECT	LRCK	□ 13	16	□ SDATA1	SERIAL DATA OUTPUT #1
SERIAL DATA CLOCK	SCLK	□ 14	15	□ SDATA2	SERIAL DATA OUTPUT #2

Power Supply Connections
VA - Positive Analog Power, Pin 24.

Positive analog supply. Nominally +5 volts.

VL - Positive Logic Power, Pin 23.

Positive logic supply for the analog section. Nominally +5 volts.

AGND - Analog Ground, Pin 3, 25 and 28.

Analog ground reference.

LGND - Logic Ground, Pin 22

Ground for the logic portions of the analog section.

VD - Positive Digital Power, Pin 11.

Positive supply for the digital section. Nominally +5 volts.

DGND - Digital Ground, Pin 12.

Digital ground for the digital section.

Analog Inputs
AINR-, AINR+ - Differential Right Channel Analog Inputs, Pin 26, 27.

Analog input connections for the right channel differential inputs. Nominally 4.0 Vpp differential for full-scale digital output.

AINL-, AINL+ - Differential Left Channel Analog Inputs, Pin 4,5.

Analog input connections for the left channel differential inputs. Nominally 4.0 Vpp differential for full-scale digital output.

Analog Outputs

VCOM - Common Mode Voltage Output, Pin 2.

Nominally +2.5 volts. Requires a 100 μ F electrolytic capacitor in parallel with 0.1 μ F ceramic capacitor for decoupling to AGND. Caution is required if this output is to be used to bias the analog input buffer circuits. Refer to text.

VREF - Voltage Reference Output, Pin 1.

Nominally +4.0 volts. Requires a 470 μ F electrolytic capacitor in parallel with 0.1 μ F ceramic capacitor for decoupling to AGND.

Digital Inputs

ADCTL - Analog Control Input, Pin 6.

Must be connected to DACTL. This signal enables communication between the analog and digital circuits.

MCLKA - Analog Section Input Clock, Pin 7.

This clock is internally divided and controls the delta-sigma modulators. The required MCLKA frequency is determined by the desired output sample rate (F_s). MCLKA of 24.576 MHz corresponds to an F_s of 96 kHz in 64x Oversampling Mode and 48 kHz in 128x Oversampling Mode.

MCLKD - Digital Section Input Clock, Pin 20.

MCLKD clocks the digital filter and must be connected to MCLKA. The required MCLKD frequency is determined by the desired output sample rate (F_s). MCLKD of 24.576 MHz corresponds to an F_s of 96 kHz in 64x Oversampling Mode and 48 kHz in 128x Oversampling Mode.

Digital Input Pin Definitions for Stand-Alone MODE

DFS - Digital Format Select, Pin 18.

The relationship between LRCK, SCLK and SDATA is controlled by the DFS pin. When high, the serial output data format is I²S compatible. The serial data format is left-justified when low.

PDN - Power-Down, Pin 19.

When high, the device enters power-down. Upon returning low, the device enters normal operation. Calibration of the device is required following release of power-down.

S/M - Slave or Master Mode, Pin 17.

When high, the device is configured for Slave mode where LRCK and SCLK are inputs. The device is configured for Master mode where LRCK and SCLK are outputs when S/M is low.

CAL - Calibration, Pin 10.

Activates the calibration of the tri-level delta-sigma modulator.

Digital Pin Definitions for CONTROL-PORT MODE**CDIN - Control Port Data Input, Pin 18.**

Control port data input for SPI mode.
Control port data input and output for I²C mode.

CS - Chip Select Input, Pin 19.

Control port chip select for SPI mode. The CS5396/97 monitors the state of \overline{CS} during power-up and will configure to an SPI interface if this pin is held low. Conversely, if held high, the port will configure to a I²C interface.

CCLK - Control Port Clock Input, Pin 17.

Control port clock input pin for both I²C and SPI modes.

CAL - Calibration, Pin 10.

CAL pin is not functional in Control Port Mode and should be connected to ground.

Digital Outputs**DACTL- Digital to Analog Control Output, Pin 9.**

Must be connected to ADCTL. This signal enables communication from the digital circuits to the analog circuits.

SDATA1 - Digital Audio Data Output #1, Pin 16.

Stand-Alone Mode - The 24-bit audio data is presented MSB first, in 2's complement format.
Control Port Mode - The 24 audio data bits are presented MSB first, in 2's complement format. The audio data can be followed by 8 Peak Signal Level bits which indicate the peak signal level. The additional audio data options include; 16, 18, or 20-bit data with or without psychoacoustically optimized dither; or the output of the Low Group Delay filter. The SDATA1 output is completely independent from SDATA2. The mode selection between Stand-Alone and Control Port mode is determined by the state of the SDATA1 pin during power-up. A 47 k Ω pull-up resistor on SDATA1 will select the Control Port mode. However, the control port will not response to CCLK and CDIN until the pull-up on the SDATA1 pin is released.

SDATA2 - Digital Audio Data Output #2, Pin 15.

Stand-Alone Mode - The 24-bit low group delay audio data is presented MSB first, in 2's complement format.
Control Port Mode - The 24-bit low group delay audio data is presented MSB first, in 2's complement format. The audio data can be followed by 8 peak detect bits which indicate the peak signal level. The additional audio data options include; the standard 24-bit word; 16, 18, or 20-bit data with or without psychoacoustically optimized dither. The SDATA2 output is completely independent from SDATA1.

Digital Inputs or Outputs

LRCK - Left/Right Clock, Pin 13.

LRCK determines which channel, left or right, is to be output on SDATA1 and SDATA2. In master mode, LRCK is an output whose frequency is equal to F_s . In Slave Mode, LRCK is an input whose frequency must be equal to F_s . Although the outputs for each channel are transmitted at different times, Left/Right pairs represent simultaneously sampled analog inputs.

Stand-Alone Mode - The relationship between LRCK, SCLK and SDATA is controlled by the Digital Format Select (DFS) pin.

Control Port Mode - The relationship between LRCK, SCLK and SDATA is controlled by the control register.

SCLK - Serial Data Clock, Pin 14.

Stand-Alone Mode- Clocks the individual bits of the serial data from SDATA1 and SDATA2. In master mode, SCLK is an output clock at $64 \times F_s$. In slave mode, SCLK is an input which requires a continuously supplied clock at any frequency from $48 \times F_s$ to $128 \times F_s$ ($64 \times F_s$ is recommended). The relationship between LRCK, SCLK and SDATA is controlled by the Digital Format Select (DFS) pin.

Control Port Mode - Clocks the individual bits of the serial data from SDATA1 and SDATA2. In master mode, SCLK is an output clock at $128 \times$ the output sample rate in the $128 \times$ Oversampling Mode and $64 \times$ the output sample rate in the $64 \times$ Oversampling Mode.

In slave mode, SCLK is an input, which requires a continuously supplied clock at any frequency from $32 \times$ to $128 \times$ the output sample rate. A $128 \times$ SCLK is preferred in the $128 \times$ Oversampling Mode and $64 \times$ SCLK is preferred in the $64 \times$ Oversampling Mode. The relationship between LRCK, SCLK and SDATA is controlled by the control register.

Miscellaneous

TSTO1, TSTO2 - Test Outputs, Pins 8 and 21.

These pins are intended for factory test outputs. They must not be connected to any external component or any length of circuit trace.

PARAMETER DEFINITIONS

Dynamic Range

The ratio of the rms value of the signal to the rms sum of all other spectral components over the specified bandwidth. Dynamic Range is a signal-to-noise ratio measurement over the specified bandwidth made with a -60 dBFS signal. 60 dB is added to resulting measurement to refer the measurement to full-scale. This technique ensures that the distortion components are below the noise level and do not affect the measurement. This measurement technique has been accepted by the Audio Engineering Society, AES17-1991, and the Electronic Industries Association of Japan, EIAJ CP-307. Expressed in decibels.

Total Harmonic Distortion + Noise

The ratio of the rms value of the signal to the rms sum of all other spectral components over the specified band width (typically 10 Hz to 20 kHz), including distortion components. Expressed in decibels. Measured at -1 and -20 dBFS as suggested in AES17-1991 Annex A.

Frequency Response

A measure of the amplitude response variation from 10 Hz to 20 kHz relative to the amplitude response at 1 kHz. Units in decibels.

Interchannel Isolation

A measure of crosstalk between the left and right channels. Measured for each channel at the converter's output with no signal to the input under test and a full-scale signal applied to the other channel. Units in decibels.

Interchannel Gain Mismatch

The gain difference between left and right channels. Units in decibels.

Gain Error

The deviation from the nominal full-scale analog output for a full-scale digital input.

Gain Drift

The change in gain value with temperature. Units in ppm/°C.

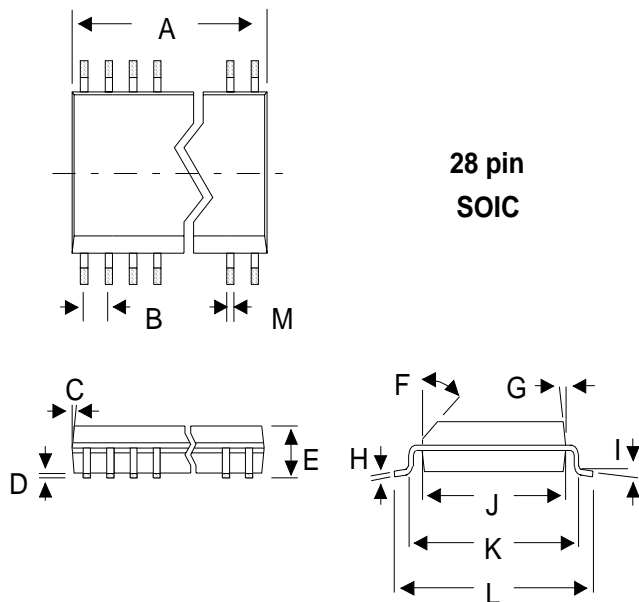
Offset Error

The deviation of the mid-scale transition (111...111 to 000...000) from the ideal. Units in mV.

ADDITIONAL INFORMATION

- 1) “Techniques to Measure and Maximize the Performance of a 120 dB, 24-bit, 96 kHz A/D Integrated Circuit” by Steven Harris, Steven Green and Ka Leung. Paper presented at the 103rd Convention of the Audio Engineering Society, September 1997.
- 2) “A 120 dB Dynamic Range, 96 kHz, 24-bit Analog-to-Digital Converter” by Kafai Leung, Sarah Zhu, Ka Leung and Eric Swanson. Paper presented at the 102nd Convention of the Audio Engineering Society, March 1997.
- 3) A 5 V, 118 dB Delta Sigma Analog-to-Digital Converter for Wideband Digital Audio by Ka Y. Leung, Eric J. Swanson, Kafai Leung, Sarah S. Zhu. Presented at ISSCC February, 1997, paper FP 13.6
- 4) “How to Achieve Optimum Performance from Delta-Sigma A/D and D/A Converters” by Steven Harris. Presented at the 93rd Convention of the Audio Engineering Society, October 1992.
- 5) “The Effects of Sampling Clock Jitter on Nyquist Sampling Analog-to-Digital Converters, and on Oversampling Delta Sigma ADCs” by Steven Harris. Paper presented at the 87th Convention of the Audio Engineering Society, October 1989.
- 6) “A Fifth-Order Delta-Sigma Modulator with 110 dB Audio Dynamic Range” by I. Fujimori, K. Hamashita and E.J. Swanson. Paper presented at the 93rd Convention of the Audio Engineering Society, October 1992.
- 7) “An 18-Bit Dual-Channel Oversampling Delta-Sigma A/D Converter, with 19-Bit Mono Application Example” by Clif Sanchez. Paper presented at the 87th Convention of the Audio Engineering Society, October 1989.
- 8) “A Stereo 16-bit Delta-Sigma A/D Converter for Digital Audio” by D.R. Welland, B.P. Del Signore, E.J. Swanson, T. Tanaka, K. Hamashita, S. Hara, K. Takasuka. Paper presented at the 85th Convention of the Audio Engineering Society, November 1988.

PACKAGE DIMENSIONS



DIM	MILLIMETERS		INCHES	
	MIN	MAX	MIN	MAX
A	17.53	18.03	0.690	0.710
B	1.27 BSC		0.050 BSC	
C	7° NOM		7° NOM	
D	0.127	0.330	0.005	0.013
E	2.41	2.67	0.095	0.105
F	45° NOM		45° NOM	
G	7° NOM		7° NOM	
H	0.203	0.381	0.008	0.015
I	2°	8°	2°	8°
J	7.42	7.59	0.292	0.298
K	8.76	9.02	0.345	0.355
L	10.16	10.67	0.400	0.420
M	0.33	0.51	0.013	0.020

APPENDIX A: 64X VS. 128X OVERSAMPLING MODES

Not available at this time.

APPENDIX B: EXTERNAL DATA INPUT TO DIGITAL FILTER

Not available at this time.

APPENDIX C: PSYCHOACOUSTIC FILTER

Not available at this time.

Evaluation Board for CS5394 and CS5396/7

Features

- Demonstrates recommended layout and grounding arrangements
- CS8404A generates AES/EBU and/or IEC 958 compatible digital audio
- Buffered serial output interface
- Digital and analog patch areas
- On-board or externally supplied system timing

General Description

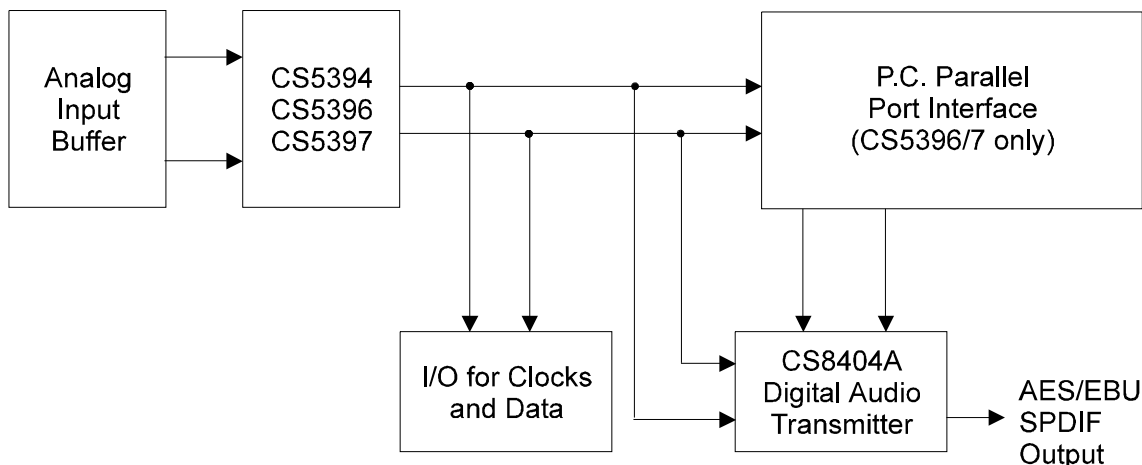
The CDB5394, CDB5396 and CDB5397 evaluation boards are an excellent means for quickly evaluating the CS5394, CS5396 and CS5397 24-bit, stereo A/D converters. Evaluation requires a digital signal processor, a low distortion analog signal source and a power supply. Analog inputs are provided via XLR connectors for both channels.

Also included is a CS8404A digital audio interface transmitter which generates AES/EBU, S/PDIF, and EIAJ-340 compatible audio data. The digital audio data is available via RCA phono and optical connectors.

The evaluation board may also be configured to accept external timing signals for operation in a user application during system development.

ORDERING INFORMATION:

CDB5394, CDB5396, CDB5397



Preliminary Product Information

This document contains information for a new product. Cirrus Logic reserves the right to modify this product without notice.

OVERVIEW

CDB5394/96/97 System

The CDB5394/96/97 evaluation boards are an excellent means of quickly evaluating the CS5394, CS5396 or CS5397. The CS8404A digital audio interface transmitter provides an easy interface to digital audio signal processors, including the majority of digital audio test equipment. The evaluation board has been designed to accept an analog input and provide optical and coaxial digital outputs. The evaluation board also allows the user to access clocks and data through a 10-pin header for system development.

The CDB5394/96/97 schematic has been partitioned into 7 schematics shown in Figures 2 through 8. Each partitioned schematic is represented in the system diagram shown in Figure 1. Notice that the system diagram also includes the connections between the partitioned schematics.

Power Supply Circuitry and Grounding

Power is supplied to the evaluation board by six binding posts as shown in Figure 8. +5VA provides 5 Volt power to the converter, VCOM buffer and the crystal oscillator. The +/-12V binding posts provide power to the analog input buffer. +5VD supplies 5 Volt power to the digital section of the board. Z1-Z4 are transient suppression diodes which also provide protection from incorrectly connected power supply leads.

Configuration for Stand-Alone or Control Port Mode

Refer to Tables 2-4 for the jumper settings required to configure the evaluation board.

Power-Down and Calibration - Stand alone Mode

The CS5394 and CS5396/97 in Stand-Alone mode are placed into the power-down mode simply by depressing the PDN switch (S1). Power-down is re-

leased when the PDN switch is released. A calibration sequence should be manually initiated by depressing the CAL switch (S2) following power-down.

Power-Down and Calibration - Control Port Mode for CDB5396/97 Only

Power-down and calibration are available only through the control port. The calibration and power-down buttons on the evaluation board are ignored when configured in the Control Port mode.

Supplied Control Port Commands for CDB5396/97

The evaluation board includes a set of DOS files which allow communication through a PC parallel port to the evaluation board.

The supplied commands include:

cal64x.bat - Performs a calibration and initialization sequence and sets the CS5396/97 into the 64X oversampling mode.

cal128x.bat - Performs a calibration and initialization sequence and sets the CS5396/97 into the 128X oversampling mode.

rdi2c.exe <Map>- This routine returns the value located in the register pointed to by <map>. The <map> value is in hex and the value returned is in hex.

wri2c.exe <map> <data> - This routine writes the value of <data> into the register pointed to by <map>. Both values are in hex.

rst.exe - Sends a reset command to the device.

mode128x.bat - Sets the device into the 128X oversampling mode. The cal128x.bat command includes this sequence.

mode64x.bat - Sets the device into the 64X oversampling mode. The cal64x.bat command includes this sequence.

gnd.bat - Disconnects the analog modulators from the input pins and attaches the modulator inputs to the internal common mode voltage.

ungnd.bat - Disconnects the analog modulators from the internal common mode voltage and attaches the modulator inputs to the input pins.

General Comments on the Parallel Port

The evaluation board will be partially powered through the PC cable when the supplies to the evaluation board are off. This will affect the RC timing circuit which places the CS5396/97 into the Control Port mode. It is required that the evaluation board go through the power-up sequence without the cable to the PC connected.

Input Buffer

The differential input circuit shown in Figure 4 is well-suited for the CS5394/96/7 in professional applications. The circuit will accept a differential or single-ended signal of either polarity and provide a differential signal with the proper DC offset to the CS5394 or CS5396/97. The circuit also incorporates 6 dB of attenuation to scale down professional input levels to the input voltage range of the CS5394/96/97. A nominal input level of 13 Volts rms to the evaluation board will achieve a full scale digital output from the CS5394/96/97. The common mode rejection of the system is limited by the passive component matching of the input buffer circuit. The analog input connector is a standard female XLR with Pin 2 positive, Pin 3 return, and Pin 1 shield.

R1, R5, R16 and C65 form an RC network which provides anti-alias filtering and the optimum source impedance for the CS5394/96/97 right channel inputs. R2, R3, R15 and C66 duplicate this function for the left channel. Notice that this circuit also provides approximately 13.25 dB attenuation to lower the noise contributed from the analog input buffer.

The CS5394/96/97 are able to withstand input currents of 100 mA maximum, as stated in the CS5394 and CS5396/7 data sheets. The OPA627 op-amp is not able to deliver 100 mA, so input protection diodes are not required. However, protection diodes are recommended if there is a possibility that over-range signals could be applied at the ADC inputs which exceed 100 mA. Refer to the Crystal application note, "AN10: A/D Converter Input Protection Techniques."

CS5394 and CS5396/7 A/D Converters

The CS5394/96/97 A/D converters are shown in Figure 2. A description of these devices are included in the CS5394 and CS5396/7 datasheets.

CS8404A Digital Audio Interface

Figure 4 shows the circuitry for the CS8404A digital audio interface transmitter. The CS8404A can implement AES/EBU, S/PDIF, and EIAJ-340 interface standards. The Digital Interface Format for the transmitter must be set to match the format chosen for the CS5394 or CS5396/7 as defined in Tables 2-4. SW2 provides 8 DIP switches to select various modes and bits for the CS8404A; switch definitions and the default settings for SW2 are listed in Tables 5-6. Digital outputs are provided on an RCA connector via an isolation transformer and on an optical transmitter. For more detailed information on the CS8404A and the digital audio standards, see the CS8403A/CS8404A data sheet.

I/O Port for Clocks and Data

A serial output interface is provided on I/O Port_1, as shown in Figure 6. When I/O Port is set to the MASTER position, MCLK, SCLK, LRCK and SDATA are outputs from I/O Port. When I/O Port is in the SLAVE position, MCLK and SDATA are outputs, while SCLK and LRCK become inputs. Hence, in SLAVE mode, the SCLK and LRCK signals must be externally derived from MCLK to run the ADC. All signals are buffered in order to isolate the converter from external circuitry. Note that the

CS5394/96/97 must also be properly configured for Slave or Master mode.

CS8404A Format Configuration

The CS5394/96/97 supports two Digital Interface Formats for both master and slave configurations. Format 0 has valid data on the rising edge of SCLK and the CS8404A has no corresponding mode. However, inverting SCLK so that data is valid on the falling edge of SCLK will make Format 0 of the CS5394/96/97 match Format 1 of the CS8404A. Jumpers are available to configure the CS8404A to Format 1 and perform inversion of SCLK. See Tables 4-6.

Digital Interface Format 1 is the I2S compatible mode and matches Format 4 of the transmitter. Refer to Tables 4-6 for jumper positions.

CS8404A MCLK Generation

The crystal oscillator (U5) is either 256x for the 64x oversampling mode or 512x for the 128x oversampling mode. However, the CS8404A requires a master clock frequency of 128x F_s . Therefore, the

MCLK must be divided by either 2 or 4 depending on the mode of operation. Refer to Tables 4-6 for the proper jumper selection.

Grounding and Power Supply Decoupling

The CS5394/96/97 require careful attention to power supply and grounding arrangements to optimize performance. The CS5394/96/97 is positioned over the analog ground plane.

This layout technique is used to minimize digital noise and to insure proper power supply matching/sequencing. The decoupling capacitors are located as close to the ADC as possible. Extensive use of ground plane fill on both the analog and digital sections of the evaluation board yield large reductions in radiated noise effects.

The evaluation board uses separate analog and digital ground planes which are joined at the converter. This arrangement isolates the analog circuitry from the digital logic.

CONNECTOR	INPUT/OUTPUT	SIGNAL PRESENT
+5VA	input	+5 Volts for analog section
+5VD	input	+5 Volts for digital section
±12V	input	±12 Volts for analog input
AGND	input	Analog ground connection from power source
DGND	input	Digital ground connection from power source
AINL	input	Left channel differential/single ended analog input
AINR	input	Right channel differential/single ended analog input
LRCK, SCLK	input/output	I/O for serial and left/right clocks
MCLK	output	Master clock output
SDATA	output	Serial data output
coaxial output	output	CS8404A digital output via transformer
optical output	output	CS8404A digital output via optical transmitter

Table 1: System Connections

Jumper	Purpose	Position	Function Selected
HDR1	Sets the proper pull-up for the parallel port	High Low	Selects a 2k pull-up for I2C compliance Invalid selection for uC mode
HDR7	Sets the proper pull-up for the parallel port	High Low	Selects a 2k pull-up for I2C compliance Invalid selection for uC mode
HDR8	Sets the proper pull-up for the parallel port	High Low	Selects a 2k pull-up for I2C compliance Invalid selection for Control Port mode
HDR10	Selects Stand-Alone or Control Port mode	High Low	Selects Control Port Mode Invalid selection for Control Port Mode
HDR11	Selects I2C or SPI mode for CS5396/97 control port	High Low	Selects I2C mode Selects SPI Mode
SDATA	Selection of data source for output from the SPDIF and I/O port	1 2	Selects SDATA1 Selects SDATA2
I/O Port	I/O port Slave or Master selection	Slave Master	LRCK and SDATA are inputs to the port. LRCK and SDATA are outputs from the port
8404A Mode 1 Mode 2 Mode 3	Sets CS8404A data format selection for CS5396/97 compatibility. All jumpers must be set to either I2S or LJ and be compatible with the CS5396/97 data format.	I2S LJ	I2S data format selected Left Justified data format selected
CS8404A	MCLK divide for CS8404 and CS5396/97 compatibility	128 x 64 x	Divide MCLK by 4 for 128x oversampling mode Divide MCLK by 2 for 64x oversampling mode
CS5396/97	Supports a future function of the CS5396/97	High Low	Invalid selection Should be set LOW

Bold indicates default settings

Table 2: CDB5396 and CDB5397 Control Port Mode jumper Setting

Jumper	Purpose	Position	Function Selected
HDR1	Secondary effect on power-down implementation	High Low	Invalid selection for Stand-alone Mode Must be set low for operation
HDR7	CS5396/97 digital data format selection	High Low	Selects I2S data format Selects Left justified data format
HDR8	CS5396/97 Master or Slave mode selection	High Low	Selects Slave Mode Selects Master Mode
HDR10	Selects Stand-alone or Control Port mode	High Low	Selects Control Port Mode Selects Stand-alone Mode
HDR11	Selects polarity of power-down	High Low	Must be set High Invalid selection, CDB will not function
SDATA	Selection of Data source for output from the SPDIF and I/O port	1 2	Selects SDATA1 Selects SDATA2
I/O Port	I/O port Slave or Master selection	Slave Master	LRCK and SDATA are inputs to the port LRCK and SDATA are outputs from the port
8404A Mode 1 Mode 2 Mode 3	Sets CS8404A data format selection for CS5396/97 compatibility. All jumpers must be set to either I2S or LJ and be compatible with the CS5396/97 data format (HDR7)	I2S LJ	I2S data format selected Left Justified data format selected
CS8404A	MCLK divide for CS8404 and CS5396/97 compatibility	128 x 64 x	Divide MCLK by 4 for 128x oversampling mode Divide MCLK by 2 for 64x oversampling mode
CS5396/97	Supports a future function of the CS5396/97	High Low	Invalid selection Should be set LOW

Table 3: CDB5396 and CDB5397 Stand-Alone Mode Jumper Settings

Jumper	Purpose	Position	Function Selected
HDR1	Secondary effect on power-down implementation	High Low	Invalid selection for Stand-alone Mode Must be set low for operation
HDR7	CS5394 digital data format selection	High Low	Selects I2S data format Selects Left justified data format
HDR8	CS5394 Master or Slave mode selection	High Low	Selects Slave Mode Selects Master Mode
HDR10	Selects Stand-alone or Control Port mode	High Low	Invalid selection for CS5394 Selects Stand-alone Mode
HDR11	Selects polarity of power-down	High Low	Must be set High Invalid selection, CDB will not function
SDATA	Selection of Data source for output from the SPDIF and I/O port	1 2	Selects SDATA1 Invalid selection for CS5394
I/O Port	I/O port Slave or Master selection	Slave Master	LRCK and SDATA are inputs to the port LRCK and SDATA are outputs from the port
8404A Mode 1 Mode 2 Mode 3	Sets CS8404A data format selection for CS5394 compatibility. All jumpers must be set to either I2S or LJ and be compatible with the CS5394 data format (HDR7)	I2S LJ	I2S data format selected Left Justified data format selected
CS8404A	MCLK divide for CS8404 and CS5394 compatibility	128 x 64 x	Invalid selection for CS5394 Divide MCLK by 2 for 64x oversampling mode
CS5396/97	Supports a future function of the CS5396/97	High Low	Invalid selection Should be set LOW

Table 4: CDB5394 Jumper Settings
 Bold indicates default settings

Switch#	0=Closed, 1=Open	Comment
6	$\overline{PRO}=0$	Consumer Mode (C0=0)
	FC1, FC0	C24,C25,C26,C27 - Sample Frequency
8, 5	0 0 *0 1 1 0 1 1	0000 - 44.1 kHz 0100 - 48 kHz 1100 - 32 kHz 0000 - 44.1 kHz, CD Mode
7	$\overline{C3}$	C3,C4,C5 - Emphasis (1 of 3 bits)
	*1 0	000 - None 100 - 50/15 μ s
4	$\overline{C2}$	C2 - Copy/Copyright
	*1 0	0 - Copy Inhibited/Copyright Asserted 1 - Copy Permitted/Copyright Not Asserted
3	$\overline{C15}$	C15 - Generation Status
	*1 0	0 - Definition is based on category code 1 - See CS8402A Data Sheet, App. A
	$\overline{C8}, \overline{C9}$	C8-C14 - Category Code (2 of 7 bits)
1, 2	1 1 1 0 0 1 *0 0	0000000 - General 0100000 - PCM encoder/decoder 1000000 - Compact Disk - CD 1100000 - Digital Audio Tape - DAT

Table 5: CS8404A Switch Definitions - Consumer Mode

Switch#	0=Closed, 1=Open	Comment
6	$\overline{PRO}=1$	Professional Mode (C0=1)
8	CRE	Local Sample Address Counter & Reliability Flags
	0 1	Disabled Internally Generated
7, 4	$\overline{C6}, \overline{C7}$	C6,C7 - Sample Frequency
	1 1 1 0 0 1 0 0	00 - Not Indicated - Default to 48 kHz 01 - 48 kHz 10 - 44.1 kHz 11 - 32 kHz
5	$\overline{C1}$	C1 - Audio
	1 0	0 - Normal Audio 1 - Non-Audio
3	$\overline{C9}$	C8,C9,C10,C11 - Channel Mode (1 of 4 bits)
	1 0	0000 - Not indicated - Default to 2-channel 0100 - Stereophonic
1, 2	EM1, EM0	C2,C3,C4 - Emphasis (2 of 3 bits)
	1 1 1 0 0 1 0 0	000 - Not Indicated - Default to none 100 - No Emphasis 110 - 50/15 μ s 111 - CCITT J.17

Table 6: CS8404A Switch Definitions - Professional Mode

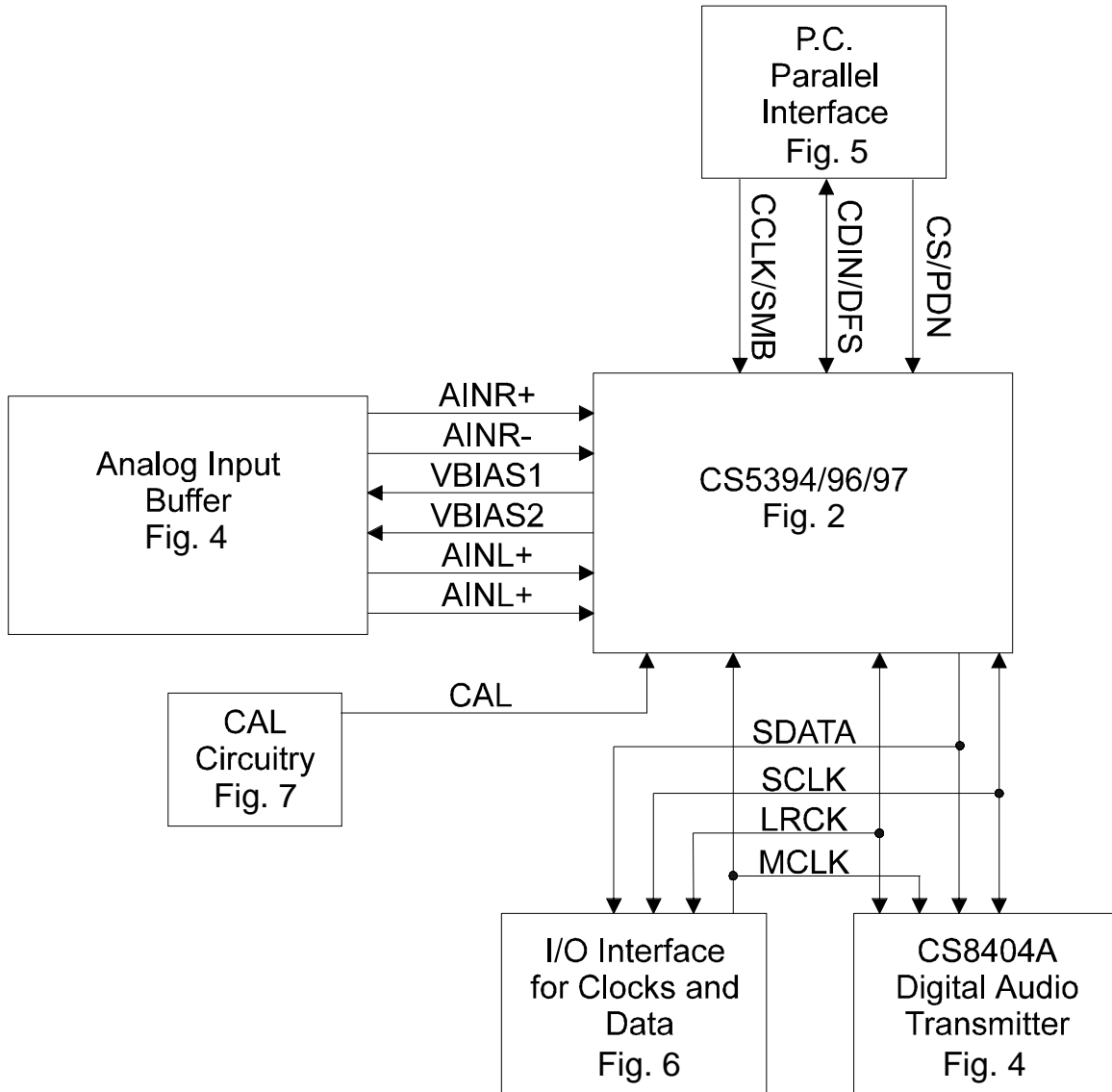


Figure 1. System Block Diagram and Signal Flow

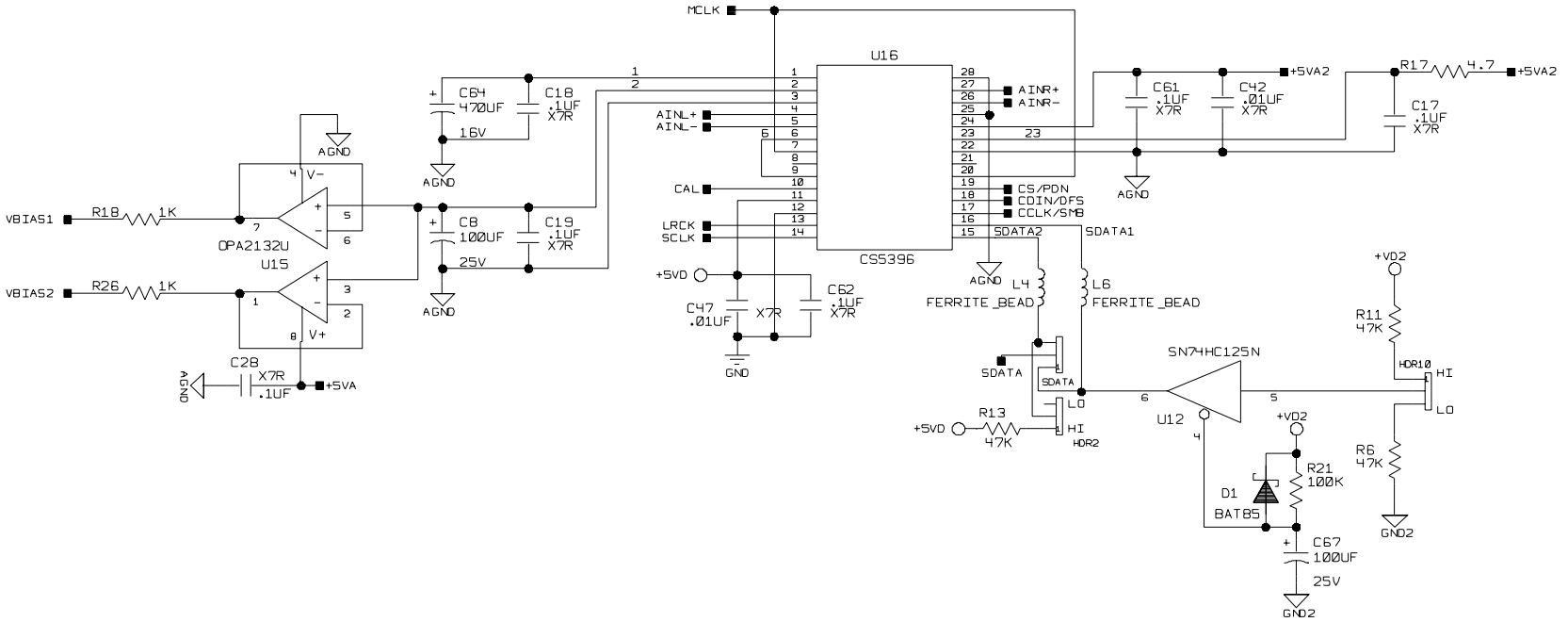


Figure 2. CS5394 and CS5396/7 Connections

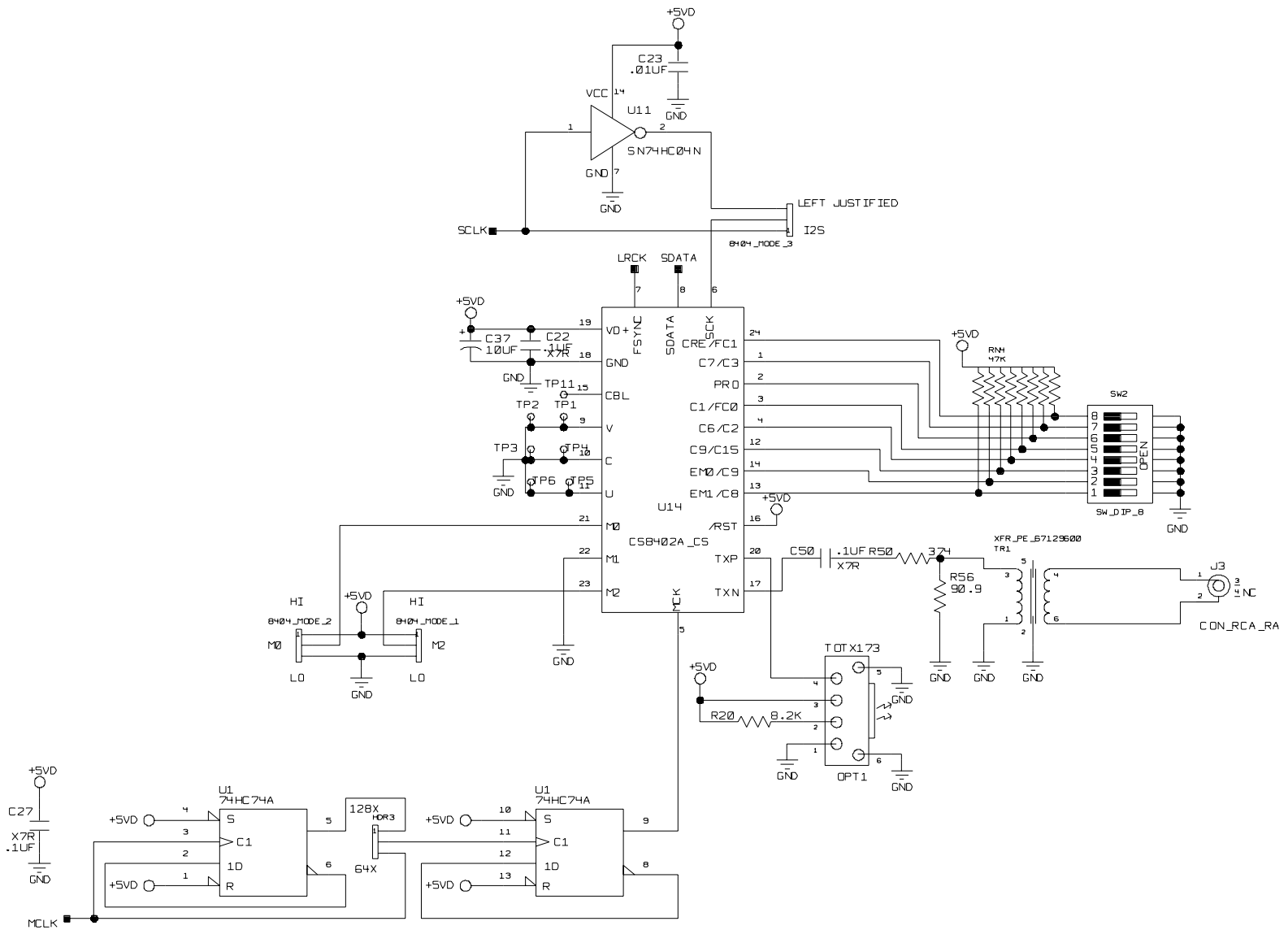


Figure 3. CS8404A Digital Audio Transmitter and Connections

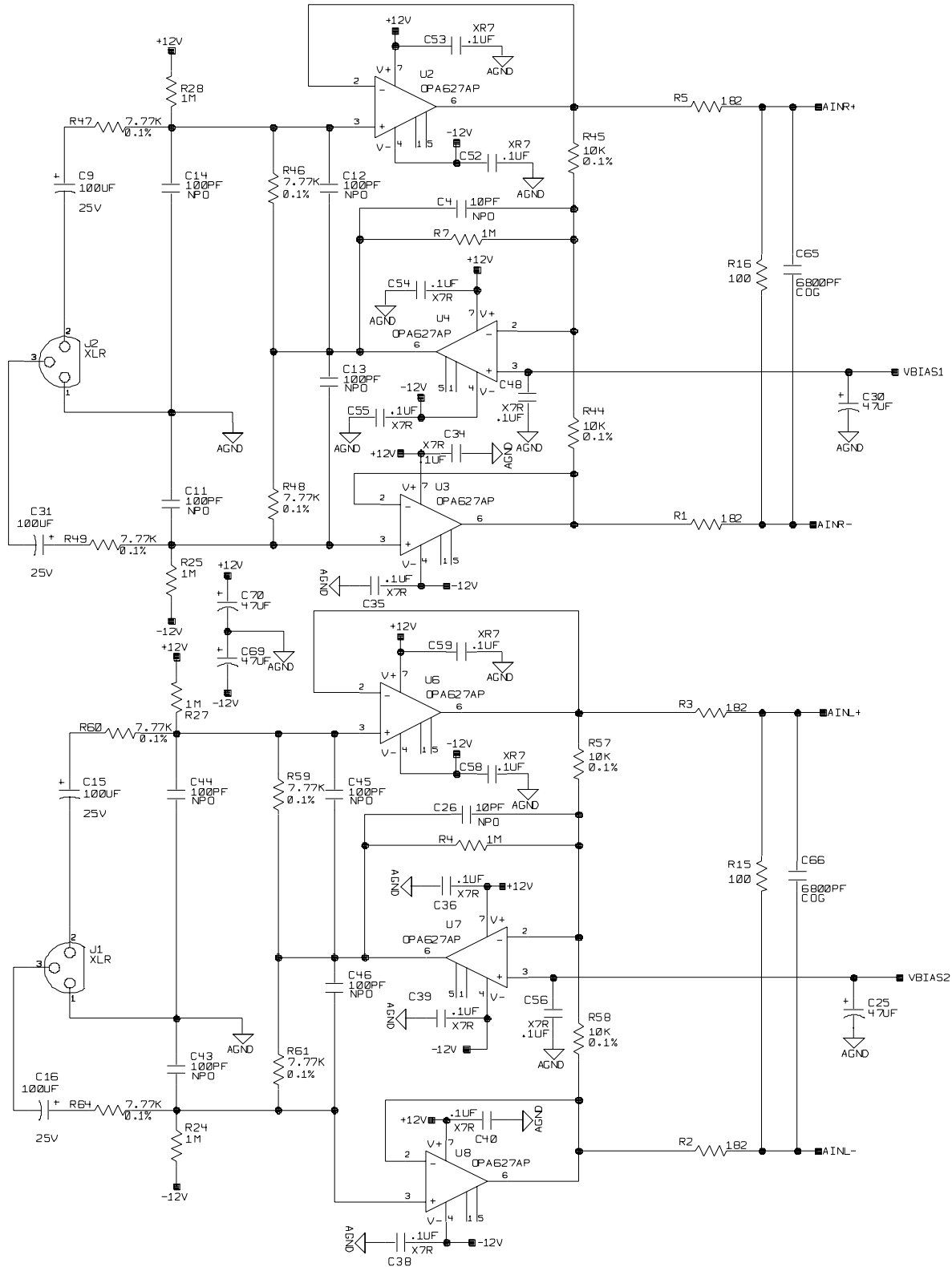


Figure 4. Analog Input Buffer

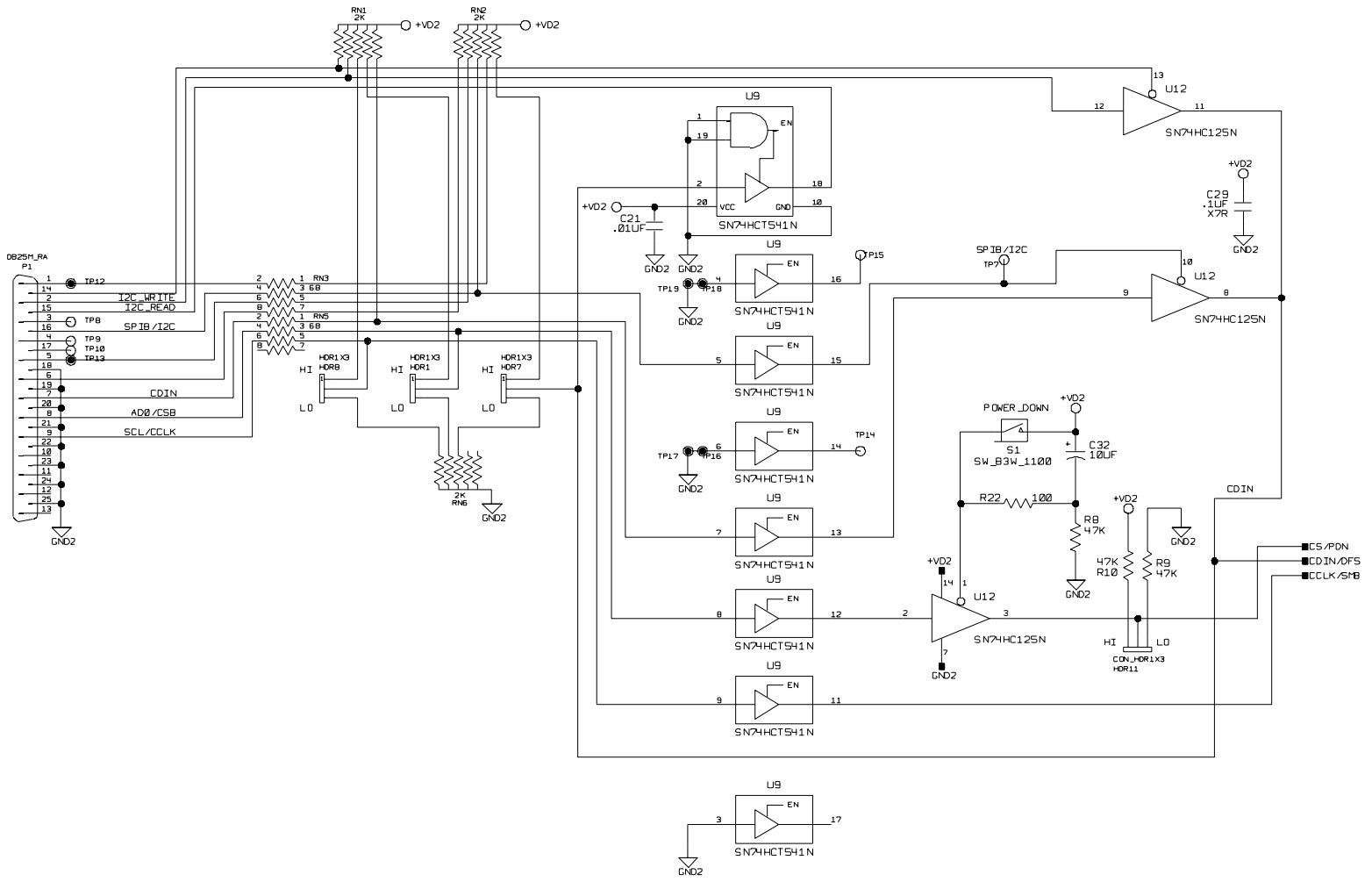


Figure 5. P.C. Parallel Interface

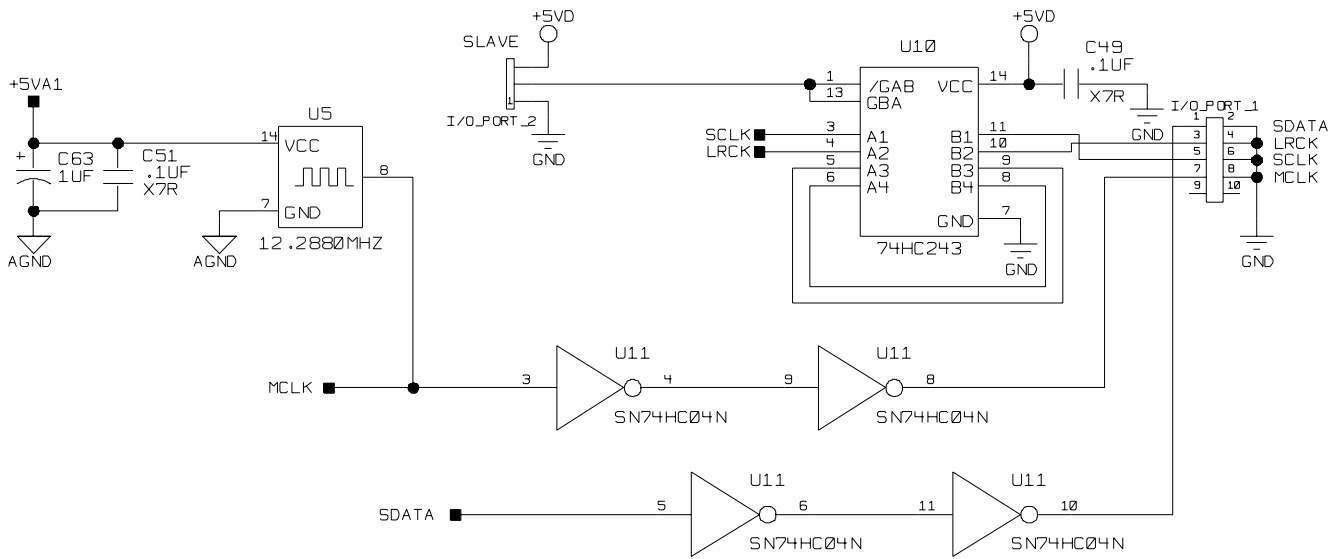


Figure 6. I/O Interface for Clocks & Data

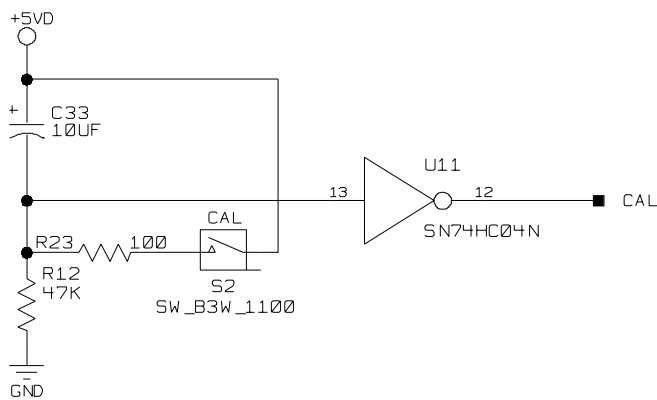


Figure 7. CAL Circuitry

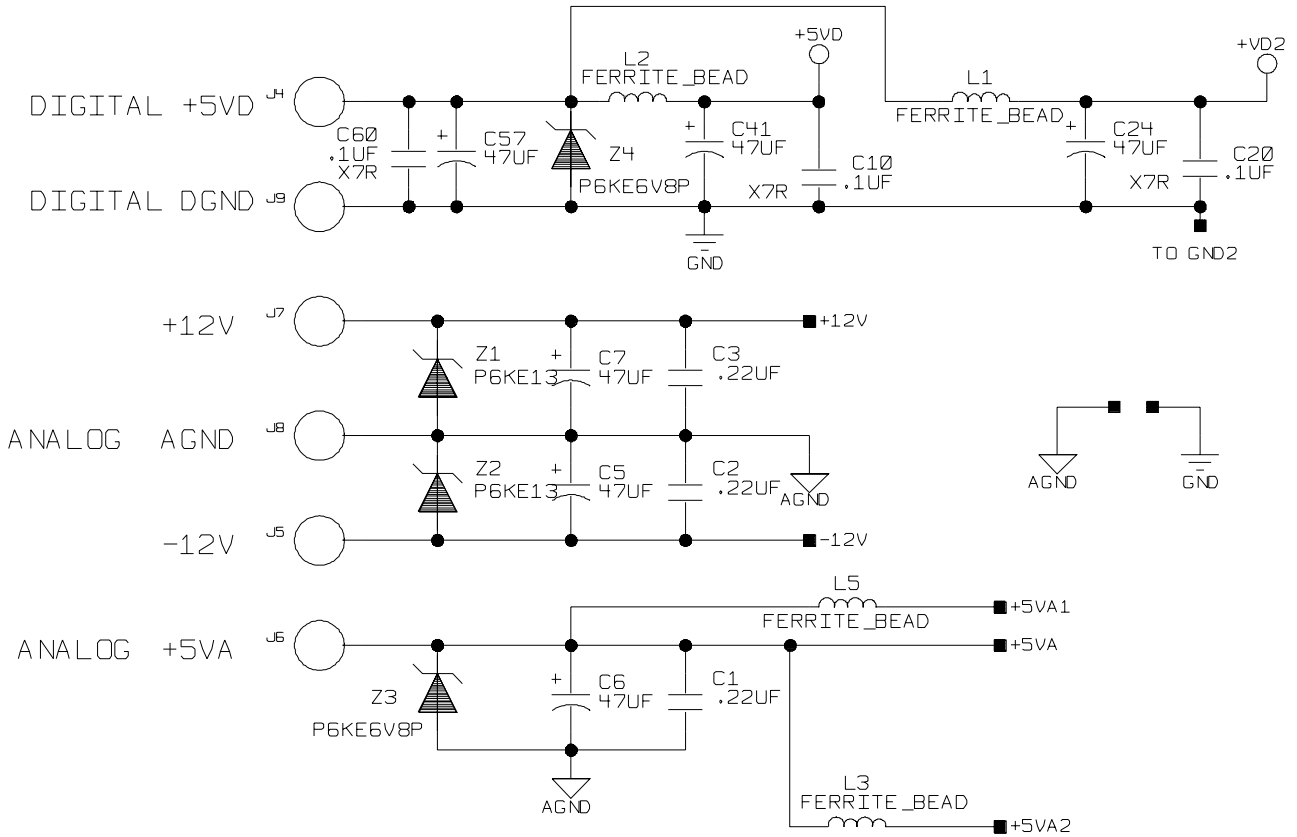
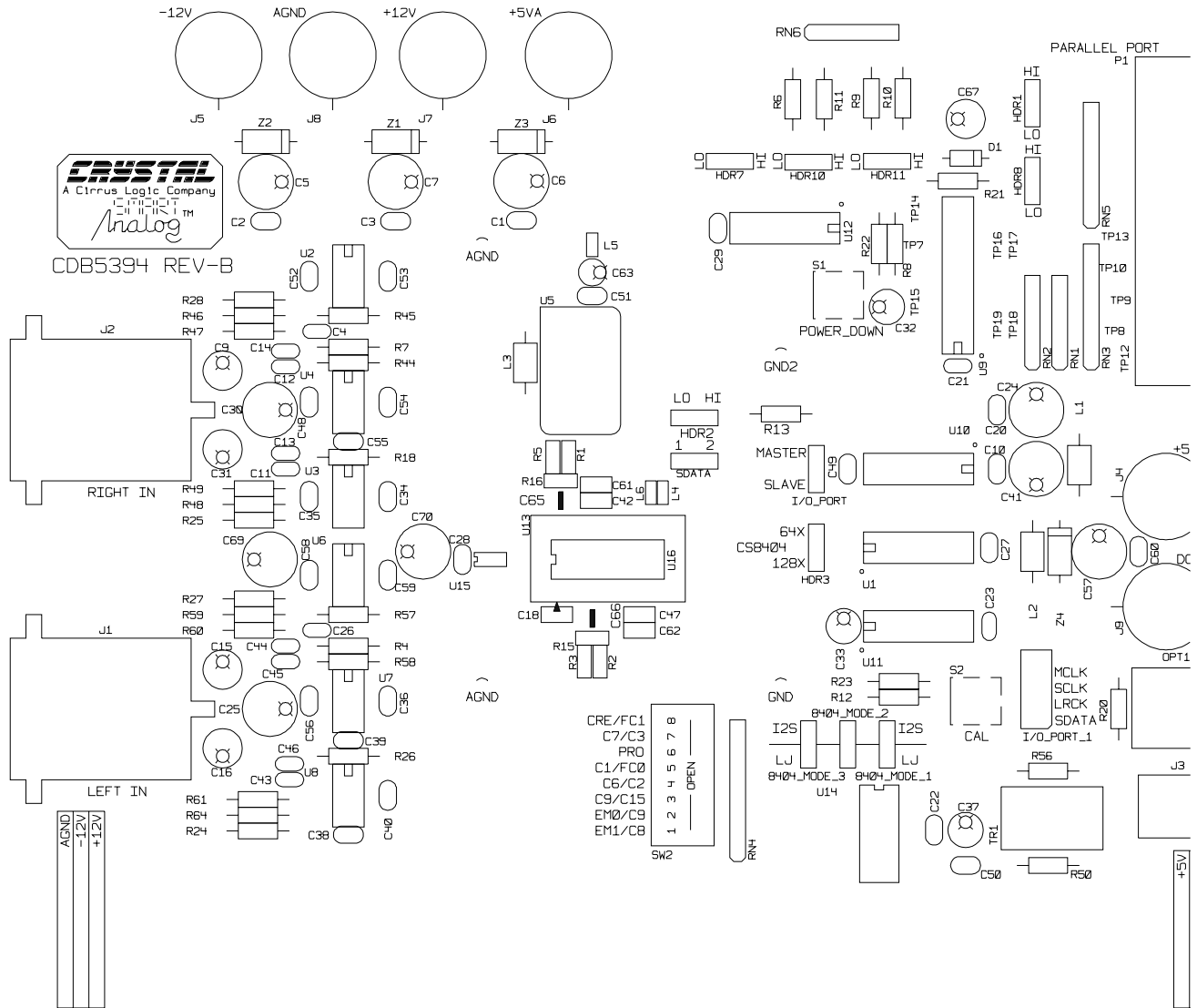
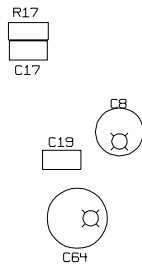


Figure 8. Power Supply & Reset Circuitry



SILKSCREEN - TOP

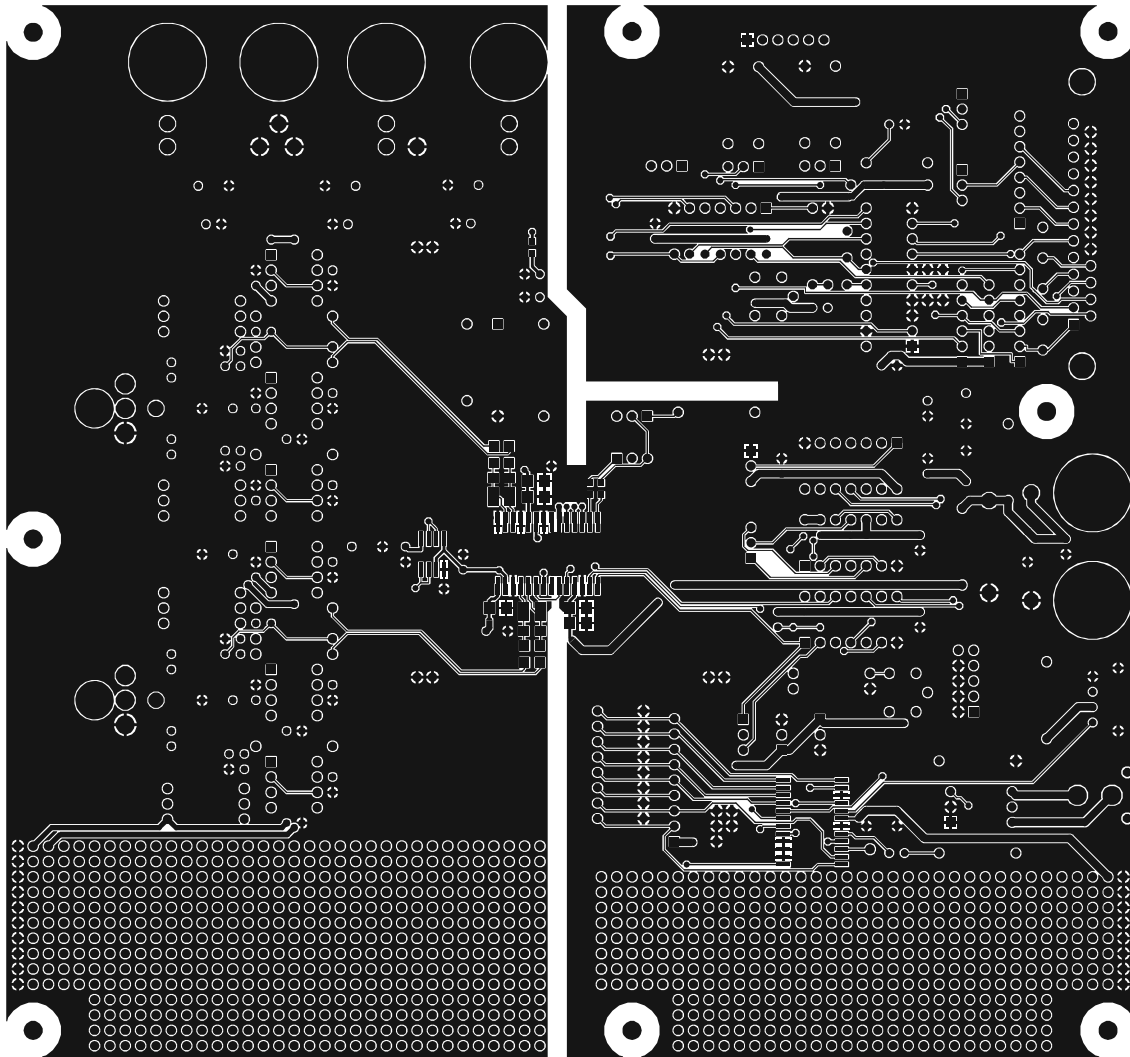
Figure 9. CDB5394 and CDB5396/7 Component Silkscreen Side (top)



SILKSCREEN - BOTTOM

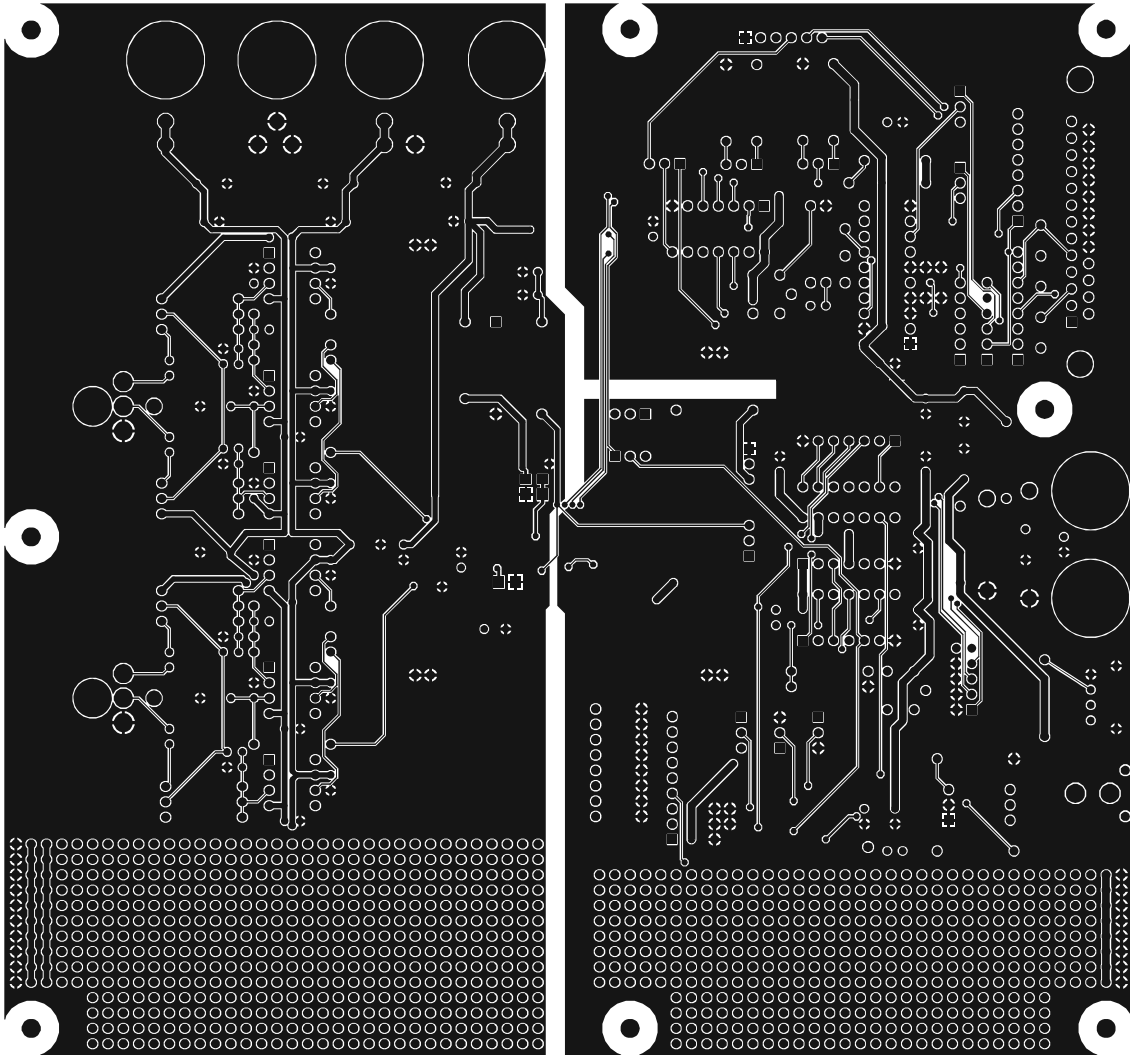


Figure 10. CDB5394 and CDB5396/7 Component Silkscreen Side (bottom)



TOP SIDE

Figure 11. CDB5394 and CDB5396/7 Component Copper Side (top)



BOTTOM SIDE

Figure 12. CDB5394 and CDB5396/7 Component Copper Side (bottom)

• **Notes** •



Smart *Analog*TM is a Trademark of Crystal Semiconductor Corporation