

LPV7215

Micropower, CMOS Input, RRIO, 1.8V, Push-Pull Output Comparator

General Description

The LPV7215 is an ultra low-power comparator with a typical power supply current of 580 nA. It has the best-in-class power supply current versus propagation delay performance available among National's low-power comparators. The propagation delay is as low as 4.5 microseconds with 100 mV overdrive at 1.8V supply.

Designed to operate over a wide range of supply voltages, from 1.8V to 5.5V, with guaranteed operation at 1.8V, 2.7V and 5.0V, the LPV7215 is ideal for use in a variety of battery-powered applications. With rail-to-rail common mode voltage range, the LPV7215 is well suited for single-supply operation.

Featuring a push-pull output stage, the LPV7215 allows for operation with absolute minimum power consumption when driving any capacitive or resistive load.

Available in a choice of space-saving packages, the LPV7215 is ideal for use in handheld electronics and mobile phone applications. The LPV7215 is manufactured with National's advanced VIP50 process.

Features

(For $V^+ = 1.8V$, typical unless otherwise noted)

- Ultra low power consumption 580 nA
- Wide supply voltage range 1.8V to 5.5V
- Propagation delay 4.5 μ s
- Push-Pull output current drive @ 5V 19 mA
- Temperature range -40°C to 85°C
- Rail-to-rail input
- Tiny SOT23-5 and SC70-5 packages

Applications

- RC timers
- Window detectors
- IR receiver
- Multivibrators
- Alarm and monitoring circuits

Typical Application

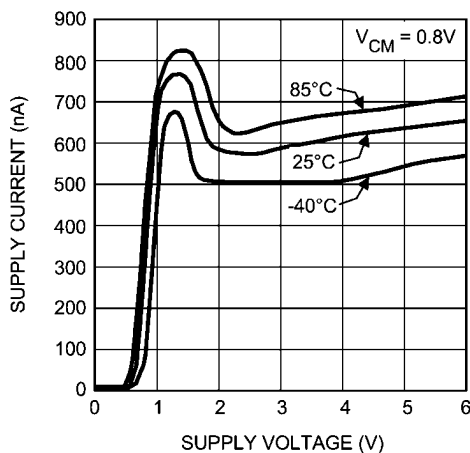

Supply Current vs. Supply Voltage

20123605

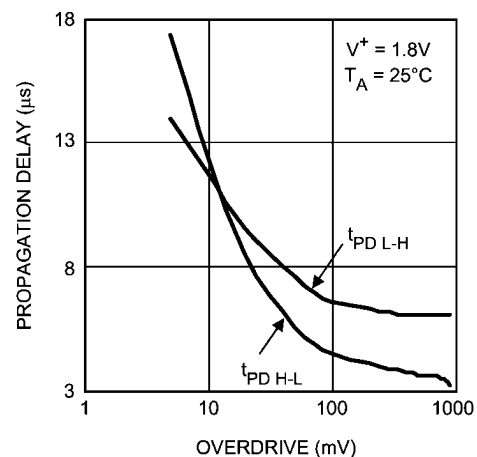

Propagation Delay vs. Overdrive

20123602

Absolute Maximum Ratings (Note 1)

If Military/Aerospace specified devices are required, please contact the National Semiconductor Sales Office/Distributors for availability and specifications.

ESD Tolerance (Note 2)

| | |
|---|--|
| Human Body Model | 2000V |
| Machine Model | 200V |
| V _{IN} Differential | ±2.5V |
| Supply Voltage (V ⁺ - V ⁻) | 6V |
| Voltage at Input/Output pins | V ⁺ +0.3V, V ⁻ -0.3V |
| Storage Temperature Range | -65°C to +150°C |
| Junction Temperature (Note 3) | +150°C |

Soldering Information

| | |
|------------------------------------|-------|
| Infrared or Convection (20 sec) | 235°C |
| Wave Soldering Lead Temp. (10 sec) | 260°C |

Operating Ratings (Note 1)

| | |
|---|---------------|
| Temperature Range (Note 3) | -40°C to 85°C |
| Supply Voltage (V ⁺ - V ⁻) | 1.8V to 5.5V |
| Package Thermal Resistance (θ _{JA} (Note 3)) | |
| 5-Pin SC70 | 456°C/W |
| 5-Pin SOT23 | 234°C/W |

1.8V Electrical Characteristics (Note 8)

Unless otherwise specified, all limits are guaranteed for T_A = 25°C, V⁺ = 1.8V, V⁻ = 0V, and V_{CM} = V⁺/2, V_O = V⁻. **Boldface** limits apply at the temperature extremes.

| Symbol | Parameter | Conditions | Min (Note 5) | Typ (Note 4) | Max (Note 5) | Units | |
|-------------------|---------------------------------|---|------------------------|--------------|--------------------|---------------------|----|
| I _S | Supply Current | V _{CM} = 0.3V | | 580 | 750 825 | nA | |
| | | V _{CM} = 1.5V | | 790 | 980 1050 | | |
| V _{OS} | Input Offset Voltage | SC70 Package | V _{CM} = 0V | | ±0.3 | ±2.8 ±3.5 | mV |
| | | | V _{CM} = 1.8V | | ±0.4 | ±2.2 ±2.9 | |
| | | SOT23 Package | V _{CM} = 0V | | | ±3.2 ±3.9 | |
| | | | V _{CM} = 1.8V | | | ±2.5 ±3.2 | |
| TCV _{OS} | Input Offset Average Drift | (Note 7) | | ±1 | | µV/C | |
| I _B | Input Bias Current (Note 6) | V _{CM} = 1.6V | | -40 | | fA | |
| I _{OS} | Input Offset Current | | | 10 | | fA | |
| CMRR | Common Mode Rejection Ratio | V _{CM} Stepped from 0V to 0.7V | 66 65 | 88 | | dB | |
| | | V _{CM} Stepped from 1.2V to 1.8V | 68 65 | 87 | | | |
| | | V _{CM} Stepped from 0V to 1.8V | 56 55 | 77 | | | |
| PSRR | Power Supply Rejection Ratio | V ⁺ = 1.8V to 5.5V, V _{CM} = 0V | 66 63 | 82 | | dB | |
| CMVR | Input Common-Mode Voltage Range | CMRR ≥ 55 dB | -0.1 | | 1.9 | V | |
| A _V | Voltage Gain | | | 120 | | dB | |
| V _O | Output Swing High | I _O = 500 µA | 1.63 1.60 | 1.69 | | V | |
| | | I _O = 1 mA | 1.46 1.40 | 1.60 | | | |
| | Output Swing Low | I _O = -500 µA | | | 88 | 180 210 | mV |
| | | I _O = -1 mA | | | 180 | 310 370 | |

| Symbol | Parameter | Conditions | Min (Note 5) | Typ (Note 4) | Max (Note 5) | Units |
|------------|------------------------------------|---|---------------------|--------------------------------|-----------------|---------|
| I_{OUT} | Output Current | Source $V_O = V+/2$ | 1.75 1.5 | 2.26 | | mA |
| | | Sink $V_O = V+/2$ | 2.35 1.75 | 3.1 | | |
| | Propagation Delay (High to Low) | Overdrive = 10 mV | | 13 | | μ s |
| | | Overdrive = 100 mV | | 4.5 6.5 8 | | |
| | Propagation Delay (Low to High) | Overdrive = 10 mV | | 12.5 | | μ s |
| | | Overdrive = 100 mV | | 6.6 9 10.5 | | |
| t_{rise} | Rise Time | Overdrive = 10 mV $C_L = 30$ pF, $R_L = 1$ M Ω | | 80 | | ns |
| | | Overdrive = 100 mV $C_L = 30$ pF, $R_L = 1$ M Ω | | 75 | | |
| t_{fall} | Fall Time | Overdrive = 10 mV $C_L = 30$ pF, $R_L = 1$ M Ω | | 70 | | ns |
| | | Overdrive = 100 mV $C_L = 30$ pF, $R_L = 1$ M Ω | | 65 | | |

2.7V Electrical Characteristics (Note 8)

Unless otherwise specified, all limits are guaranteed for $T_A = 25^\circ\text{C}$, $V^+ = 2.7\text{V}$, $V^- = 0\text{V}$, and $V_{CM} = V+/2$, $V_O = V^-$. **Boldface** limits apply at the temperature extremes.

| Symbol | Parameter | Conditions | Min (Note 5) | Typ (Note 4) | Max (Note 5) | Units | |
|------------|---------------------------------|---|------------------------|-----------------|---------------------|--|----|
| I_S | Supply Current | $V_{CM} = 0.3\text{V}$ | | 605 | 780 860 | nA | |
| | | $V_{CM} = 2.4\text{V}$ | | 815 | 1010 1090 | | |
| V_{OS} | Input Offset Voltage | SC70 Package | $V_{CM} = 0\text{V}$ | | ± 0.3 | ± 2.8 ± 3.5 | mV |
| | | | $V_{CM} = 2.7\text{V}$ | | ± 0.3 | ± 2.2 ± 2.9 | |
| | | SOT23 Package | $V_{CM} = 0\text{V}$ | | | ± 3.2 ± 3.9 | |
| | | | $V_{CM} = 2.7\text{V}$ | | | ± 2.5 ± 3.2 | |
| TCV_{OS} | Input Offset Average Drift | (Note 7) | | ± 1 | | $\mu\text{V}/\text{C}$ | |
| I_B | Input Bias Current (Note 6) | $V_{CM} = 1.8\text{V}$ | | -40 | | fA | |
| I_{OS} | Input Offset Current | | | 20 | | fA | |
| CMRR | Common Mode Rejection Ratio | V_{CM} Stepped from 0V to 1.6V | 72 69 | 90 | | dB | |
| | | V_{CM} Stepped from 2.1V to 2.7V | 71 66 | 94 | | | |
| | | V_{CM} Stepped from 0V to 2.7V | 59 58 | 80 | | | |
| PSRR | Power Supply Rejection Ratio | $V^+ = 1.8\text{V}$ to 5.5V, $V_{CM} = 0\text{V}$ | 66 63 | 82 | | dB | |
| CMVR | Input Common-Mode Voltage Range | CMRR ≥ 55 dB | -0.1 | | 2.8 | V | |
| A_V | Voltage Gain | | | 120 | | dB | |

| Symbol | Parameter | Conditions | Min (Note 5) | Typ (Note 4) | Max (Note 5) | Units |
|-------------------|------------------------------------|---|---------------------|-----------------|-------------------|-------|
| V _O | Output Swing High | I _O = 500 μA | 2.57 2.55 | 2.62 | | V |
| | | I _O = 1 mA | 2.47 2.43 | 2.53 | | |
| | Output Swing Low | I _O = -500 μA | | 60 | 130 160 | mV |
| | | I _O = -1 mA | | 120 | 250 300 | |
| I _{OUT} | Output Current | Source V _O = V ⁺ /2 | 4.5 3.8 | 5.7 | | mA |
| | | Sink V _O = V ⁺ /2 | 5.6 4 | 7.5 | | |
| | Propagation Delay (High to Low) | Overdrive = 10 mV | | 14.5 | | μs |
| | | Overdrive = 100 mV | | 5.8 | 8.5 9.5 | |
| | Propagation Delay (Low to High) | Overdrive = 10 mV | | 15 | | |
| | | Overdrive = 100 mV | | 7.5 | 10 11 | |
| t _{rise} | Rise Time | Overdrive = 10 mV C _L = 30 pF, R _L = 1 MΩ | | 90 | | ns |
| | | Overdrive = 100 mV C _L = 30 pF, R _L = 1 MΩ | | 85 | | |
| t _{fall} | Fall Time | Overdrive = 10 mV C _L = 30 pF, R _L = 1 MΩ | | 85 | | ns |
| | | Overdrive = 100 mV C _L = 30 pF, R _L = 1 MΩ | | 75 | | |

5V Electrical Characteristics (Note 8)

Unless otherwise specified, all limits are guaranteed for T_A = 25°C, V⁺ = 5V, V⁻ = 0V, and V_{CM} = V⁺/2, V_O = V⁻. **Boldface** limits apply at the temperature extremes.

| Symbol | Parameter | Conditions | Min (Note 5) | Typ (Note 4) | Max (Note 5) | Units | |
|-------------------|-----------------------------|------------------------|----------------------|-----------------|---------------------|---------------------|----|
| I _S | Supply Current | V _{CM} = 0.3V | | 612 | 790 970 | nA | |
| | | V _{CM} = 4.7V | | 825 | 1030 1230 | | |
| V _{OS} | Input Offset Voltage | SC70 Package | V _{CM} = 0V | | ±0.3 | ±3 ±3.7 | mV |
| | | | V _{CM} = 5V | | | ±2.3 ±3.0 | |
| | | SOT23 Package | V _{CM} = 0V | | | ±3.4 ±4.1 | |
| | | | V _{CM} = 5V | | | ±2.6 ±3.3 | |
| TCV _{OS} | Input Offset Average Drift | (Note 7) | | ±1 | | μV/C | |
| I _B | Input Bias Current (Note 6) | V _{CM} = 4.5V | | -400 | | fA | |
| I _{OS} | Input Offset Current | | | 20 | | fA | |

| Symbol | Parameter | Conditions | Min (Note 5) | Typ (Note 4) | Max (Note 5) | Units |
|------------|------------------------------------|---|---------------------|-----------------|--------------------------------|---------|
| CMRR | Common Mode Rejection Ratio | V_{CM} Stepped from 0V to 3.9V | 72 69 | 98 | | dB |
| | | V_{CM} Stepped from 4.4V to 5V | 73 70 | 92 | | |
| | | V_{CM} Stepped from 0V to 5V | 64 63 | 82 | | |
| PSRR | Power Supply Rejection Ratio | $V^+ = 1.8V$ to 5.5V, $V_{CM} = 0V$ | 66 63 | 82 | | dB |
| CMVR | Input Common-Mode Voltage Range | CMRR \geq 55 dB | -0.1 | | 5.1 | V |
| A_V | Voltage Gain | | | 120 | | dB |
| V_O | Output Swing High | $I_O = 500 \mu A$ | 4.9 4.88 | 4.94 | | V |
| | | $I_O = 1 \text{ mA}$ | 4.82 4.79 | 4.89 | | |
| | Output Swing Low | $I_O = -500 \mu A$ | | | 43 110 | mV |
| | | $I_O = -1 \text{ mA}$ | | | 88 170 200 | |
| I_{OUT} | Output Current | Source $V_O = V^+/2$ | 13.0 9.0 | 17 | | mA |
| | | Sink $V_O = V^+/2$ | 14.5 10.5 | 19 | | |
| | Propagation Delay (High to Low) | Overdrive = 10 mV | | 18 | | μs |
| | | Overdrive = 100 mV | | 7.7 | 13.5 15 | |
| | Propagation Delay (Low to High) | Overdrive = 10 mV | | 30 | | μs |
| | | Overdrive = 100 mV | | 12 | 15 17.5 | |
| t_{rise} | Rise Time | Overdrive = 10 mV $C_L = 30 \text{ pF}$, $R_L = 1 \text{ M}\Omega$ | | 100 | | ns |
| | | Overdrive = 100 mV $C_L = 30 \text{ pF}$, $R_L = 1 \text{ M}\Omega$ | | 100 | | |
| t_{fall} | Fall Time | Overdrive = 10 mV $C_L = 30 \text{ pF}$, $R_L = 1 \text{ M}\Omega$ | | 115 | | ns |
| | | Overdrive = 100 mV $C_L = 30 \text{ pF}$, $R_L = 1 \text{ M}\Omega$ | | 95 | | |
| | | $C_L = 30 \text{ pF}$, $R_L = 1 \text{ M}\Omega$ | | | | |

Note 1: Absolute Maximum Ratings indicate limits beyond which damage to the device may occur. Operating Ratings indicate conditions for which the device is intended to be functional, but specific performance is not guaranteed. For guaranteed specifications and the test conditions, see the Electrical Characteristics Tables.

Note 2: Human Body Model, applicable std. MIL-STD-883, Method 3015.7. Machine Model, applicable std. JESD22-A115-A (ESD MM std. of JEDEC) Field-Induced Charge-Device Model, applicable std. JESD22-C101-C (ESD FICDM std. of JEDEC).

Note 3: The maximum power dissipation is a function of $T_{J(MAX)}$, θ_{JA} . The maximum allowable power dissipation at any ambient temperature is $P_D = (T_{J(MAX)} - T_A) / \theta_{JA}$. All numbers apply for packages soldered directly onto a PC board.

Note 4: Typical values represent the most likely parametric norm as determined at the time of characterization. Actual typical values may vary over time and will also depend on the application and configuration. The typical values are not tested and are not guaranteed on shipped production material.

Note 5: Limits are 100% production tested at 25°C. Limits over the operating temperature range are guaranteed through correlations using statistical quality control (SQC) method.

Note 6: Positive current corresponds to current flowing into the device.

Note 7: Offset voltage average drift determined by dividing the change in V_{OS} at temperature extremes into the total temperature change.

Note 8: Electrical table values apply only for factory testing conditions at the temperature indicated. Factory testing conditions result in very limited self-heating of the device.

Connection Diagram

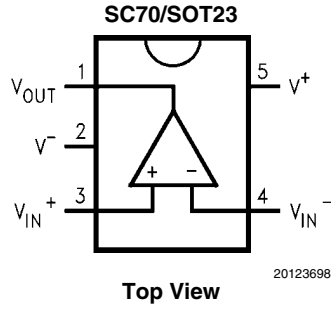

Ordering Information

| Package | Part Number | Package Marking | Transport Media | NSC Drawing |
|--------------|-------------|-----------------|------------------------|-------------|
| 5-Pin SOT-23 | LPV7215MF | C30A | 1k Units Tape and Reel | MF05A |
| | LPV7215MFX | | 3k Units Tape and Reel | |
| 5-Pin SC70 | LPV7215MG | C37 | 1k Units Tape and Reel | MAA05A |
| | LPV7215MGX | | 3k Units Tape and Reel | |

Simplified Schematic Diagram

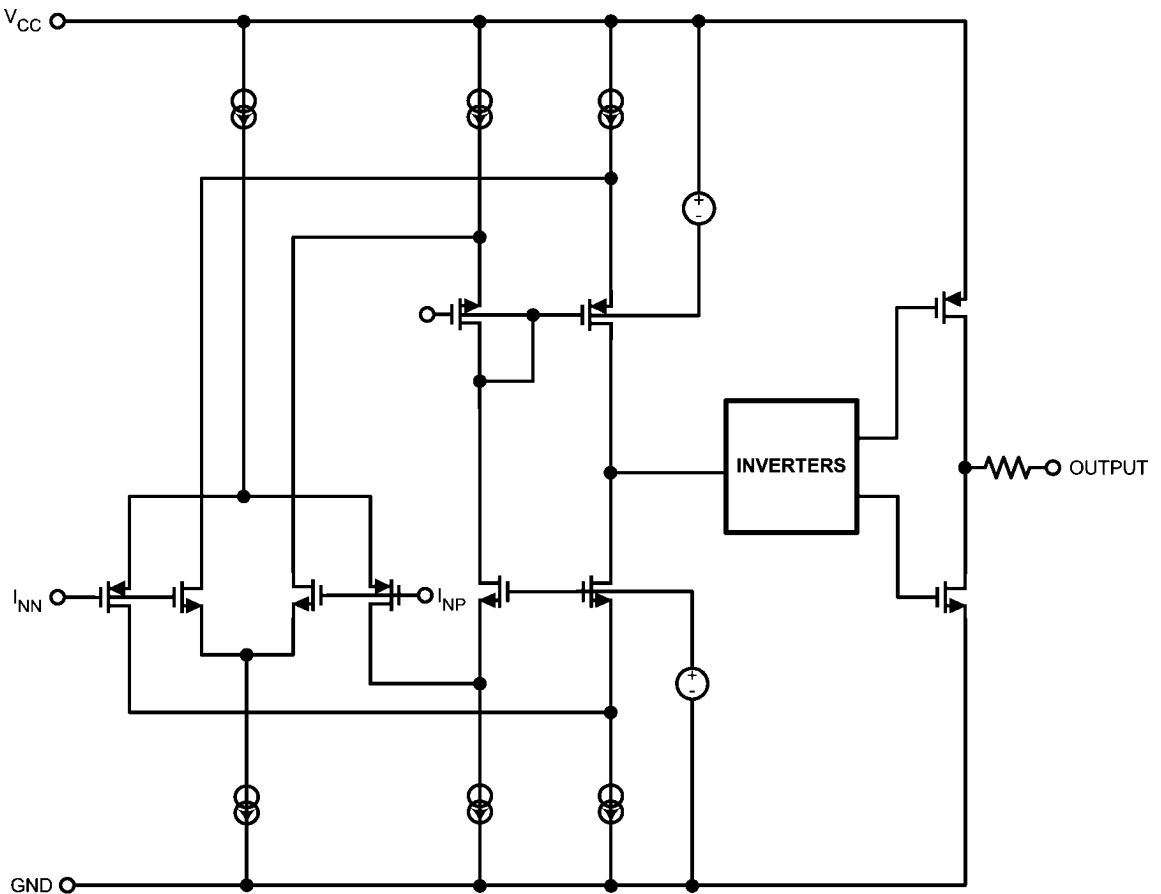

Typical Performance Characteristics At $T_J = 25^\circ\text{C}$. Unless otherwise specified.

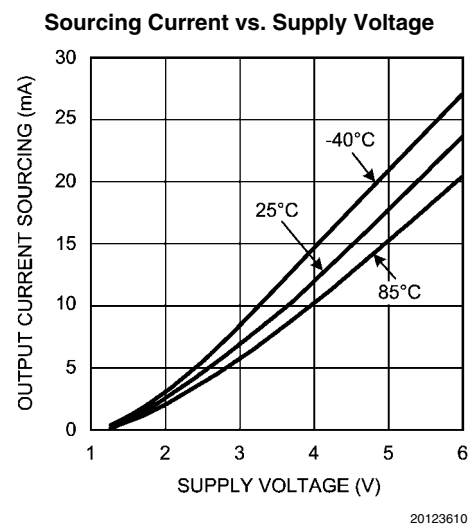
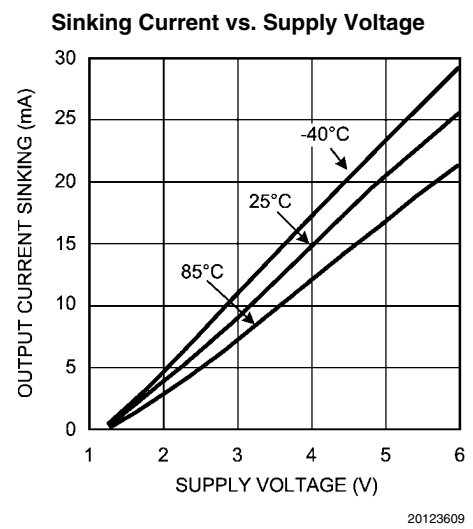
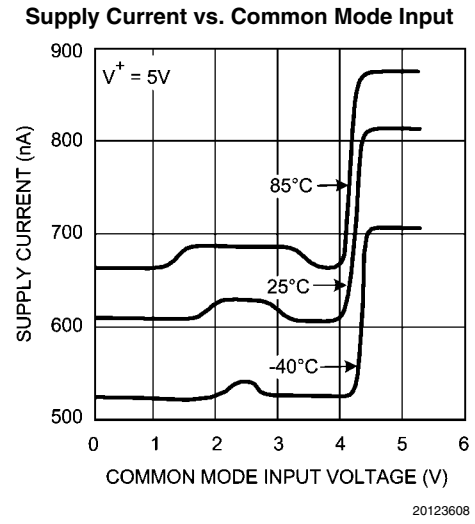
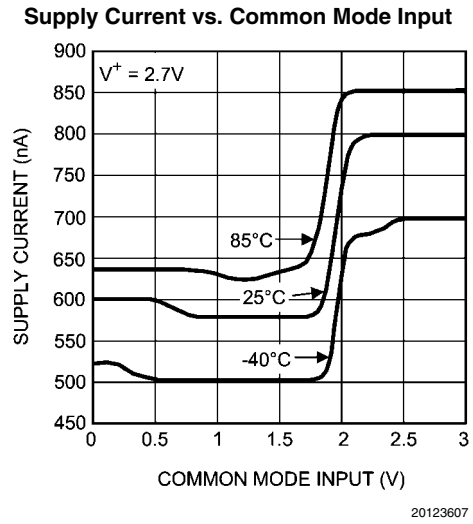
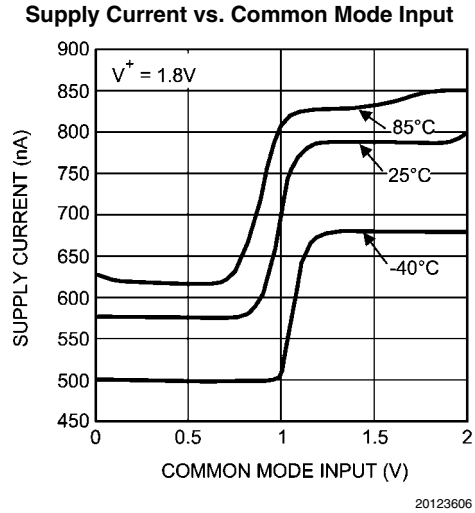
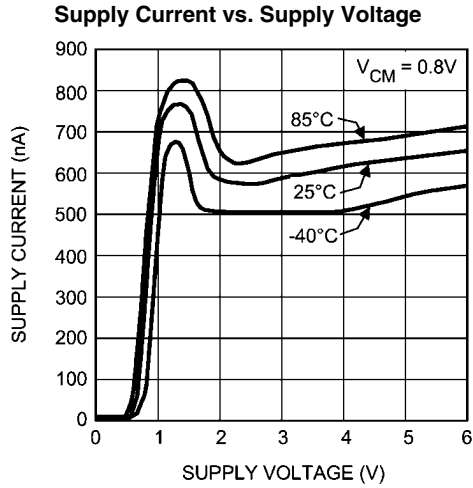

Propagation Delay vs. Supply Voltage

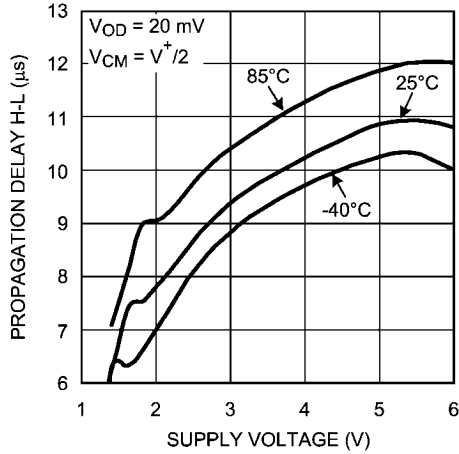

20123611

Propagation Delay vs. Supply Voltage

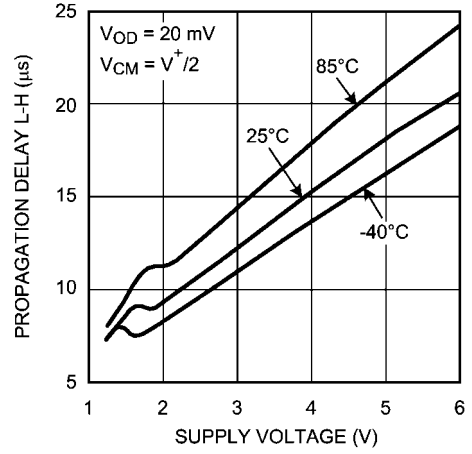

20123612

Propagation Delay vs. Overdrive

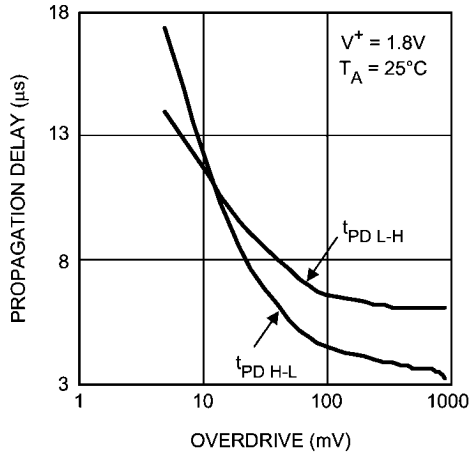

20123602

Propagation Delay vs. Overdrive

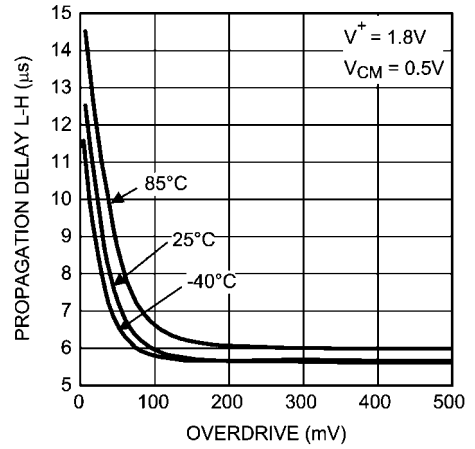

20123613

Propagation Delay vs. Overdrive

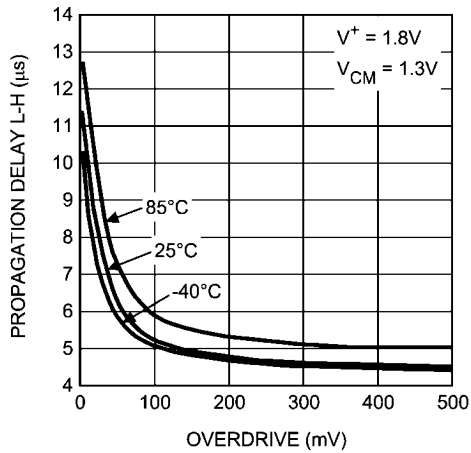

20123614

Propagation Delay vs. Overdrive

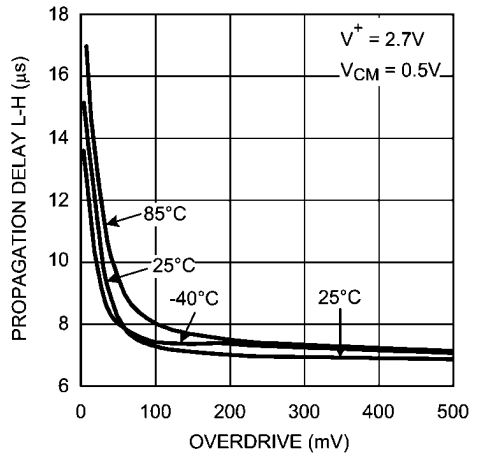

20123622

Propagation Delay vs. Overdrive

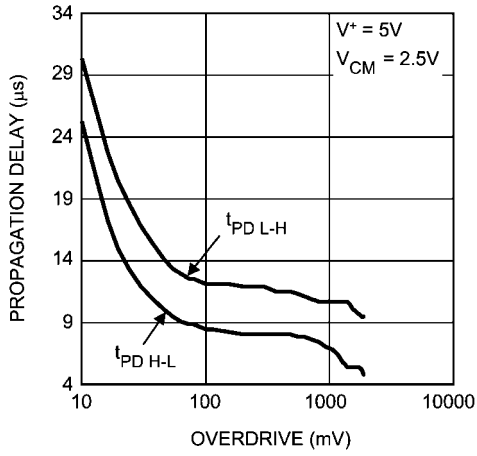

20123603

Propagation Delay vs. Overdrive

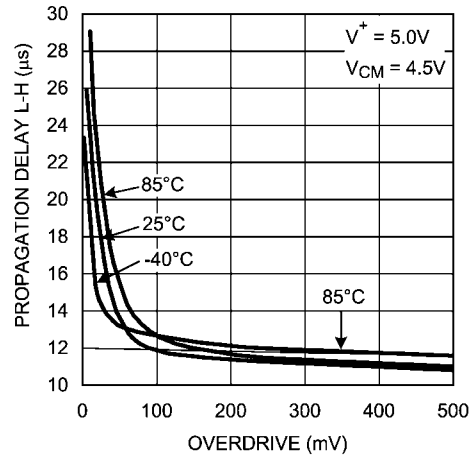

20123615

Propagation Delay vs. Overdrive

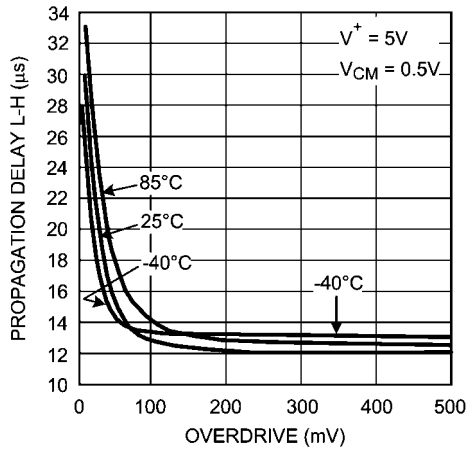

20123623

Propagation Delay vs. Resistive Load

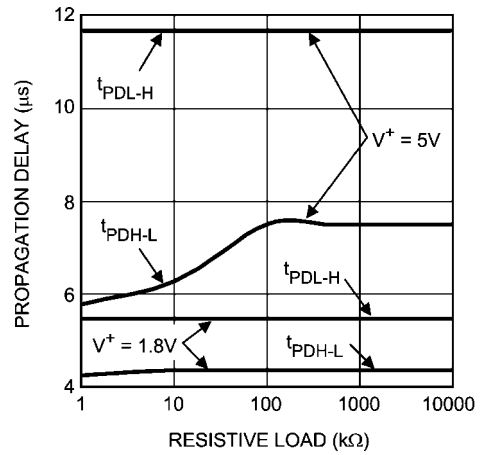

20123616

I_{BIAS} vs. V_{CM}

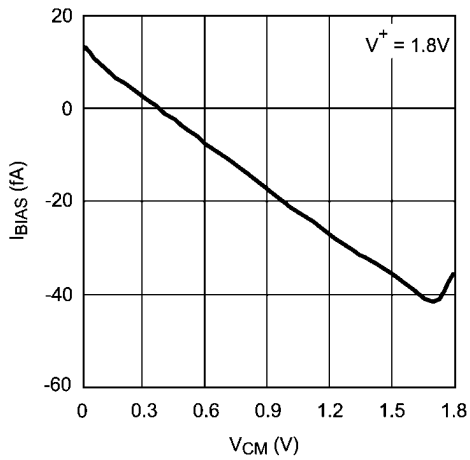

20123620

I_{BIAS} vs. V_{CM}

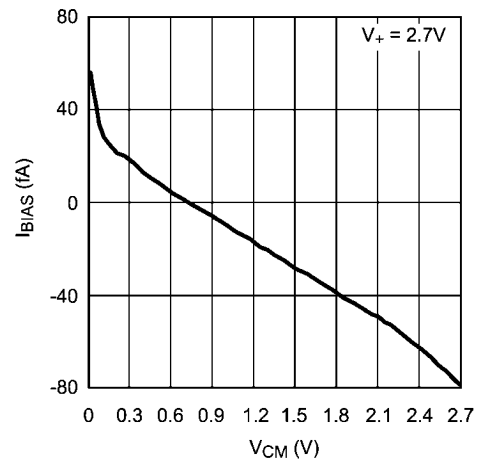

20123618

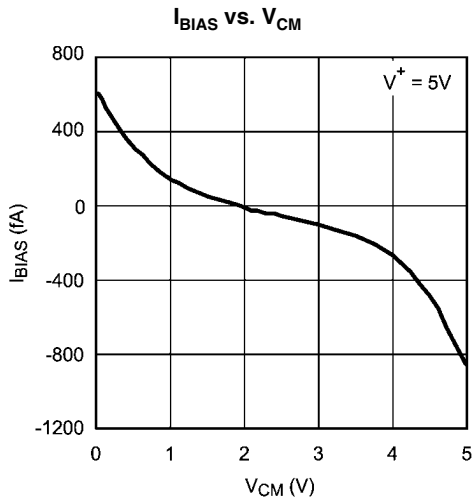

20123619

Propagation Delay vs. Common Mode Input

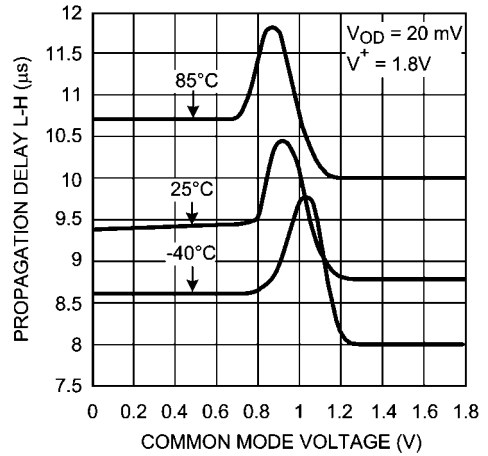

20123624

Propagation Delay vs. Common Mode Input

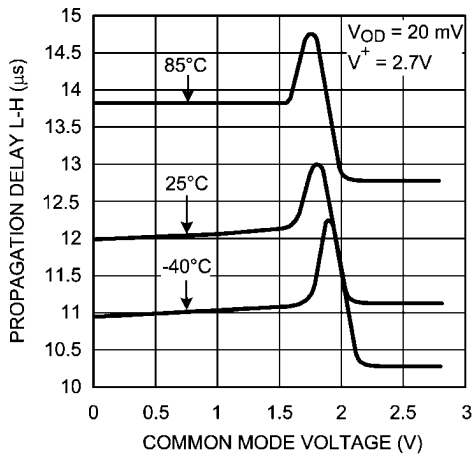

20123625

Propagation Delay vs. Common Mode Input

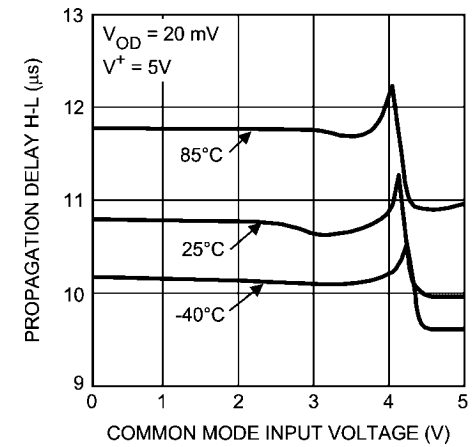

20123617

Propagation Delay vs. Common Mode Input

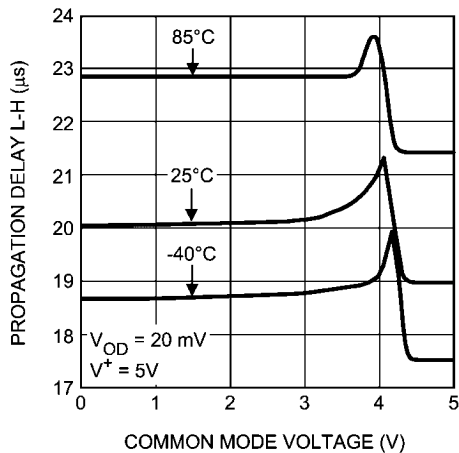

20123626

Offset Voltage vs. Common Mode Input

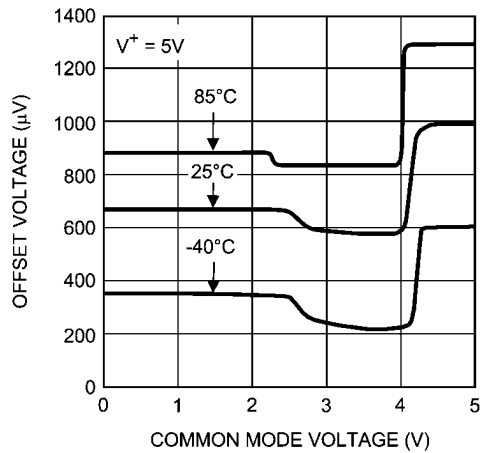

20123644

Application Information

Low supply current and fast propagation delay distinguish the LPV7215 from other low power comparators.

INPUT STAGE

The LPV7215 has rail-to-rail input common mode voltage range. It can operate at any differential input voltage within this limit as long as the differential voltage is greater than zero. A differential input of zero volts may result in oscillation.

The differential input stage of the comparator is a pair of PMOS and NMOS transistors, therefore, no current flows into the device. The input bias current measured is the leakage current in the MOS transistors and input protection diodes. This low bias current allows the comparator to interface with a variety of circuitry and devices with minimal concern about matching the input resistances.

The input to the comparator is protected from excessive voltage by internal ESD diodes connected to both supply rails. This protects the circuit from both ESD events, as well as signals that significantly exceed the supply voltages. When this occurs the ESD protection diodes will become forward biased and will draw current into these structures, resulting in no input current to the terminals of the comparator. Until this occurs, there is essentially no input current to the diodes. As a result, placing a large resistor in series with an input that may be exposed to large voltages, will limit the input current but have no other noticeable effect.

OUTPUT STAGE

The LPV7215 has a MOS push-pull rail-to-rail output stage. The push-pull transistor configuration of the output keeps the total system power consumption to a minimum. The only current consumed by the LPV7215 is the less than 1 μA supply current and the current going directly into the load. No power is wasted through the pull-up resistor when the output is low. The output stage is specifically designed with deadtime between the time when one transistor is turned off and the other is turned on (break-before-make) in order to minimize shoot through currents. The internal logic controls the break-before-make timing of the output transistors. The break-before-make delay varies with temperature and power condition.

OUTPUT CURRENT

Even though the LPV7215 uses less than 1 μA supply current, the outputs are able to drive very large currents. The LPV7215 can source up to 17 mA and can sink up to 19 mA, when operated at 5V supply. This large current handling capability allows driving heavy loads directly.

RESPONSE TIME

Depending upon the amount of overdrive, the propagation delay will be typically 6 to 30 μs . The curves showing propagation delay vs. overdrive in the “Typical Characteristics” section shows the delay time when the input is preset with 100 mV across the inputs and then is driven the other way by 10 mV to 500 mV.

The output signal can show a step during switching depending on the load. A fast RC time constant due to both small capacitive and resistive loads will show a significant step in the output signal. A slow RC time constant due to either a large resistive or capacitive load will have a clipped corner on the output signal. The step is observed more prominently during a falling transition from high to low.

The plot in *Figure 1* shows the output for single 5V supply with a 100 k Ω resistor. The step is at 1.3V.

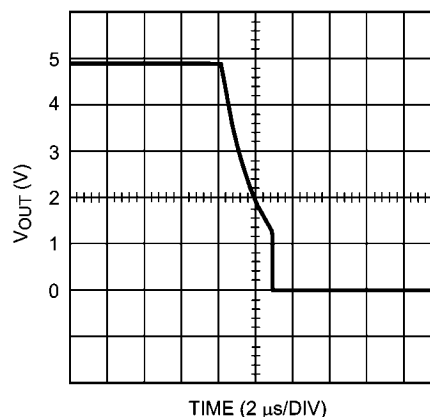

20123627

FIGURE 1. Output Signal without Cap Load

The plot in *Figure 2* shows the output signal when a 20 pF capacitor is added as a load. The step is at about 2.5V.

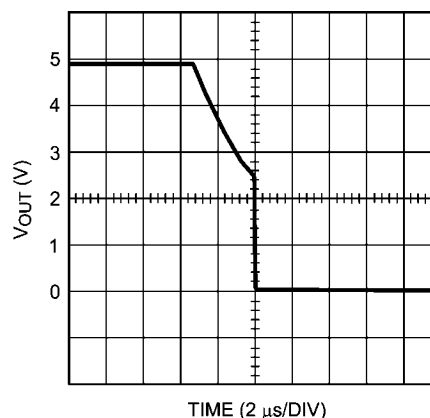

20123628

FIGURE 2. Output Signal with 20 pF Load

CAPACITIVE AND RESISTIVE LOADS

The propagation delay is not affected by capacitive loads at the output of the LPV7215. However, resistive loads slightly effect the propagation delay on the falling edge by a reduction of almost 2 μs depending on the load resistance value.

NOISE

Most comparators have rather low gain. This allows the output to spend time between high and low when the input signal changes slowly. The result is the output may oscillate between high and low when the differential input is near zero. The exceptionally high gain of this comparator, 120 dB, eliminates this problem. Less than 1 μV of change on the input will drive the output from one rail to the other rail. If the input signal is noisy, the output cannot ignore the noise unless some hysteresis is provided by positive feedback. (See section on adding hysteresis.)

LAYOUT/BYPASS CAPACITORS

Proper grounding and the use of a ground plane will help to ensure the specified performance of the LPV7215. Minimizing trace lengths, reducing unwanted parasitic capacitance and using surface-mount components will also help.

Comparators are very sensitive to input noise. To minimize supply noise, power supplies should be capacitively decoupled by a 0.01 μF ceramic capacitor in parallel with a 10 μF electrolytic capacitor.

HYSTERESIS

In order to improve propagation delay when low overdrive is needed hysteresis can be added.

INVERTING COMPARATOR WITH HYSTERESIS

The inverting comparator with hysteresis requires a three resistor network that is referenced to the supply voltage V+ of the comparator as shown in Figure 3. When VIN at the inverting input is less than VA, the voltage at the non-inverting node of the comparator (VIN < VA), the output voltage is high (for simplicity assume VO switches as high as V+). The three network resistors can be represented as R1//R3 in series with R2.

The lower input trip voltage VA1 is defined as

$$V_{A1} = V_{CC}R_2 / ((R_1//R_3) + R_2)$$

When VIN is greater than VA, the output voltage is low or very close to ground. In this case the three network resistors can be presented as R2//R3 in series with R1.

The upper trip voltage VA2 is defined as

$$V_{A2} = V_{CC} (R_2//R_3) / ((R_1 + (R_2//R_3))$$

The total hysteresis provided by the network is defined as ΔVA = VA1 - VA2

$$\Delta V_A = \frac{+V_{CC}R_1R_2}{R_1R_2 + R_1R_3 + R_2R_3}$$

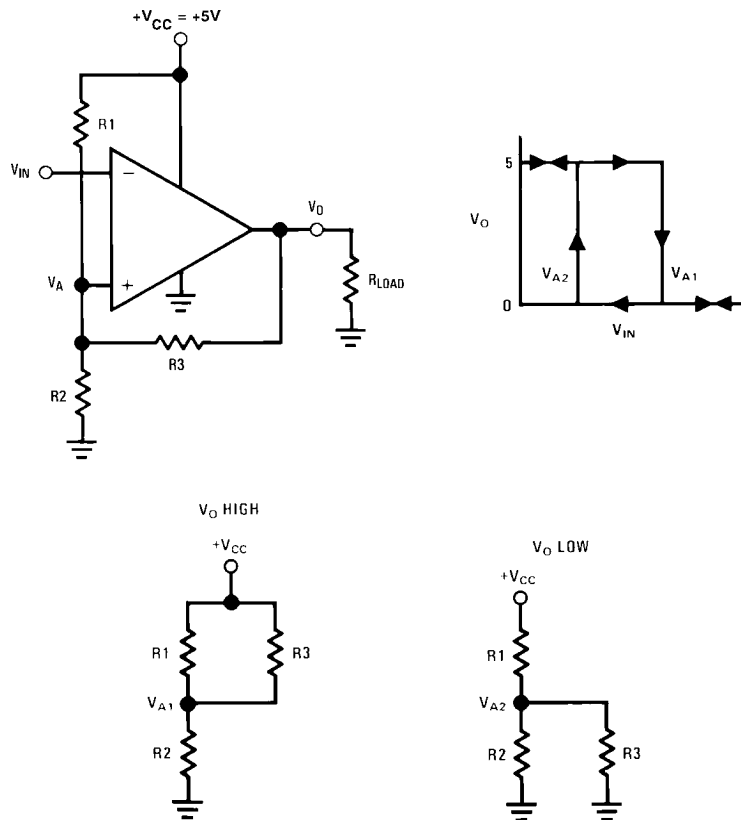

20123634

FIGURE 3. Inverting Comparator with Hysteresis

NON-INVERTING COMPARATOR WITH HYSTERESIS

A non-inverting comparator with hysteresis requires a two-resistor network, and a voltage reference (V_{REF}) at the inverting input. When V_{IN} is low, the output is also low. For the output to switch from low to high, V_{IN} must rise up to V_{IN1} where V_{IN1} is calculated by:

$$V_{in1} = \frac{V_{ref}(R_1 + R_2)}{R_2}$$

As soon as V_O switches to V_{CC} , V_A will step to a value greater than V_{REF} , which is given by

$$V_A = V_{IN} + \frac{(V_{CC}-V_{IN1})R_1}{R_1 + R_2}$$

To make the comparator switch back to its low state, V_{IN} must equal V_{REF} before V_A will again equal V_{REF} . V_{IN2} can be calculated by

$$V_{in2} = \frac{V_{ref}(R_1 + R_2) - V_{CC}R_1}{R_2}$$

The hysteresis of this circuit is the difference between V_{IN1} and V_{IN2} .

$$\Delta V_{IN} = V_{CC}R_1/R_2$$

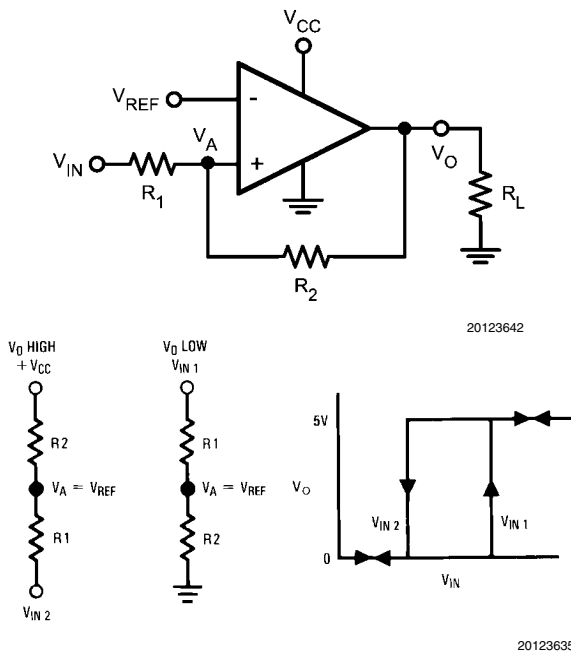

FIGURE 4. Non-Inverting Comparator with Hysteresis

ZERO CROSSING DETECTOR

In a zero crossing detector circuit, the inverting input is connected to ground and the non-inverting input is connected to a 100 mV_{pp} AC signal. As the signal at the non-inverting input crosses 0V, the comparator's output changes state.

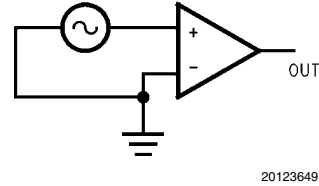

FIGURE 5. Zero Crossing Detector

To improve switching times and centering the input threshold to ground a small amount of positive feedback is added to the circuit. Voltage divider R_4 and R_5 establishes a reference voltage, V_1 , at the positive input. By making the series resistance, R_1 plus R_2 equal to R_5 , the switching condition, $V_1 = V_2$, will be satisfied when $V_{IN} = 0$. The positive feedback resistor, R_6 , is made very large with respect to R_5 ($R_6 = 2000 R_5$). The resultant hysteresis established by this network is very small ($\Delta V_1 < 10$ mV) but it is sufficient to insure rapid output voltage transitions. Diode D_1 is used to insure that the inverting input terminal of the comparator never goes below approximately -100 mV. As the input terminal goes negative, D_1 will forward bias, clamping the node between R_1 and R_2 to approximately -700 mV. This sets up a voltage divider with R_2 and R_3 preventing V_2 from going below ground. The maximum negative input overdrive is limited by the current handling ability of D_1 .

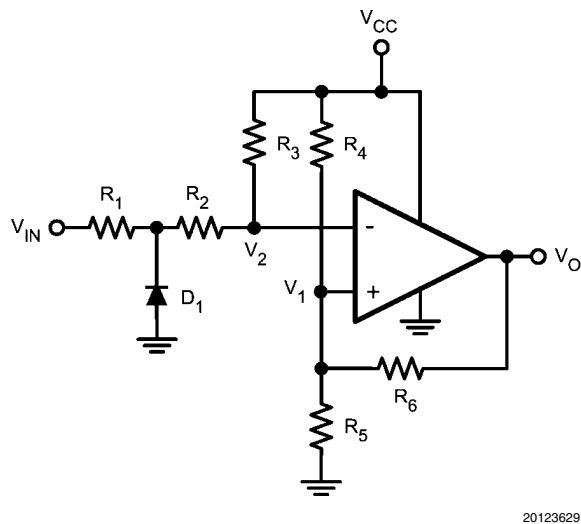
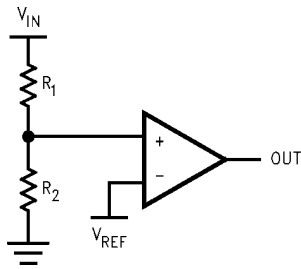

FIGURE 6. Zero Crossing Detector with Positive Feedback

THRESHOLD DETECTOR

Instead of tying the inverting input to 0V, the inverting input can be tied to a reference voltage. As the input on the non-inverting input passes the V_{REF} threshold, the comparator's output changes state. It is important to use a stable reference voltage to ensure a consistent switching point.



20123630

FIGURE 7. Threshold Detector

CRYSTAL OSCILLATOR

A simple crystal oscillator using the LPV7215 is shown in *Figure 8*. Resistors R_1 and R_2 set the bias point at the comparator's non-inverting input. Resistors, R_3 and R_4 and capacitor C_1 set the inverting input node at an appropriate DC average level based on the output. The crystal's path provides resonant positive feedback and stable oscillation occurs. The output duty cycle for this circuit is roughly 50%, but it is affected by resistor tolerances and to a lesser extent by the comparator offset.

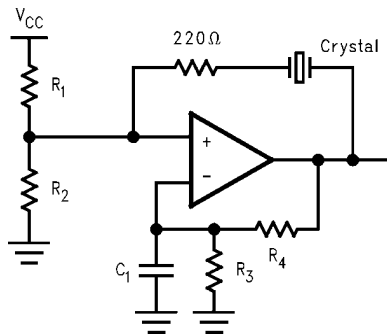

20123631

FIGURE 8. Crystal Oscillator

IR RECEIVER

The LPV7215 can also be used as an infrared receiver. The infrared photo diode creates a current relative to the amount of infrared light present. The current creates a voltage across R_D . When this voltage level crosses the voltage applied by the voltage divider to the inverting input, the output transitions.

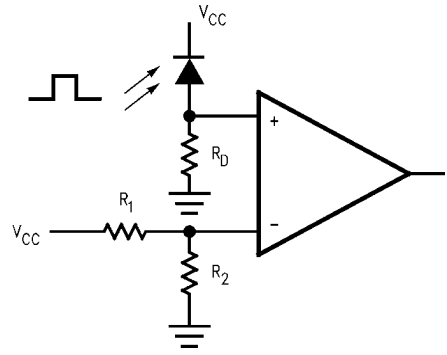

20123632

FIGURE 9. IR Receiver

SQUARE WAVE GENERATOR

A typical application for a comparator is as a square wave oscillator. The circuit in *Figure 10* generates a square wave whose period is set by the RC time constant of the capacitor C_1 and resistor R_4 . The maximum frequency is limited by the large signal propagation delay of the comparator and by the capacitive loading at the output, which limits the output slew rate.

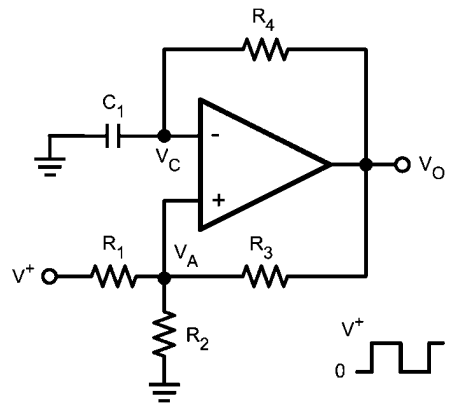

20123638

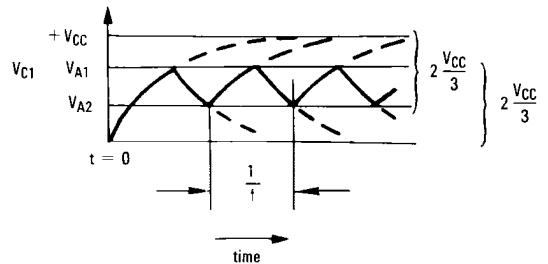

20123639

FIGURE 10. Square Wave Oscillator

Consider the output of *Figure 10* to be high to analyze the circuit. That implies that the inverted input (V_C) is lower than the non-inverting input (V_A). This causes the C_1 to be charged through R_4 , and the voltage V_C increases until it is equal to the non-inverting input. The value of V_A at this point is

$$V_{A1} = \frac{V_{CC} \cdot R_2}{R_2 + R_1 \parallel R_3}$$

If $R_1 = R_2 = R_3$ then $V_{A1} = 2V_{CC}/3$

At this point the comparator switches pulling down the output to the negative rail. The value of V_A at this point is

$$V_{A2} = \frac{V_{CC} (R_2 \parallel R_3)}{R_1 + (R_2 \parallel R_3)}$$

If $R_1 = R_2 = R_3$ then $V_{A2} = V_{CC}/3$

The capacitor C_1 now discharges through R_4 , and the voltage V_C decreases until it is equal to V_{A2} , at which point the comparator switches again, bringing it back to the initial stage. The time period is equal to twice the time it takes to discharge C_1 from $2V_{CC}/3$ to $V_{CC}/3$, which is given by $R_4 C_1 \cdot \ln 2$. Hence the formula for the frequency is:

$$F = 1/(2 \cdot R_4 \cdot C_1 \cdot \ln 2)$$

WINDOW DETECTOR

A window detector monitors the input signal to determine if it falls between two voltage levels.

The comparator outputs A and B are high only when

$V_{REF1} < V_{IN} < V_{REF2}$ "or within the window."

where these are defined as

$$V_{REF1} = R_3 / (R_1 + R_2 + R_3) * V^+$$

$$V_{REF2} = (R_2 + R_3) / (R_1 + R_2 + R_3) * V^+$$

Others names for window detectors are: threshold detector, level detectors, and amplitude trigger or detector.

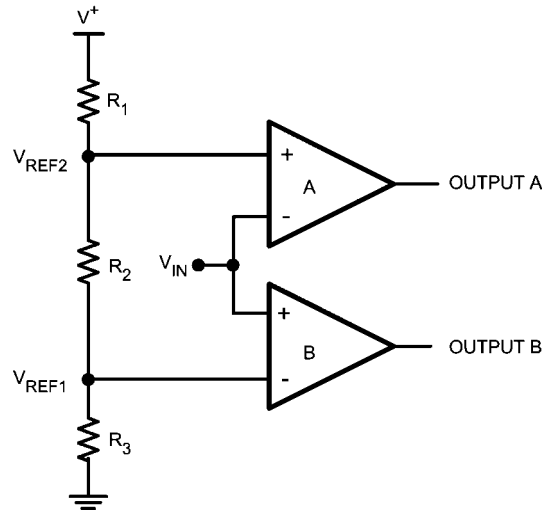

20123647

FIGURE 11. Window Detector

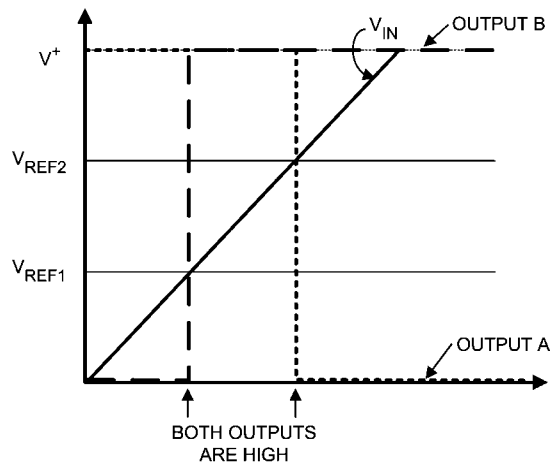

20123648

FIGURE 12. Window Detector Output Signal

Physical Dimensions inches (millimeters) unless otherwise noted

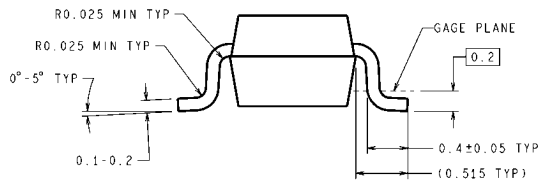
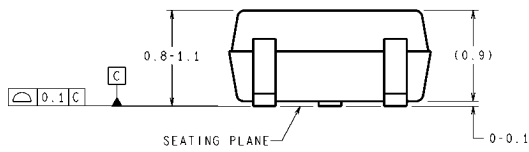
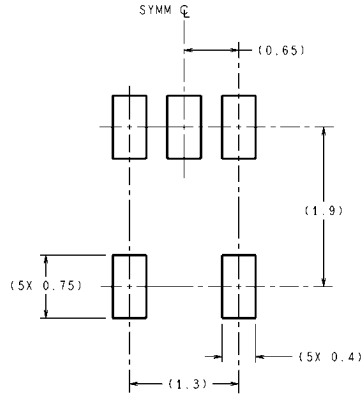
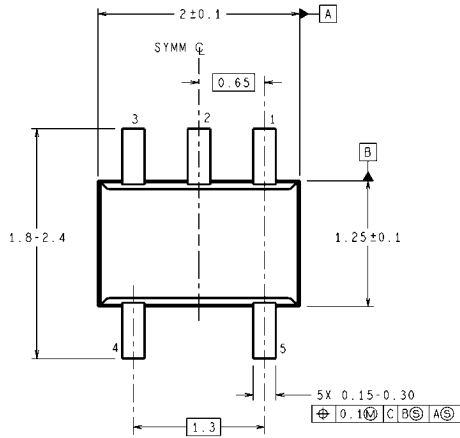

DIMENSIONS ARE IN MILLIMETERS
5-Pin SC70
 NS Package Number MAA05A

MAA05A (Rev C)

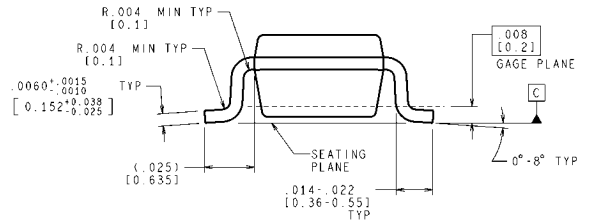
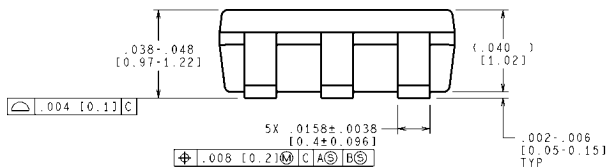
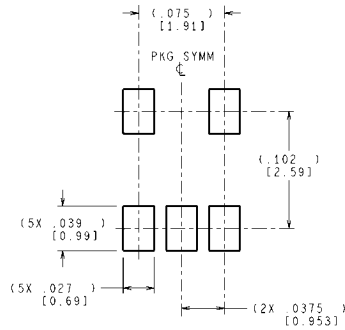
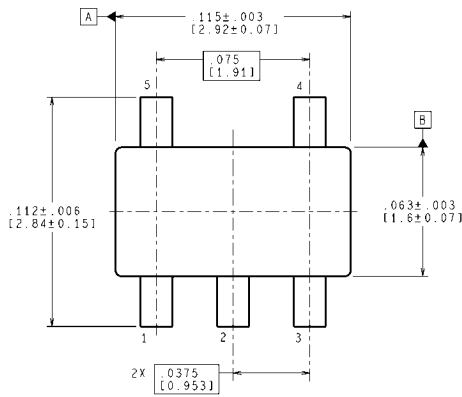

CONTROLLING DIMENSION IS INCH
 VALUES IN [] ARE MILLIMETERS
 DIMENSIONS IN () FOR REFERENCE ONLY

5-Pin SOT23
 NS Package Number MF05A

MF05A (Rev C)

Notes

LPV7215

Notes

THE CONTENTS OF THIS DOCUMENT ARE PROVIDED IN CONNECTION WITH NATIONAL SEMICONDUCTOR CORPORATION ("NATIONAL") PRODUCTS. NATIONAL MAKES NO REPRESENTATIONS OR WARRANTIES WITH RESPECT TO THE ACCURACY OR COMPLETENESS OF THE CONTENTS OF THIS PUBLICATION AND RESERVES THE RIGHT TO MAKE CHANGES TO SPECIFICATIONS AND PRODUCT DESCRIPTIONS AT ANY TIME WITHOUT NOTICE. NO LICENSE, WHETHER EXPRESS, IMPLIED, ARISING BY ESTOPPEL OR OTHERWISE, TO ANY INTELLECTUAL PROPERTY RIGHTS IS GRANTED BY THIS DOCUMENT.

TESTING AND OTHER QUALITY CONTROLS ARE USED TO THE EXTENT NATIONAL DEEMS NECESSARY TO SUPPORT NATIONAL'S PRODUCT WARRANTY. EXCEPT WHERE MANDATED BY GOVERNMENT REQUIREMENTS, TESTING OF ALL PARAMETERS OF EACH PRODUCT IS NOT NECESSARILY PERFORMED. NATIONAL ASSUMES NO LIABILITY FOR APPLICATIONS ASSISTANCE OR BUYER PRODUCT DESIGN. BUYERS ARE RESPONSIBLE FOR THEIR PRODUCTS AND APPLICATIONS USING NATIONAL COMPONENTS. PRIOR TO USING OR DISTRIBUTING ANY PRODUCTS THAT INCLUDE NATIONAL COMPONENTS, BUYERS SHOULD PROVIDE ADEQUATE DESIGN, TESTING AND OPERATING SAFEGUARDS.

EXCEPT AS PROVIDED IN NATIONAL'S TERMS AND CONDITIONS OF SALE FOR SUCH PRODUCTS, NATIONAL ASSUMES NO LIABILITY WHATSOEVER, AND NATIONAL DISCLAIMS ANY EXPRESS OR IMPLIED WARRANTY RELATING TO THE SALE AND/OR USE OF NATIONAL PRODUCTS INCLUDING LIABILITY OR WARRANTIES RELATING TO FITNESS FOR A PARTICULAR PURPOSE, MERCHANTABILITY, OR INFRINGEMENT OF ANY PATENT, COPYRIGHT OR OTHER INTELLECTUAL PROPERTY RIGHT.

LIFE SUPPORT POLICY

NATIONAL'S PRODUCTS ARE NOT AUTHORIZED FOR USE AS CRITICAL COMPONENTS IN LIFE SUPPORT DEVICES OR SYSTEMS WITHOUT THE EXPRESS PRIOR WRITTEN APPROVAL OF THE CHIEF EXECUTIVE OFFICER AND GENERAL COUNSEL OF NATIONAL SEMICONDUCTOR CORPORATION. As used herein:

Life support devices or systems are devices which (a) are intended for surgical implant into the body, or (b) support or sustain life and whose failure to perform when properly used in accordance with instructions for use provided in the labeling can be reasonably expected to result in a significant injury to the user. A critical component is any component in a life support device or system whose failure to perform can be reasonably expected to cause the failure of the life support device or system or to affect its safety or effectiveness.

National Semiconductor and the National Semiconductor logo are registered trademarks of National Semiconductor Corporation. All other brand or product names may be trademarks or registered trademarks of their respective holders.

Copyright© 2006 National Semiconductor Corporation

For the most current product information visit us at www.national.com



National Semiconductor Americas Customer Support Center
 Email: new.feedback@nsc.com
 Tel: 1-800-272-9959

National Semiconductor Europe Customer Support Center
 Fax: +49 (0) 180-530-85-86
 Email: europe.support@nsc.com
 Deutsch Tel: +49 (0) 69 9508 6208
 English Tel: +49 (0) 870 24 0 2171
 Français Tel: +33 (0) 1 41 91 8790

National Semiconductor Asia Pacific Customer Support Center
 Email: ap.support@nsc.com

National Semiconductor Japan Customer Support Center
 Fax: 81-3-5639-7507
 Email: jpn.feedback@nsc.com
 Tel: 81-3-5639-7560