

LMP8275

High Common Mode, Gain of 20, Precision Voltage Difference Amplifier

General Description

The LMP8275 is a fixed gain differential amplifier with a $-2V$ to $27V$ input common mode voltage range and a supply voltage range of $4.75V$ to $5.5V$. The LMP8275 is part of the LMP™ precision amplifier family which will detect, amplify and filter small differential signals in the presence of high common mode voltages. The gain is fixed at 20 and is adequate to drive an ADC to full scale in most cases. This gain is achieved in two stages, a preamplifier with a fixed gain of 10 and a second stage amplifier with a fixed gain of 2. The internal signal path between these two stages is brought out on two pins, A1 and A2, which provide a connection for a filter network.

The LMP8275 will operate with reduced specifications over the extended common mode input voltage range of $-2V$ to $36V$. This feature makes the device suitable for applications with load dump in automotive systems.

Features

Typical Values, $T_A = 25^\circ C$

■ Input offset voltage	± 2 mV max
■ TCVo _s	± 30 $\mu V/^\circ C$ max
■ CMRR	80 dB min
■ Extended CMVR	$-2V$ to $36V$
■ Output voltage swing	Rail-to-rail
■ Bandwidth	80 kHz
■ Operating temperature range (ambient)	$-40^\circ C$ to $125^\circ C$
■ Supply voltage	$4.75V$ to $5.5V$
■ Supply current	1 mA

Applications

- Fuel injection control
- High and low side driver configuration current sensing
- Power management systems

Typical Application

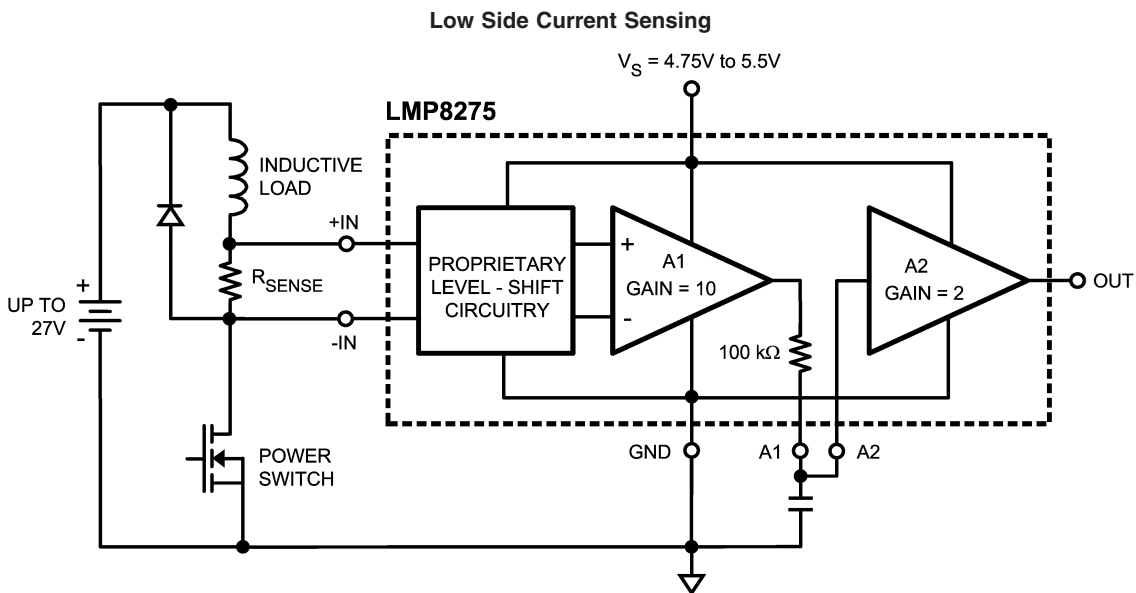

Absolute Maximum Ratings (Note 1)

If Military/Aerospace specified devices are required, please contact the National Semiconductor Sales Office/Distributors for availability and specifications.

ESD Tolerance (Note 2)	
Human Body Model	
For +IN and -IN	±4000V
For all other pins	±2000V
Machine Model	200V
Supply Voltage (V_S - GND)	5.75V
Voltage on +IN and -IN	-5V to 42V
Transient (400 ms)	-7V to 45V
Storage Temperature Range	-65°C to +150°C

Junction Temperature (Note 3)	+150°C
Soldering Information	
Infrared or Convection (20 sec)	235°C
Wave Soldering Lead Temp. (10 sec)	260°C

Operating Ratings (Note 1)

Temperature Range	
Packaged Device (Note 3)	-40°C to +125°C
Supply Voltage (V_S - GND)	4.75V to 5.5V
Package Thermal Resistance (θ_{JA} (Note 3))	
8-Pin SOIC	190°C/W

5V Electrical Characteristics (Note 4)

Unless otherwise specified, all are limits guaranteed for $T_A = 25^\circ\text{C}$, $V_S = 5\text{V}$, GND = 0V, $-2\text{V} \leq V_{CM} \leq 27\text{V}$, $R_L = \text{Open}$. **Bold-face** limits apply at the temperature extremes.

Symbol	Parameter	Conditions		Min	Typ (Note 5)	Max	Units
V_{OS}	Input Offset Voltage	$V_{CM} = V_S/2$			±0.25	±2.0	mV
TCV_{OS}	Input Offset Voltage Drift	$V_{CM} = V_S/2$			±20	±30	$\mu\text{V}/^\circ\text{C}$
		$-40^\circ\text{C} \leq T_A \leq 25^\circ\text{C}$			±20	±35	
A2 I_B	Input Bias Current of A2	(Note 6)			-20		fA
						±20	nA
I_S	Supply Current				1.0	1.2 1.4	mA
R_{CM}	Input Impedance Common Mode			160	200	240	k Ω
R_{DM}	Input Impedance Differential Mode			320	400	480	k Ω
CMVR	Input Common-Mode Voltage Range			-2		+27	V
ECMVR	Extended Common-Mode Voltage Range			-2		36	V
DC CMRR	DC Common Mode Rejection Ratio	$0^\circ\text{C} \leq T_A \leq 125^\circ\text{C}$	$-2\text{V} \leq V_{CM} \leq 27\text{V}$	80	103		dB
			$-2\text{V} \leq V_{CM} \leq 36\text{V}$	60			
		$-40^\circ\text{C} \leq T_A \leq 0^\circ\text{C}$	$-2\text{V} \leq V_{CM} \leq 27\text{V}$	77			
			$-2\text{V} \leq V_{CM} \leq 36\text{V}$	60			
AC CMRR	AC Common Mode Rejection Ratio (Note 7)	$-2\text{V} \leq V_{CM} \leq 27\text{V}$	$f = 1\text{ kHz}$	80	95		dB
		$-2\text{V} \leq V_{CM} \leq 27\text{V}$	$f = 10\text{ kHz}$		78		
PSRR	Power Supply Rejection Ratio	$4.75\text{V} \leq V_S \leq 5.5\text{V}$		70	80		dB
R_{F-INT}	Filter Resistor			97	100	103	k Ω
TCR_{F-INT}	Filter Resistor Drift				±20		ppm/ $^\circ\text{C}$
A_V	Total Gain			19.8	20	20.2	V/V
	Gain Drift				±2	±25	ppm/ $^\circ\text{C}$
A_{V1}	A1 Gain			9.9	10	10.1	V/V
A_{V2}	A2 Gain			1.98	2.0	2.02	V/V
A1 V_{OUT}	A1 Output Voltage Swing	VOL			0.004	0.01	V
		VOH		4.80	4.95		
A2 V_{OUT}	A2 Output Voltage Swing (Notes 8, 9)	$R_L = 100\text{ k}\Omega$ on Output	VOL		0.007	0.02	V
			VOH	4.80	4.99		
		$R_L = 10\text{ k}\Omega$ on Output	VOL		0.03		V
			VOH		4.95		
SR	Slew Rate (Note 10)				0.7		V/ μs

5V Electrical Characteristics (Note 4) (Continued)

Unless otherwise specified, all are limits guaranteed for $T_A = 25^\circ\text{C}$, $V_S = 5\text{V}$, $\text{GND} = 0\text{V}$, $-2\text{V} \leq V_{\text{CM}} \leq 27\text{V}$, $R_L = \text{Open}$. **Bold-face** limits apply at the temperature extremes.

Symbol	Parameter	Conditions	Min	Typ (Note 5)	Max	Units
BW	Bandwidth			80		kHz
Noise	0.1 Hz to 10 Hz			5.7		μV_{PP}
	Spectral Density	$f = 1 \text{ kHz}$		452		$\text{nV}/\sqrt{\text{Hz}}$

Note 1: Absolute Maximum Ratings indicate limits beyond which damage to the device may occur. Operating Ratings indicate conditions for which the device is intended to be functional, but specific performance is not guaranteed. For guaranteed specifications and the test conditions, see the Electrical Characteristics Tables.

Note 2: Human Body Model is $1.5 \text{ k}\Omega$ in series with 100 pF . Machine Model is 0Ω in series with 200 pF .

Note 3: The maximum power dissipation is a function of $T_{\text{J}(\text{MAX})}$, θ_{JA} , and T_A . The maximum allowable power dissipation at any ambient temperature is $P_D = (T_{\text{J}(\text{MAX})} - T_A) / \theta_{\text{JA}}$. All numbers apply for packages soldered directly onto a PC board.

Note 4: Electrical table values apply only for factory testing conditions at the temperature indicated. Factory testing conditions result in very limited self-heating of the device.

Note 5: Typical values represent the parametric norm at the time of characterization.

Note 6: Positive current corresponds to current flowing into the device.

Note 7: AC Common Mode Signal is a 24 V_{PP} sine-wave (0V to 24V) at the given frequency

Note 8: For VOL, R_L is connected to V_S and for VOH, R_L is connected to GND.

Note 9: For this test input is driven from A1 stage.

Note 10: Slew rate is the average of the rising and falling slew rates.

Connection Diagram

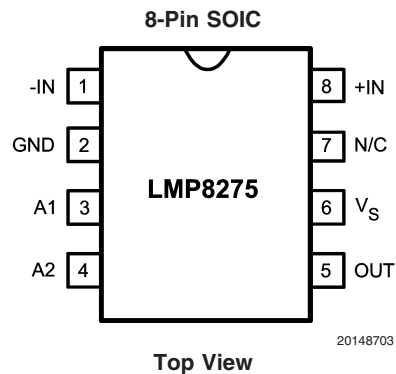

Ordering Information

Package	Part Number	Package Marking	Transport Media	NSC Drawing
8-Pin SOIC	LMP8275MA	LMP8275MA	95 Units/Rail	M08A
	LMP8275MAX		2.5k Units Tape and Reel	

Typical Performance Characteristics Unless otherwise specified: $T_A = 25^\circ\text{C}$, $V_S = 5\text{V}$, $V_{CM} = V_S/2$

V_{OS} vs. V_{CM} Over Temperature

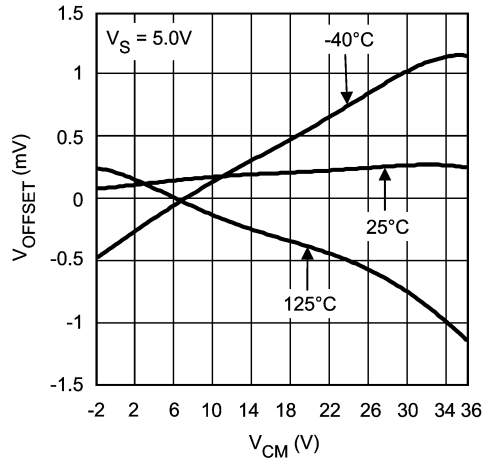

20148715

Typical V_{OS} vs. Temperature

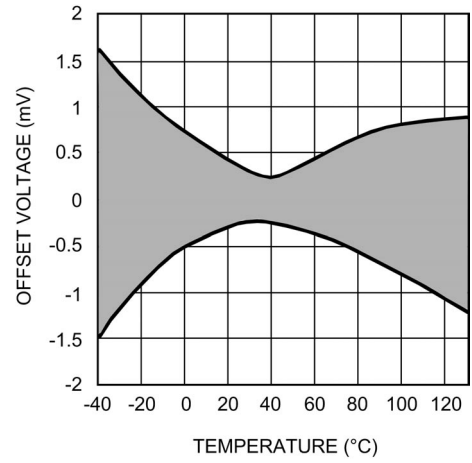

20148721

Input Bias Current Over Temperature (A1 Inputs)

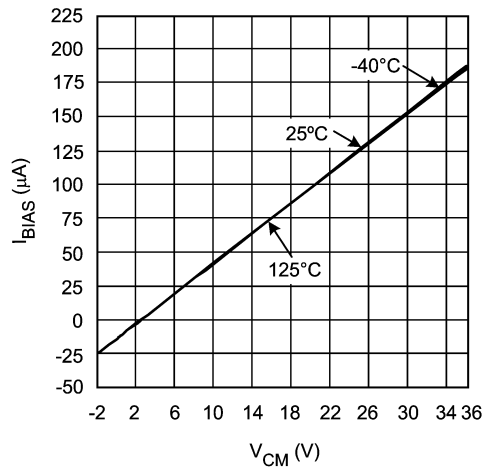

20148719

Input Bias Current Over Temperature (A2 Input)

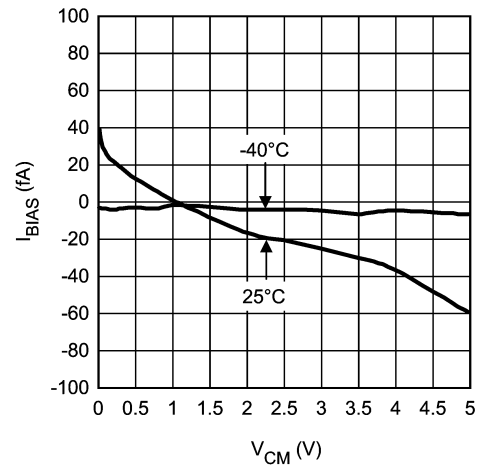

20148718

Input Bias Current Over Temperature (A2 Input)

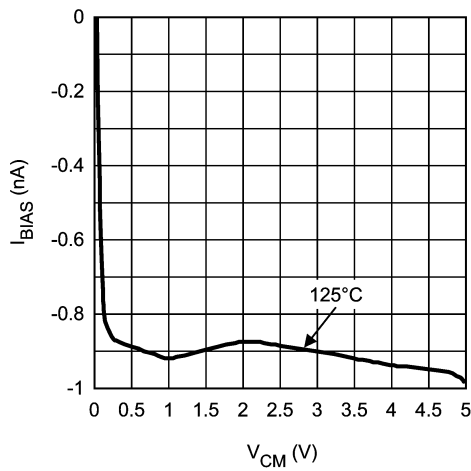

20148720

Input Referred Voltage Noise vs. Frequency

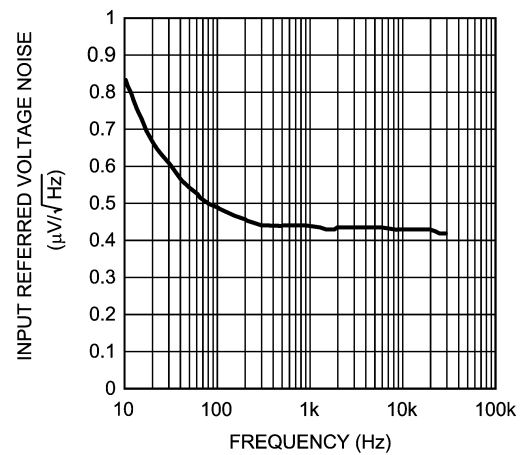

20148706

Typical Performance Characteristics Unless otherwise specified: $T_A = 25^\circ\text{C}$, $V_S = 5\text{V}$, $V_{\text{CM}} = V_S/2$
 (Continued)

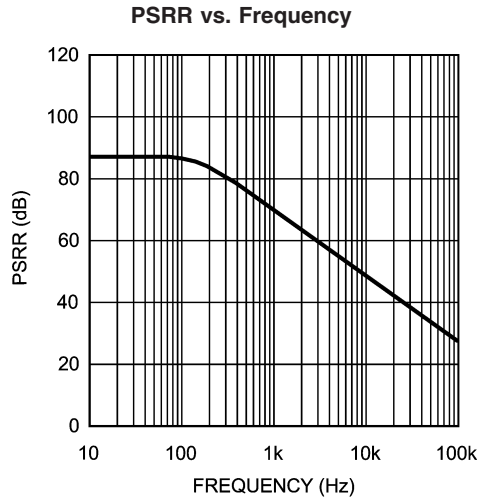

20148723

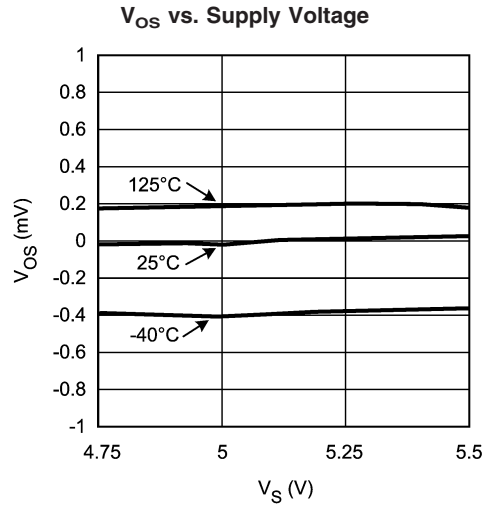

20148722

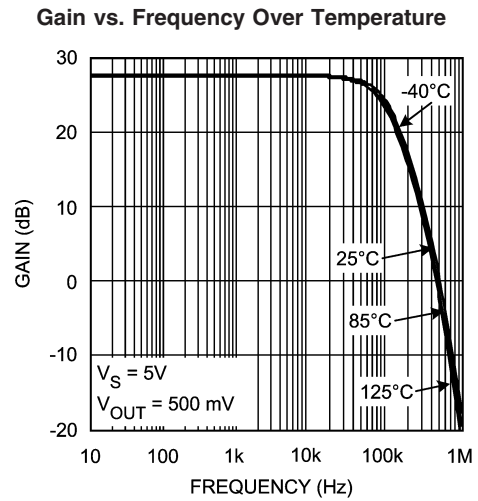

20148712

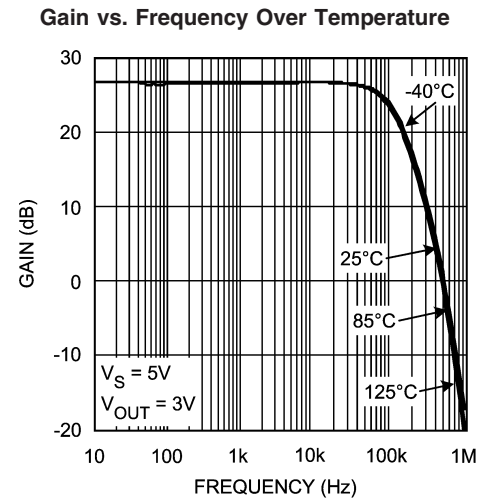

20148711

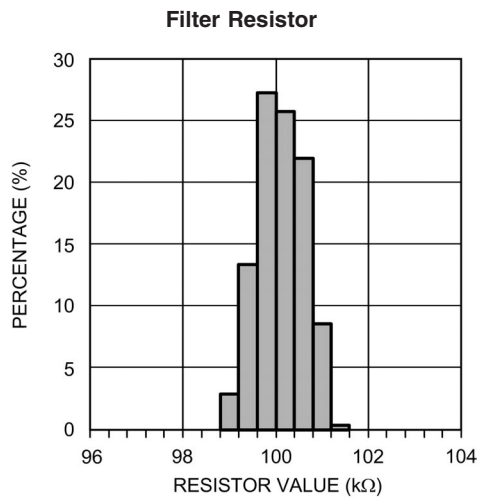

20148717

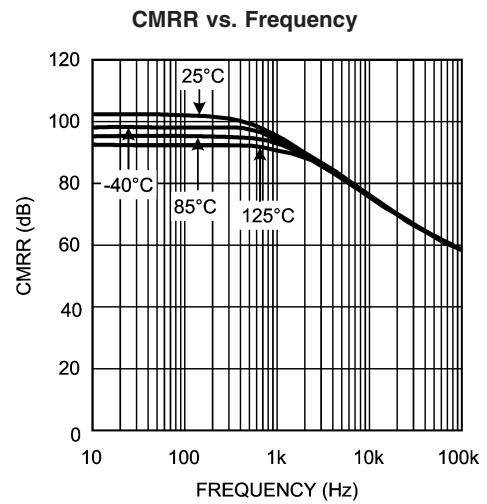

20148714

Typical Performance Characteristics

(Continued)

Unless otherwise specified: $T_A = 25^\circ\text{C}$, $V_S = 5\text{V}$, $V_{CM} = V_S/2$

Settling Time (Rising Edge)

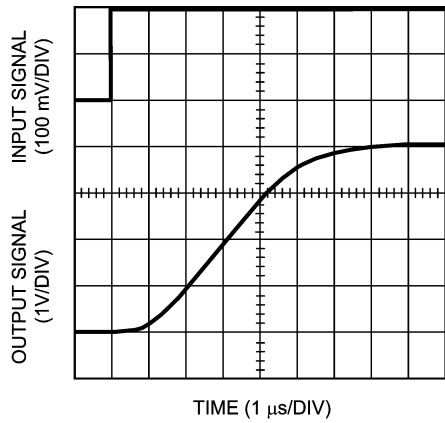

20148710

Settling Time (Falling Edge)

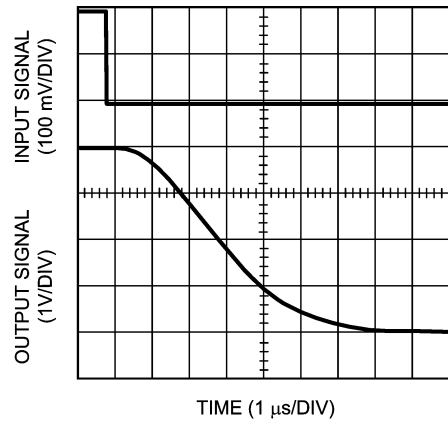

20148709

Output Voltage vs. R_L to V_S

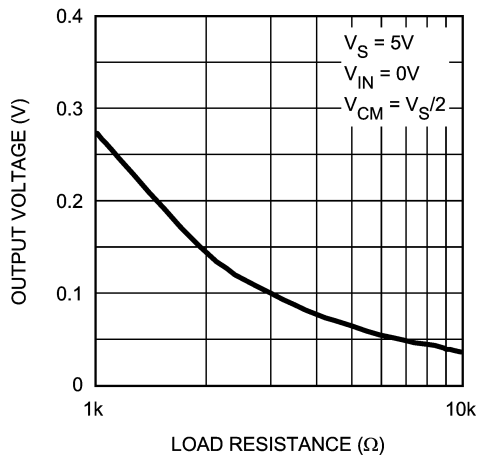

20148713

Output Voltage vs. R_L to GND

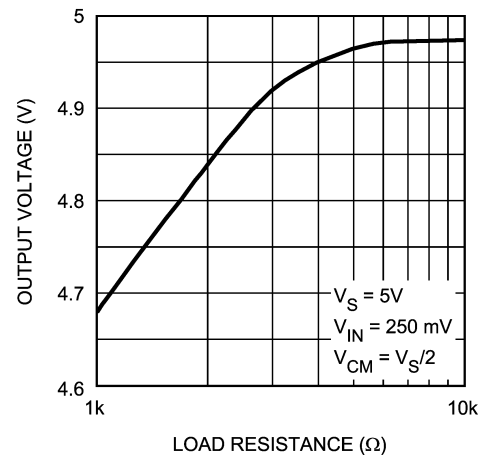

20148707

Step Response

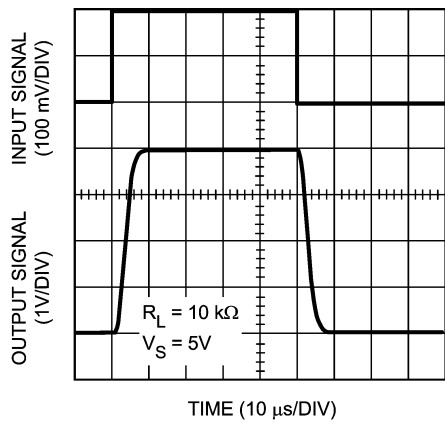

20148708

Application Note

LMP8275

The LMP8275 is a single supply amplifiers with a fixed gain of 20 and an extended common mode voltage range of -2V to 36V. The fixed gain is achieved in two separate stages, a preamplifier with gain of +10 and a second stage amplifier with gain of +2. A block diagram of the LMP8275 is shown in Figure 1.

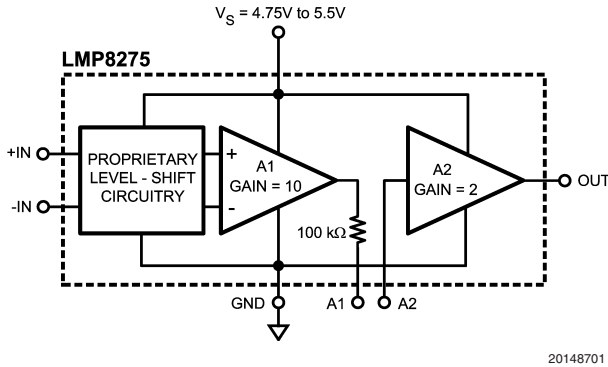

FIGURE 1. LMP8275

The overall offset of the LMP8275 is minimized by trimming amplifier A1. This is done in such a way that the output referred offset of A1 cancels the input referred offset of A2 or $10V_{OS1} = -V_{OS2}$.

Because of this offset voltage relationship, the offset of each individual amplifier stage may be more than the limit specified for the overall system in the datasheet tables. If the signal going from A1 to A2 is amplified or attenuated (by use of amplifiers and resistors), the overall LMP8275 offset will be affected as a result. Filtering the signal between A1 and A2 or simply connecting the two pins will not change the offset of the LMP8275.

Referencing input referred offset voltages, the following relationship holds:

$$\frac{(10V_{OS1}) + (V_{OS2})}{10} = V_{OS}(\text{LMP8275})$$

If the signal on pin 3 is scaled, attenuated or amplified, by a factor X, then the offset of the overall system will become:

$$\frac{(10V_{OS1}) \times (X) + (V_{OS2})}{10(X)} = V_{OS}(\text{LMP8275})$$

POWER SUPPLY DECOUPLING

In order to decouple the LMP8275 from AC noise on the power supply, it is recommended to use a 0.1 μF on the supply pin. It is best to use a 0.1 μF capacitor in parallel with a 10 μF capacitor. This will generate an AC path to ground for most frequency ranges and will greatly reduce the noise introduced by the power supply.

SECOND ORDER LOW PASS FILTER

The LMP8275 can be effectively used to build a second order Sallen-Key low pass filter. The general filter is shown in

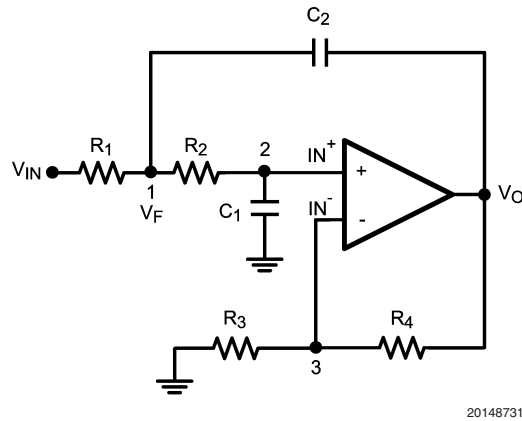

FIGURE 2. Second Order Low-Pass Filter

With the general transfer function:

$$\frac{V_O}{V_{IN}} = \frac{K}{M - KN} \tag{1}$$

Where

$$M = s^2C_1C_2R_1R_2 + s(R_1C_1 + R_1C_2 + C_1R_2) + 1$$

$$N = sC_2R_1$$

and

$$\frac{1}{K} = \frac{1}{A_{VOL}} + \frac{R_3}{R_3 + R_4}$$

K represents the sum of DC closed loop gain and the non-ideal behavior of the operational amplifier. Assuming ideal behavior, the equation for K reduces simply to the DC gain, which is +2 for the LMP8275.

The LMP8275 can be used to realize this configuration as shown in Figure 3:

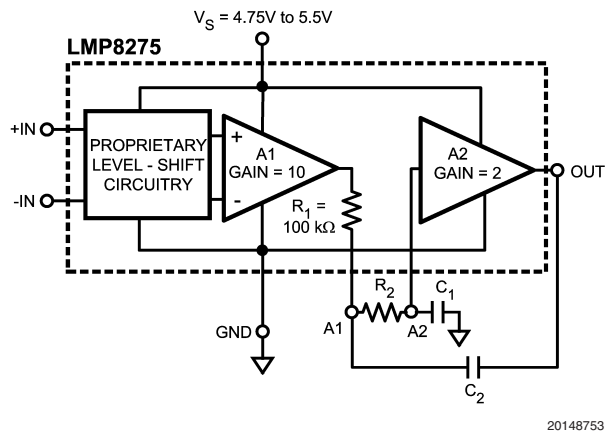

FIGURE 3. Low-Pass Filter With LMP8275

Application Note (Continued)

Assuming ideal behavior, the equation for K reduces simply to the DC gain, which is set for +2 for the LMP8270.

Using *Equation (1)*, the filter parameters can be calculated as follows:

$$\omega_o = \frac{1}{\sqrt{R_1 R_2 C_1 C_2}}$$

$$f_c = \frac{1}{2\pi \sqrt{R_1 R_2 C_1 C_2}}$$

$$Q = \frac{\sqrt{R_1 R_2 C_1 C_2}}{R_1 C_1 + R_2 C_1 + (1-K)R_1 C_2}$$

for the LMP8275, $R_1 = 100 \text{ k}\Omega$. Setting $R_1 = R_2$ and $C_1 = C_2$ results in a low pass filter with $Q = 1$. Since the values of resistors are predetermined, the corner frequency of this implementation of the filter depends on the capacitor values.

GAINS OTHER THAN 20

The LMP8275 has an internal gain of +20; however this gain can be modified. The signal path between the two amplifiers is available as external pins.

GAINS LESS THAN 20

Figure 4 shows the configuration used to reduce the LMP8275 gain.

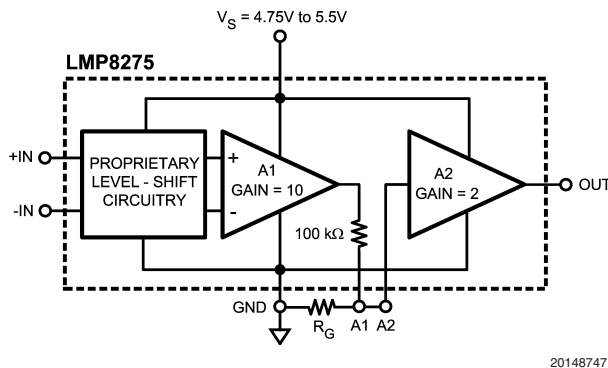

FIGURE 4. Gains Less Than 20

Where:

$$\text{GAIN (NEW)} = \frac{20 R_G}{R_G + 100 \text{ k}\Omega}$$

and

$$R_G = (100 \text{ k}\Omega) \frac{\text{GAIN (NEW)}}{20 - \text{GAIN (NEW)}}$$

GAINS GREATER THAN 20

A higher gain can be achieved by using positive feedback on the second stage amplifier, A2, of LMP8275. *Figure 5* shows the configuration:

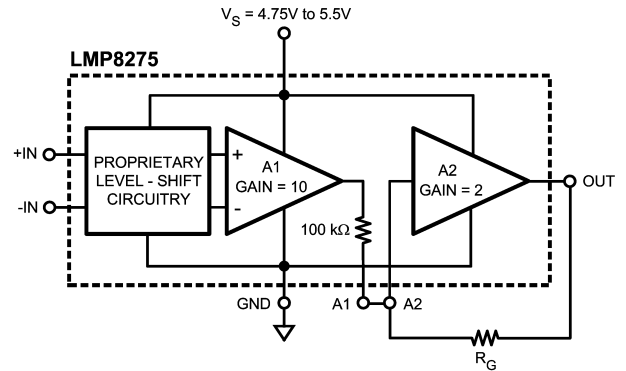

FIGURE 5. Gains Greater Than 20

The total gain is given by:

$$\text{GAIN (NEW)} = \frac{20 R_G}{R_G - 100 \text{ k}\Omega} \quad (2)$$

Which can be rearranged to calculate R_G :

$$R_G = (100 \text{ k}\Omega) \frac{\text{GAIN (NEW)}}{\text{GAIN (NEW)} - 20}$$

The inverting gain of the second amplifier is set at 2, giving the total system a gain of 20. The non-inverting gain which is achieved through positive gain can be less than or equal to this gain without any issues. This implies a total gain of 40 or less is easily achievable. Once the positive gain surpasses the negative gain, the system might oscillate.

As the value of gain resistor, R_G , approaches that of the internal $100 \text{ k}\Omega$ resistor, maintaining gain accuracy will become more challenging. This is because Gain(new) is inversely proportional to $(R_G - 100 \text{ k}\Omega)$, see *Equation (2)*. As $R_G \rightarrow 100 \text{ k}\Omega$, the denominator of *Equation (2)* gets smaller. This smaller value will be comparable to the tolerance of the $100 \text{ k}\Omega$ resistor and R_G and hence the gain will be dominated by accuracy level of these resistors and the gain tolerance will be determined by the tolerance of the external resistor used for R_G and the 3% tolerance of the internal $100 \text{ k}\Omega$ resistor.

CURRENT LOOP RECEIVER

Many types of process control instrumentation use 4 to 20 mA transmitters to transmit the sensor's analog value to a central control room. The LMP8275 can be used as a current loop receiver as shown in *Figure 6*.

Application Note (Continued)

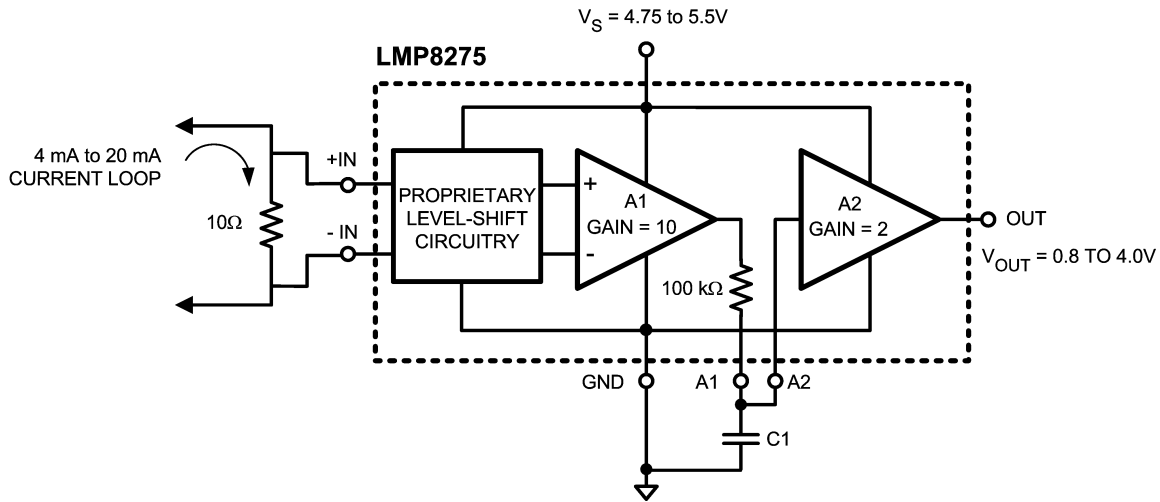

20148724

FIGURE 6. Current Loop Receiver

HIGH SIDE CURRENT SENSING

High side current measurement requires a differential amplifier with gain. Here the DC voltage source represent a common mode voltage with the +IN input at the supply voltage and the -IN input very close to the supply voltage. The LMP8275 can be used with a common mode voltage, V_{DC} in this case, of up to 36V.

The LMP8275 can be used for high side current sensing. The large common mode voltage range of this device allows

it to sense signals outside of its supply voltage range. Also, the LMP8275 has very high CMRR, which enables it to sense very small signals in the presence of larger common mode signals. The system in *Figure 7* couples these two characteristics of the LMP8275 in an automotive application. The signal through R_{S1} is detected and amplified by the LMP8275 in the presence of a common mode signal of up to 27V with the highest accuracy.

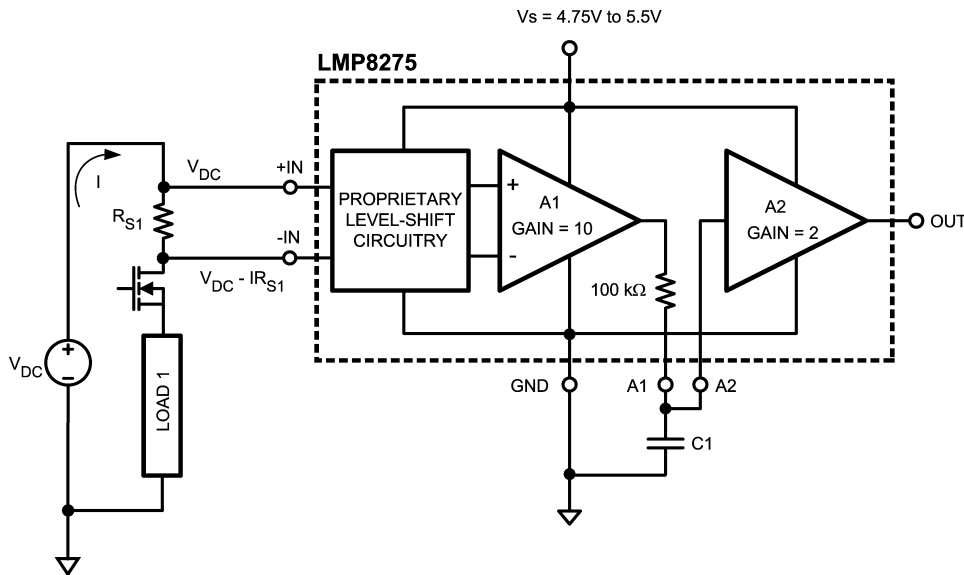

20148725

FIGURE 7. High Side Current Sensing

Application Note (Continued)

LOW SIDE CURRENT SENSING

Low side current measurements can cause a problem for operational amplifiers by exceeding the negative common mode voltage limit of the device. In *Figure 8*, the load current is returning to the power source through a common connection that has a parasitic resistance. The voltage drop across

the parasitic resistances can cause the ground connection of the measurement circuits to be at a positive voltage with respect to the common side of the sense resistor. This will result in one or both of the inputs being negative with respect to the measurement circuit's ground. The LMP8275 has a wide input common mode voltage range of $-2V$ to $36V$ and will function in this condition.

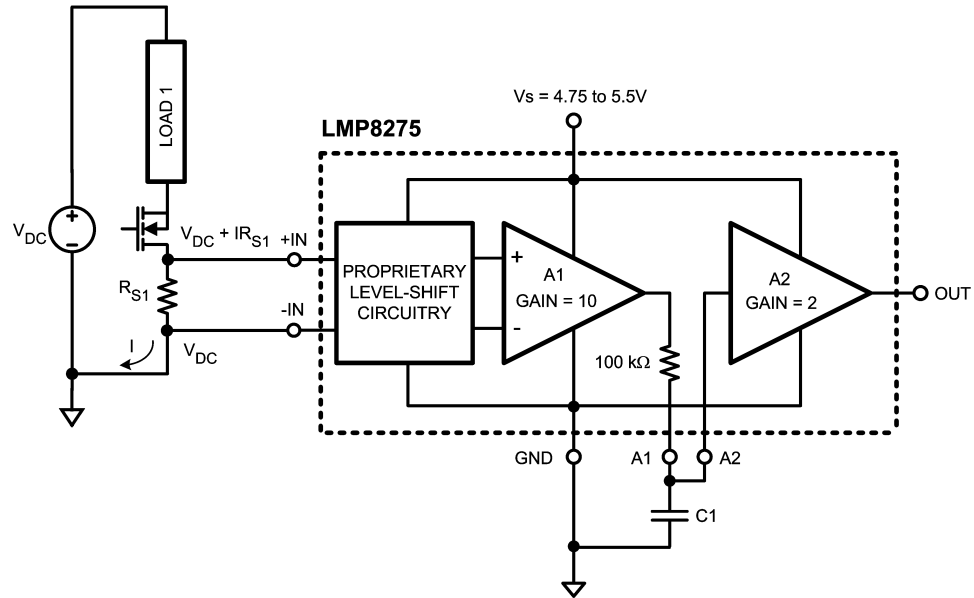

20148726

FIGURE 8. Low Side Current Sensing

Physical Dimensions inches (millimeters) unless otherwise noted

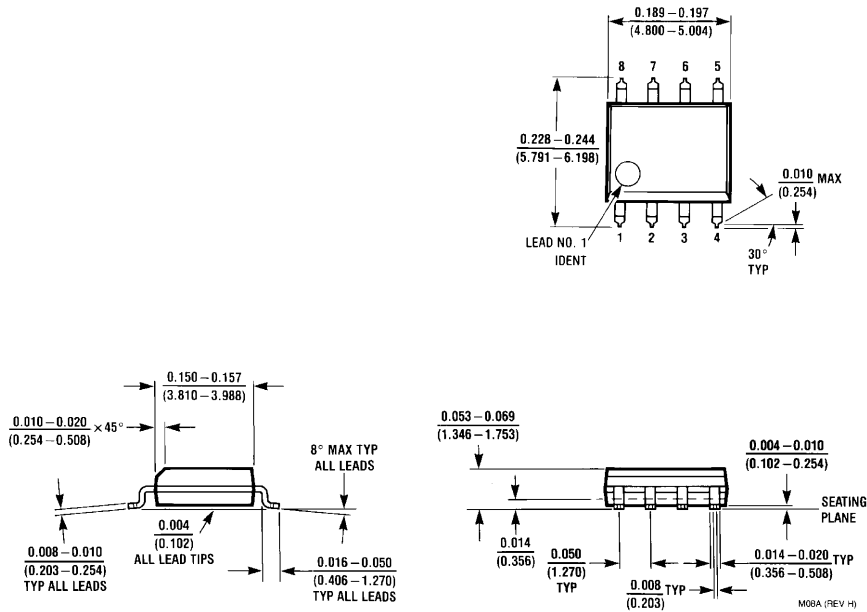

**8-Pin SOIC
NS Package Number M08A**

National does not assume any responsibility for use of any circuitry described, no circuit patent licenses are implied and National reserves the right at any time without notice to change said circuitry and specifications.
For the most current product information visit us at www.national.com.

LIFE SUPPORT POLICY

NATIONAL'S PRODUCTS ARE NOT AUTHORIZED FOR USE AS CRITICAL COMPONENTS IN LIFE SUPPORT DEVICES OR SYSTEMS WITHOUT THE EXPRESS WRITTEN APPROVAL OF THE PRESIDENT AND GENERAL COUNSEL OF NATIONAL SEMICONDUCTOR CORPORATION. As used herein:

1. Life support devices or systems are devices or systems which, (a) are intended for surgical implant into the body, or (b) support or sustain life, and whose failure to perform when properly used in accordance with instructions for use provided in the labeling, can be reasonably expected to result in a significant injury to the user.
2. A critical component is any component of a life support device or system whose failure to perform can be reasonably expected to cause the failure of the life support device or system, or to affect its safety or effectiveness.

BANNED SUBSTANCE COMPLIANCE

National Semiconductor follows the provisions of the Product Stewardship Guide for Customers (CSP-9-111C2) and Banned Substances and Materials of Interest Specification (CSP-9-111S2) for regulatory environmental compliance. Details may be found at: www.national.com/quality/green.

Lead free products are RoHS compliant.



National Semiconductor
Americas Customer
Support Center
Email: new.feedback@nsc.com
Tel: 1-800-272-9959

National Semiconductor
Europe Customer Support Center
Fax: +49 (0) 180-530 85 86
Email: europe.support@nsc.com
Deutsch Tel: +49 (0) 69 9508 6208
English Tel: +44 (0) 870 24 0 2171
Français Tel: +33 (0) 1 41 91 8790

National Semiconductor
Asia Pacific Customer
Support Center
Email: ap.support@nsc.com

National Semiconductor
Japan Customer Support Center
Fax: 81-3-5639-7507
Email: jpn.feedback@nsc.com
Tel: 81-3-5639-7560