

FSUSB23

Low Power Hi-Speed USB 2.0 (480Mbps) Switch

Features

- 10 μ A maximum I_{CC}T current over an expanded control voltage range (V_{IN} = 2.6V, V_{CC} = 3.6V)
- Lower Capacitance: Con = 9pF Typ
- 7 Ω typical On Resistance (R_{ON})
- -3dB bandwidth: > 720MHz
- Low power consumption (1 μ A maximum)
- Packaged in:
 - Pb-Free 10-lead MicroPak™ (1.6mm x 2.1mm)
 - Pb-Free 16-lead DQFN
 - Pb-Free 10-lead MSOP
- 7kV I/O to GND ESD performance

Applications

- Cell phone, PDA, Digital Camera, and Notebook
- LCD Monitor, TV, and Set-top Box

General Description

The FSUSB23 is a low power high bandwidth analog switch specifically designed for high speed USB 2.0 applications. The FSUSB23 features very low quiescent current even when the control voltage is lower than the V_{CC} supply. This feature services mobile handset applications well allowing for direct interface with the base-band processor general purpose I/Os. Typical applications involve switching in portables and consumer applications such as cell phones, digital cameras, and notebooks with hubs or controllers. The wide bandwidth (>720MHz) of this switch exceeds the bandwidth needed to pass the 3rd harmonic which results in signals with minimum edge and phase distortion. Superior channel-to-channel crosstalk results in minimal interference.

Ordering Information

Order Number	Package Number	Product Code Top Mark	Package Description
FSUSB23L10X	MAC010A	EZ	Pb-Free 10-Lead MicroPak, 1.6mm x 2.1mm
FSUSB23BQX	MLP016E	USB23	Pb-Free 16-Terminal Depopulated Quad Very-Thin Flat Pack No Leads (DQFN), JEDEC MO-241, 2.5 x 3.5mm
FSUSB23MUX (Preliminary)	MUA10A	USB23	Pb-Free 10-Lead Molded Small Outline Package (MSOP), JEDEC MO-187, 3.0mm Wide

Pb-Free package per JEDEC J-STD-020B.

MicroPak™ is a trademark of Fairchild Semiconductor Corporation.

Connection Diagrams

Pad Assignments for MicroPak

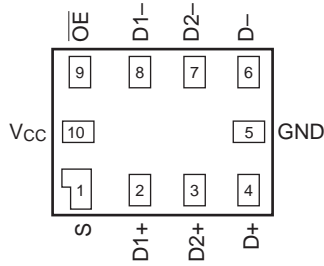

(Top View)

Pad Assignments for DQFN

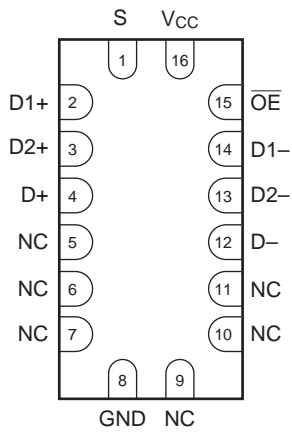

(Top Through View)

Pin Assignment for MSOP

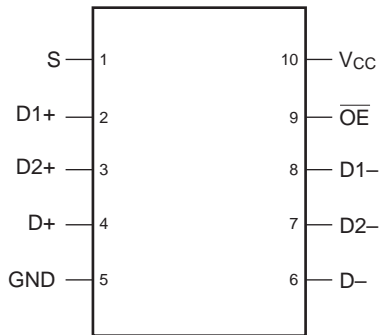

(Top Through View)

Analog Symbol

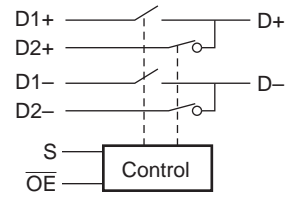

Pin Descriptions

Pin Name	Description
OE	Bus Switch Enable
S	Select Input
D+, D-, Dn+, Dn-	Data Ports

Truth Table/s

S	OE	Function
X	H	Disconnect
L	L	D+, D- = D1 _n
H	L	D+, D- = D2 _n

Absolute Maximum Ratings

The "Absolute Maximum Ratings" are those values beyond which the safety of the device cannot be guaranteed. The device should not be operated at these limits. The parametric values defined in the Electrical Characteristics tables are not guaranteed at the absolute maximum ratings. The "Recommended Operating Conditions" table will define the conditions for actual device operation.

Symbol	Parameter	Rating
V_{CC}	Supply Voltage	-0.5V to +4.6V
	DC Switch Voltage ⁽¹⁾	-0.5V to $V_{CC} + 0.5V$
V_{IN}	DC Input Voltage ⁽¹⁾	-0.5V to +4.6V
	DC Input Diode Current	-50mA
	DC Output Current	50mA
	Storage Temperature	-65°C to +150°C
	ESD (Human Body Model)	
	All Pins	7kV
	I/O to GND	7kV

Recommended Operating Conditions⁽²⁾

Symbol	Parameter	Rating
V_{CC}	Supply Voltage	3.0V to 3.6V
	Control Input Voltage	0V to V_{CC}
	Switch Input Voltage	0V to V_{CC}
	Operating Temperature	-40°C to +85°C
	Thermal Resistance 10 MicroPak	250°C/W

Notes:

- The input and output negative voltage ratings may be exceeded if the input and output diode current ratings are observed. DC switch voltage may never exceed 4.6V.
- Control input must be held HIGH or LOW and it must not float.

DC Electrical Characteristics

(All typical values are @ 25°C unless otherwise specified.)

Symbol	Parameter	Conditions	V _{CC} (V)	T _A = -40°C to +85°C			Units
				Min.	Typ.	Max.	
V _{IK}	Clamp Diode Voltage	I _{IN} = -18mA	3.0			-1.2	V
V _{IH}	Input Voltage HIGH		3.0 to 3.6	1.2			V
V _{IL}	Input Voltage LOW		3.0 to 3.6			0.50	V
I _{IN}	Control Input Leakage	V _{IN} = 0V to V _{CC}	3.6			1.0	μA
I _{OZ}	OFF State Leakage	0 ≤ D _n , D1 _n , D2 _n ≤ V _{CC}				1.0	μA
R _{ON}	Switch On Resistance ⁽³⁾	V _{IN} = 0.4V, I _{ON} = -8mA	3.0		6.0	9.0	Ω
		V _{IN} = 0.8V, I _{ON} = -8mA			7.0	10.0	
ΔR _{ON}	Delta R _{ON} ⁽⁴⁾	V _{IN} = 0.8V, I _{ON} = -8mA	3.0		0.3		Ω
R _{ON} Flatness	R _{ON} Flatness ⁽³⁾	V _{IN} = 0.0V – 1.0V, I _{ON} = -8mA	3.0		2.0		Ω
I _{CC}	Quiescent Supply Current	V _{IN} = 0.0V or V _{CC} , I _{OUT} = 0	3.6			1.0	μA
I _{CC} T	Increase in I _{CC} Current per Control Voltage and V _{CC} Levels	V _{IN} = 2.6V, V _{CC} = 3.6V	3.6			10.0	μA

AC Electrical Characteristics

(All typical values are for V_{CC} = 3.3V @ 25°C unless otherwise specified.)

Symbol	Parameter	Conditions	V _{CC} (V)	T _A = -40°C to +85°C			Units	Figure Number
				Min.	Typ.	Max.		
t _{ON}	Turn On Time S, \overline{OE} to Output	V _{D1n} , D2 _n = 0.8V, R _L = 50Ω, C _L = 10pF	3.0 to 3.6		10.0	13.0	ns	Figure 5
t _{OFF}	Turn OFF Time S, \overline{OE} to Output	V _{D1n} , D2 _n = 0.8V, R _L = 50Ω, C _L = 10pF	3.0 to 3.6		8.0	11.0	ns	Figure 5
t _{PD}	Propagation Delay ⁽⁴⁾	R _L = 50Ω, C _L = 10pF	3.3		0.25		ns	Figure 3 Figure 4
O _{IRR}	OFF Isolation (Non-Adjacent)	f = 250MHz, R _T = 50Ω	3.0 to 3.6		-30.0		dB	Figure 8
Xtalk	Non-Adjacent Channel Crosstalk	R _T = 50Ω, f = 250MHz	3.0 to 3.6		-43.0		dB	Figure 9
BW	-3dB Bandwidth	R _T = 50Ω	3.0 to 3.6		720		MHz	Figure 7

Notes:

- Measured by the voltage drop between D_n, D1_n, D2_n pins at the indicated current through the switch. On Resistance is determined by the lower of the voltage on the two ports.
- Guaranteed by characterization.

USB Related AC Electrical Characteristics

Symbol	Parameter	Conditions	V _{CC} (V)	T _A = -40°C to +85°C			Units	Figure Number
				Min.	Typ.	Max.		
t _{SK(O)}	Channel-to-Channel Skew ⁽⁵⁾	R _L = 50Ω, C _L = 10pF	3.0 to 3.6		40.0		ps	Figure 3 Figure 6
t _{SK(P)}	Skew of Opposite Transitions of the Same Output ⁽⁵⁾	R _L = 50Ω, C _L = 10pF	3.0 to 3.6		20.0		ps	Figure 3 Figure 6
t _J	Total Jitter ⁽⁵⁾	R _L = 50Ω, C _L = 10pF, t _R = t _F = 750ps at 480 Mbps (PRBS = 2 ¹⁵ - 1)	3.0 to 3.6		150		ps	

Note:

5. Guaranteed by design.

Capacitance

Symbol	Parameter	Conditions	T _A = -40°C to +85°C			Units	Figure Number
			Min.	Typ.	Max.		
C _{IN}	Control Pin Input Capacitance	V _{CC} = 0V		2.0		pF	Figure 11
C _{ON}	D1 _n , D2 _n , Dn ON Capacitance	V _{CC} = 3.3, \overline{OE} = 0V		9.0		pF	Figure 10
C _{OFF}	D1 _n , D2 _n OFF Capacitance	V _{CC} and \overline{OE} = 3.3		4.0		pF	Figure 11

Test Diagrams

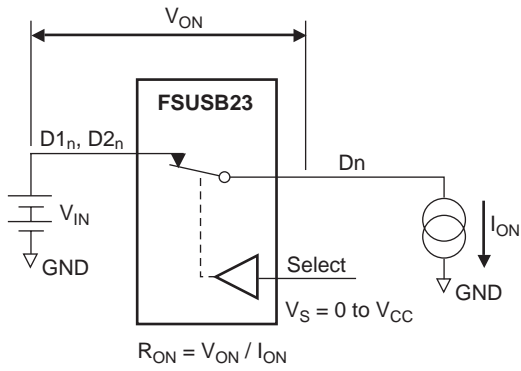
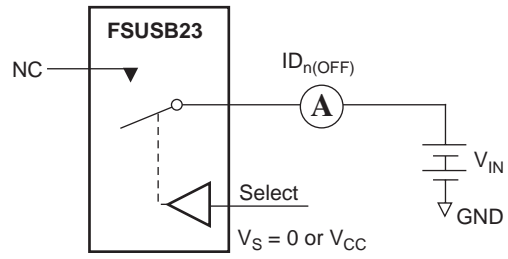
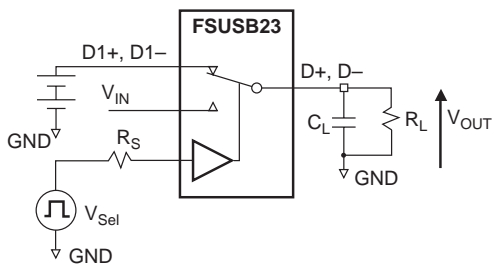

Figure 1. On Resistance



Note: Each switch port is tested separately.

Figure 2. OFF Leakage



Note: R_L , R_S , and C_L are functions of the application environment (see AC Electrical tables for specific values).

Note: C_L includes test fixture and stray capacitance.

Figure 3. AC Test Circuit Load

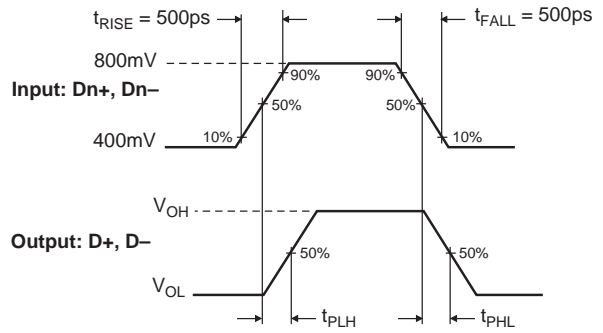

Figure 4. Switch Propagation Delay Waveforms

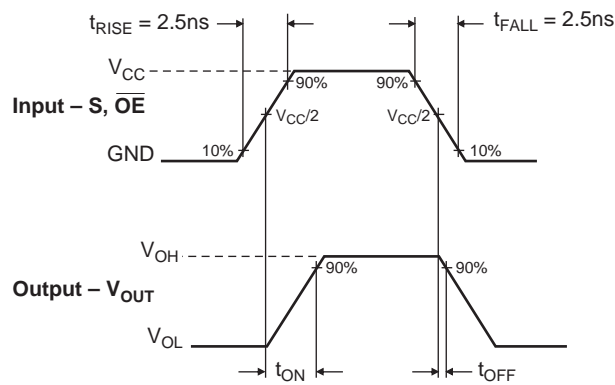

Figure 5. Turn ON/Turn OFF Waveform

Test Diagrams (continued)

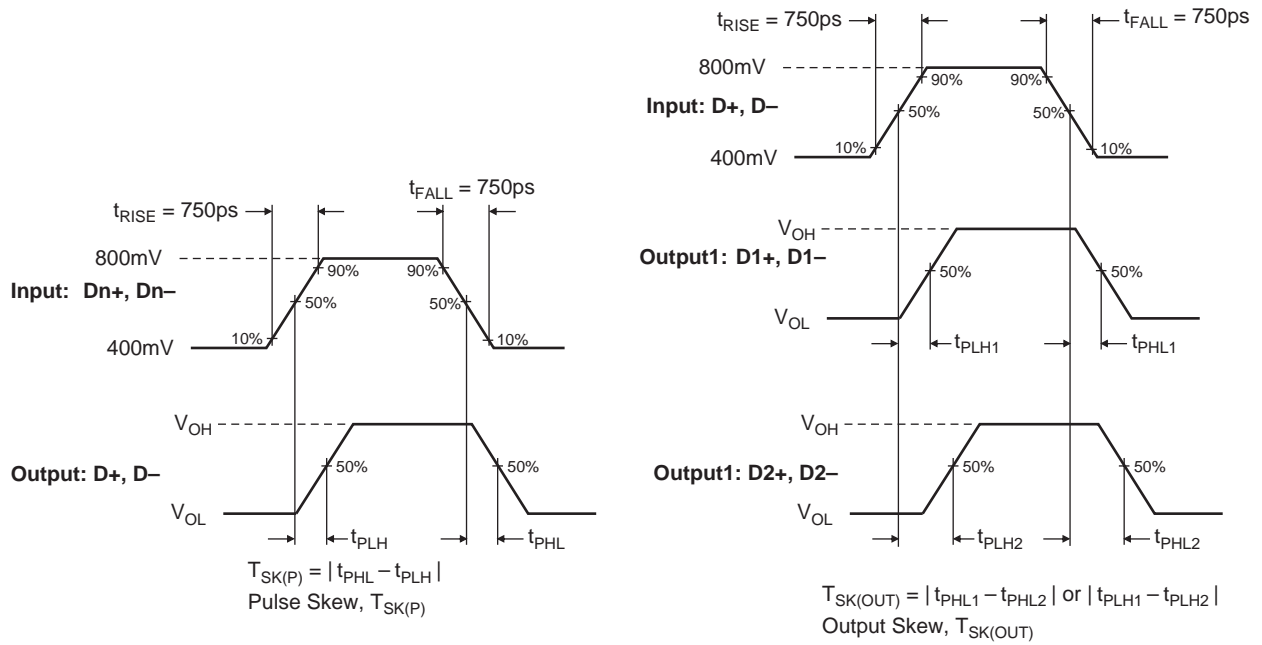

Figure 6. Switch Skew Tests

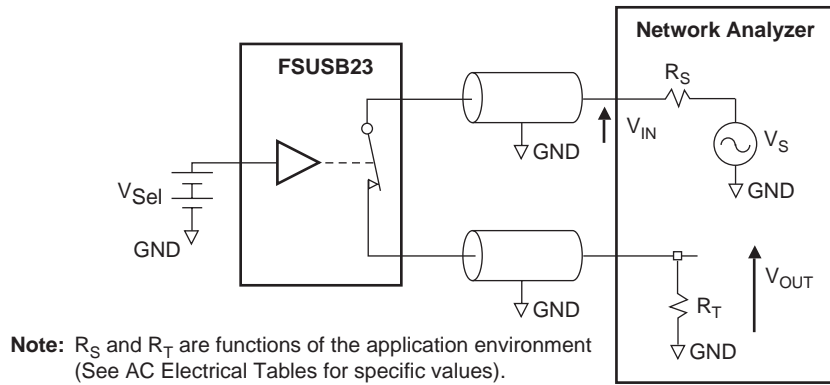

Figure 7. Bandwidth

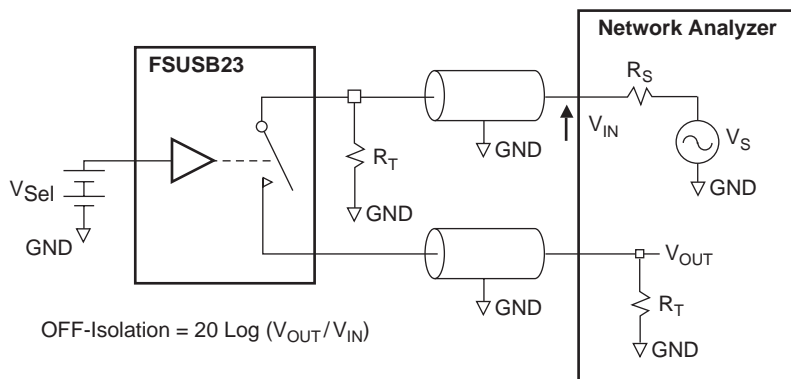

Figure 8. Channel OFF Isolation

Test Diagrams (Continued)

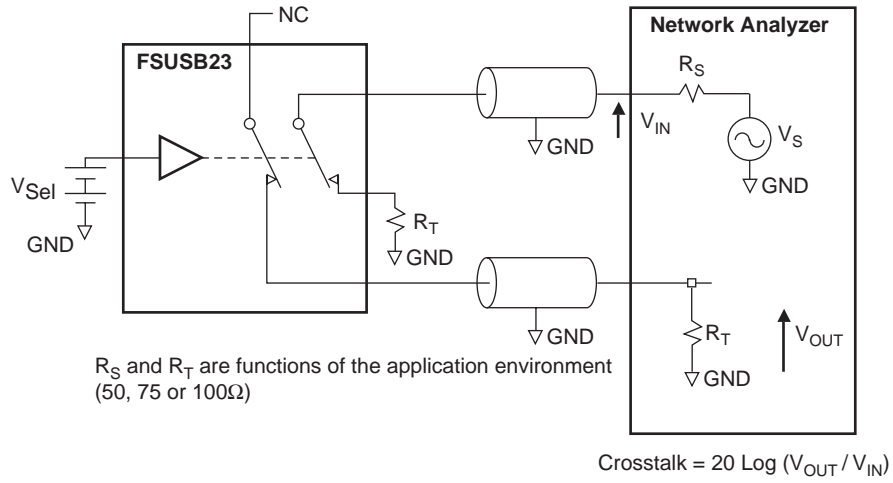

Figure 9. Non-Adjacent Channel-to-Channel Crosstalk

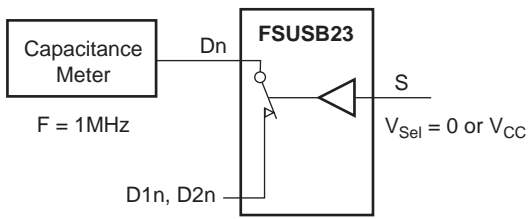

Figure 10. Channel ON Capacitance

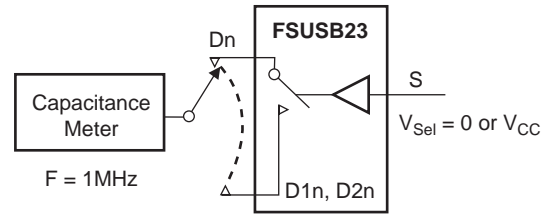

Figure 11. Channel OFF Capacitance

Tape and Reel Specifications

Tape Format for MicroPak

Package Designator	Tape Section	Number Cavities	Cavity Status	Cover Tape Status
L10X	Leader (Start End)	125 (typ)	Empty	Sealed
	Carrier	5000	Filled	Sealed
	Trailer (Hub End)	75 (typ)	Empty	Sealed

Tape Dimension millimeters

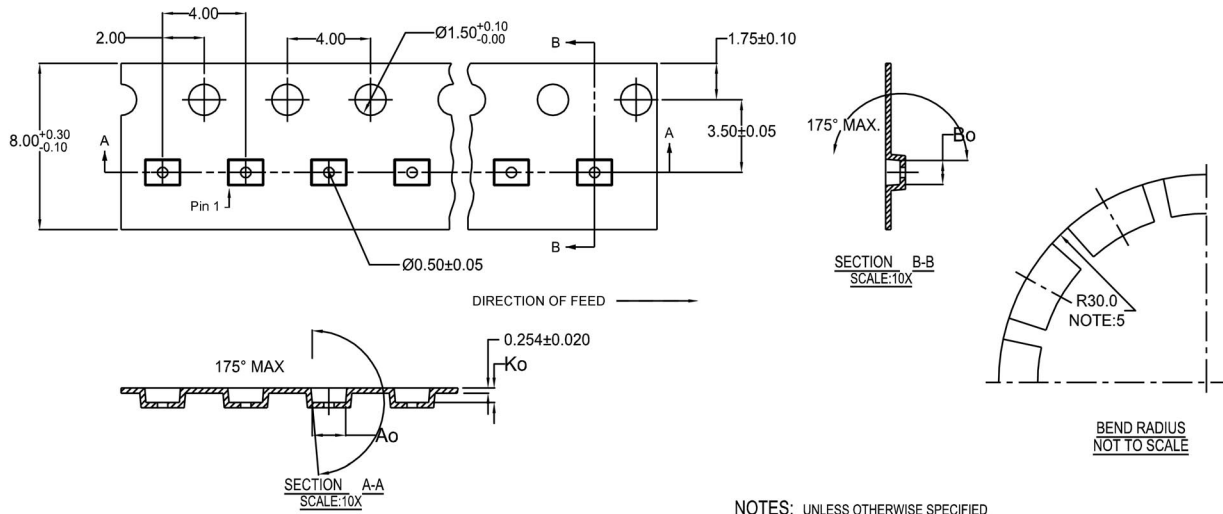

10	300056	2.30±0.05	1.78±0.05	0.68±0.05
8	300038	1.78±0.05	1.78±0.05	0.68±0.05
6	300033	1.60±0.05	1.15±0.05	0.70±0.05

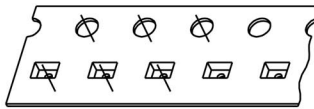

SCALE: 6X

NOTES: UNLESS OTHERWISE SPECIFIED

1. ACCUMULATED 50 SPROCKETS, SPROCKET HOLE PITCH IS 200.00 ±0.30MM
2. NO INDICATED CORNER RADIUS IS 0.127MM
3. CAMBER NOT TO EXCEED 1MM IN 100MM
4. SMALLEST ALLOWABLE BENDING RADIUS
5. POCKET POSITION RELATIVE TO SPROCKET HOLE MEASURED AS TRUE POSITION OF POCKET, NOT POCKET HOLE

Reel Dimension for MicroPak inches (millimeters)

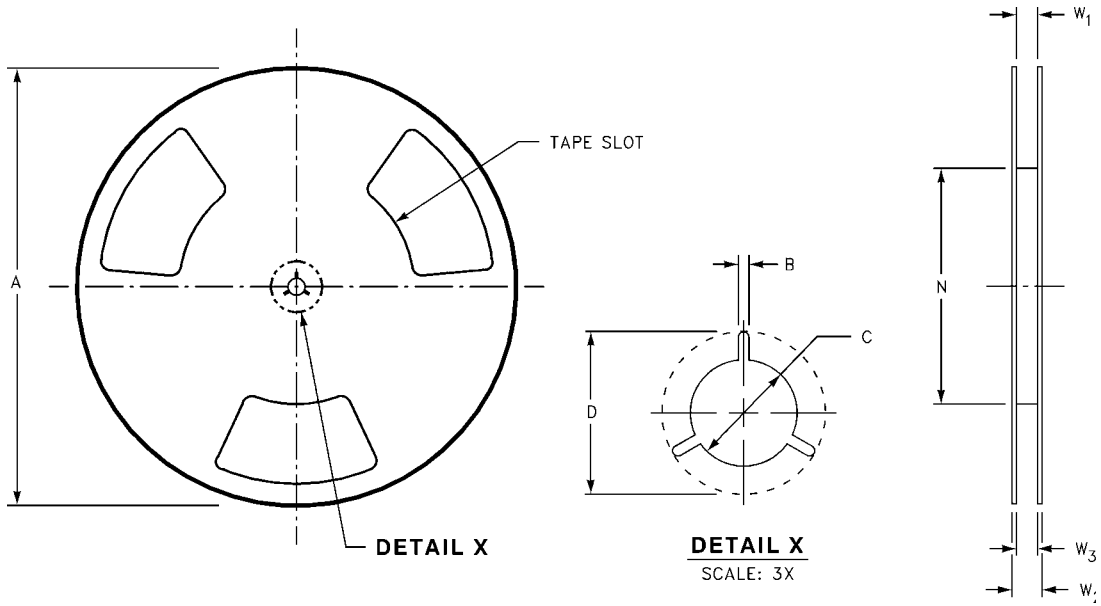

Tape Size	A	B	C	D	N	W1	W2	W3
8mm	7.0 (177.8)	0.059 (1.50)	0.512 (13.00)	0.795 (20.20)	2.165 (55.00)	0.331 +0.059/-0.000 (8.40 +1.50/-0.00)	0.567 (14.40)	W1 +0.078/-0.039 (W1 +2.00/-1.00)

Tape Format for DQFN

Package Designator	Tape Section	Number Cavities	Cavity Status	Cover Tape Status
BQX	Leader (Start End)	125 (typ)	Empty	Sealed
	Carrier	2500/3000	Filled	Sealed
	Trailer (Hub End)	75 (typ)	Empty	Sealed

Tap Dimensions millimeters

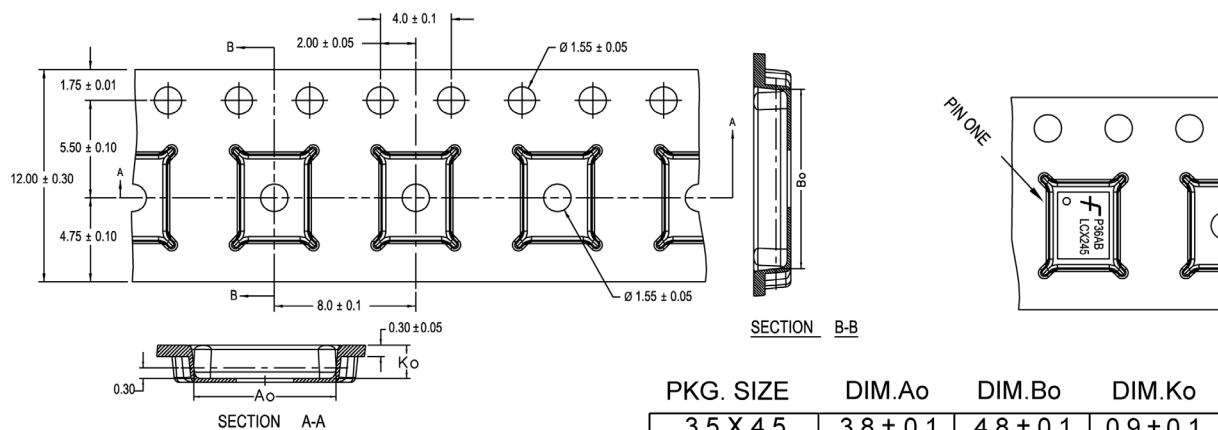

PKG. SIZE	DIM.Ao	DIM.Bo	DIM.Ko
3.5 X 4.5	3.8 ± 0.1	4.8 ± 0.1	0.9 ± 0.1
3.0 X 3.0	3.3 ± 0.1	3.3 ± 0.1	0.9 ± 0.1
2.5 X 4.5	2.8 ± 0.1	4.8 ± 0.1	0.9 ± 0.1
2.5 X 3.5	2.8 ± 0.1	3.8 ± 0.1	0.9 ± 0.1
2.5 X 3.0	2.8 ± 0.1	3.3 ± 0.1	0.9 ± 0.1
2.5 X 2.5	2.8 ± 0.1	2.8 ± 0.1	0.9 ± 0.1

DIMENSIONS ARE IN MILLIMETERS

NOTES: unless otherwise specified

1. Cumulative pitch for feeding holes and cavities (chip pockets) not to exceed 0.008[0.20] over 10 pitch span.
2. Smallest allowable bending radius.
3. Thru hole inside cavity is centered within cavity.
4. Tolerance is $\pm 0.002[0.05]$ for these dimensions on all 12mm tapes.
5. Ao and Bo measured on a plane 0.120[0.30] above the bottom of the pocket.
6. Ko measured from a plane on the inside bottom of the pocket to the top surface of the carrier.
7. Pocket position relative to sprocket hole measured as true position of pocket. Not pocket hole.
8. Controlling dimension is millimeter. Dimension in inches rounded.

Reel Dimensions for DQFN inches (millimeters)

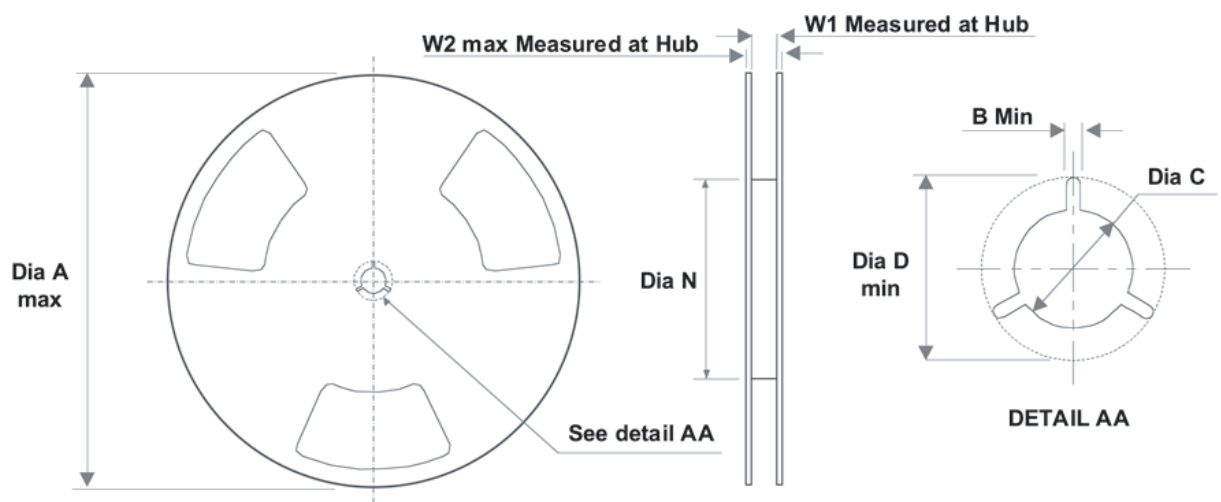

Tape Size	A	B	C	D	N	W1	W2
12mm	13.0 (330)	0.059 (1.50)	0.512 (13.00)	0.795 (20.20)	7.008 (178)	0.488 (12.4)	0.724 (18.4)

Physical Dimensions millimeters unless otherwise noted

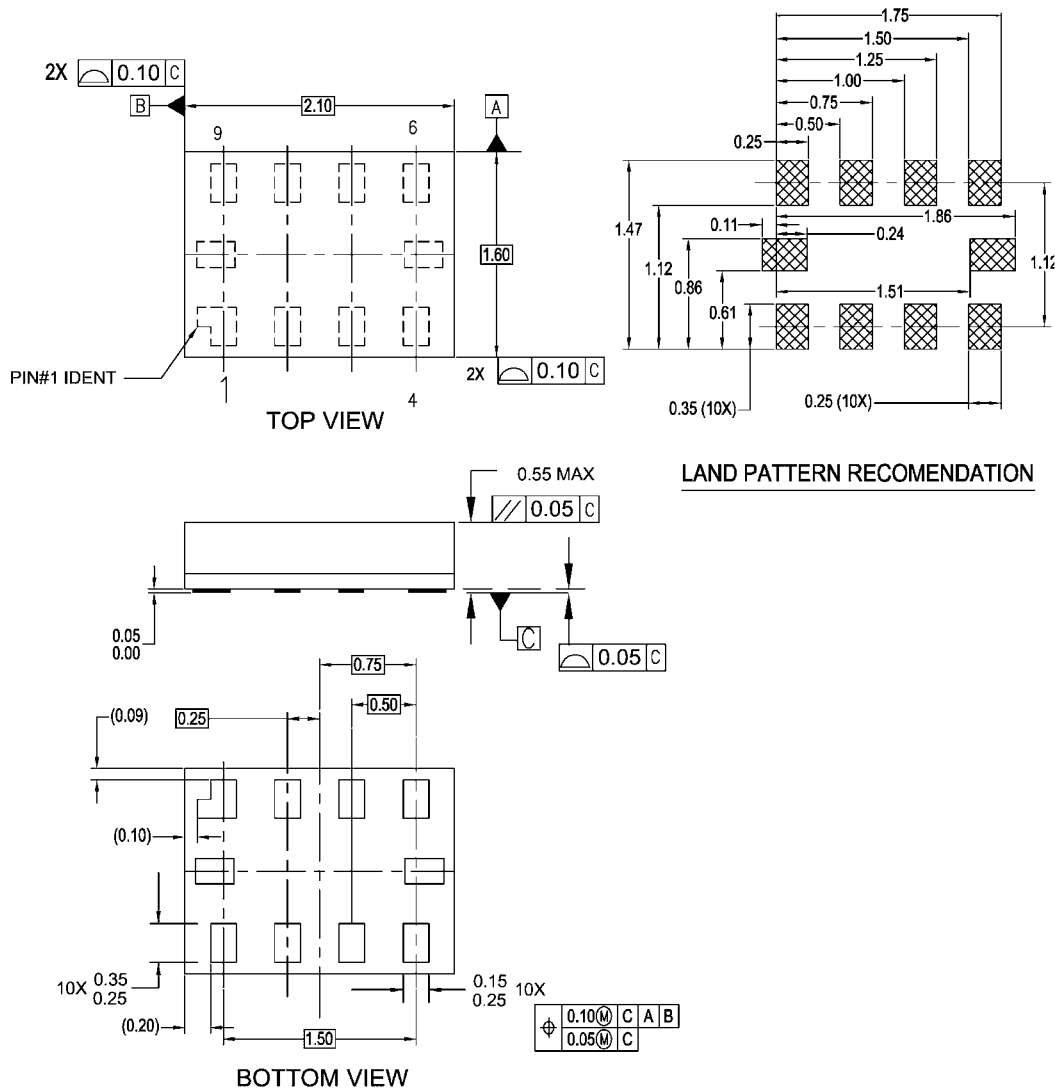

- NOTES:**
- A. PACKAGE CONFORMS TO JEDEC MO255, VARIATION UABD
 - B. DIMENSIONS ARE IN MILLIMETERS.
 - C. DIMENSIONS AND TOLERANCES CONFORMS TO ASME Y14.5M, 1994.

MAC010ARevC

**Pb-Free 10-Lead MicroPak, 1.6mm x 2.1mm
Package Number MAC010A**

Physical Dimensions millimeters unless otherwise noted

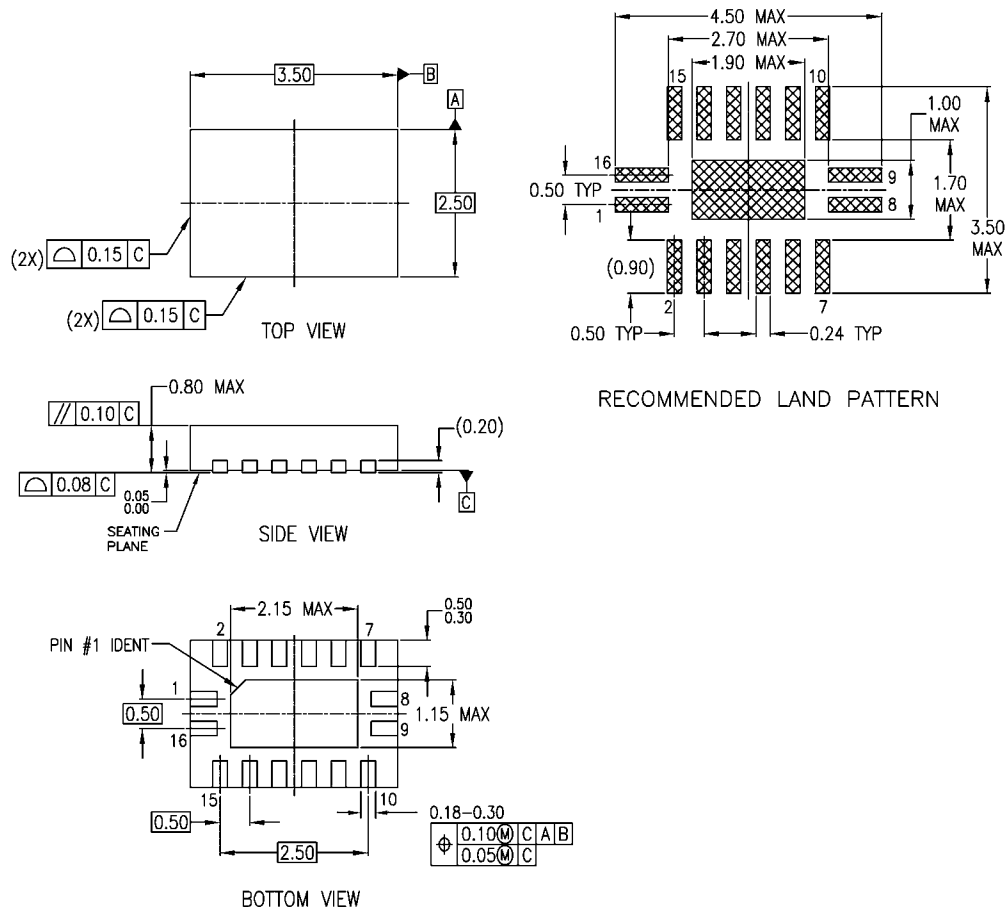

NOTES:

- A. CONFORMS TO JEDEC REGISTRATION MO-241, VARIATION AB
- B. DIMENSIONS ARE IN MILLIMETERS.
- C. DIMENSIONS AND TOLERANCES PER ASME Y14.5M, 1994

MLP016ErevA

Pb-Free 16-Terminal Depopulated Quad Very-Thin Flat Pack No Leads (DQFN), JEDEC MO-241, 2.5 x 3.5mm Package Number MLP016A

Physical Dimensions millimeters unless otherwise noted

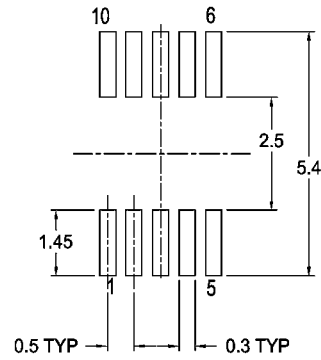
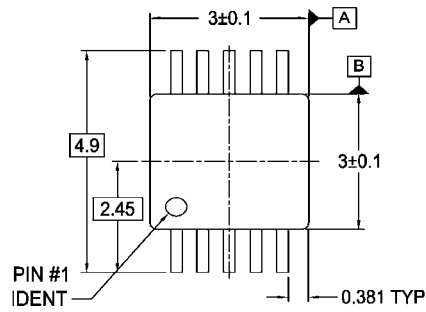

LAND PATTERN RECOMENDATION

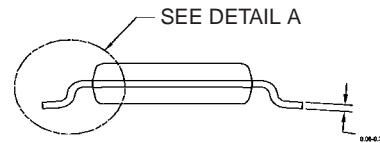
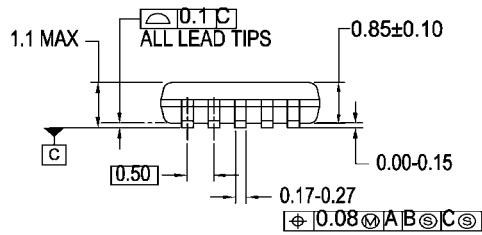

DIMENSIONS ARE IN MILLIMETERS

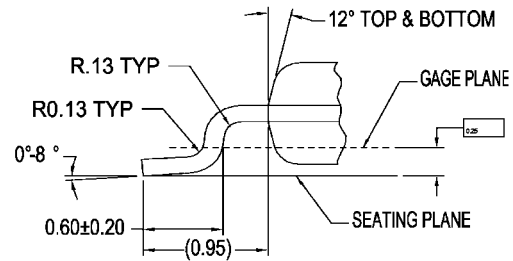

DETAIL A

NOTES:

- A. CONFORMS TO JEDEC REGISTRATION MO-187, VARIATION BA, REF NOTE 6, DATE 11/00.
- B. DIMENSIONS ARE IN MILLIMETERS.
- C. DIMENSIONS ARE EXCLUSIVE OF BURRS, MOLD FLASH, AND TIE BAR EXTRUSIONS.
- D. DIMENSIONS AND TOLERANCES PER ASME Y14.5M, 1994.

MUA10AREVA

Pb-Free 10-Lead Molded Small Outline Package (MSOP), JEDEC MO-187, 3.0mm Wide Package Number MUA10A

TRADEMARKS

The following are registered and unregistered trademarks Fairchild Semiconductor owns or is authorized to use and is not intended to be an exhaustive list of all such trademarks.

ACEx™	FAST®	ISOPLANAR™	PowerSaver™	SuperSOT™-6
ActiveArray™	FASTr™	LittleFET™	PowerTrench®	SuperSOT™-8
Bottomless™	FPS™	MICROCOUPLER™	QFET®	SyncFET™
Build it Now™	FRFET™	MicroFET™	QS™	TCM™
CoolFET™	GlobalOptoisolator™	MicroPak™	QT Optoelectronics™	TinyLogic®
CROSSVOLT™	GTO™	MICROWIRE™	Quiet Series™	TINYOPTO™
DOME™	HiSeC™	MSX™	RapidConfigure™	TruTranslation™
EcoSPARK™	I ² C™	MSXPro™	RapidConnect™	UHC™
E ² CMOS™	i-Lo™	OCX™	μSerDes™	UltraFET®
EnSigna™	ImpliedDisconnect™	OCXPro™	ScalarPump™	UniFET™
FACT™	IntelliMAX™	OPTOLOGIC®	SILENT SWITCHER®	VCX™
FACT Quiet Series™		OPTOPLANAR™	SMART START™	Wire™
		PACMAN™	SPM™	
Across the board. Around the world.™		POP™	Stealth™	
The Power Franchise®		Power247™	SuperFET™	
Programmable Active Droop™		PowerEdge™	SuperSOT™-3	

DISCLAIMER

FAIRCHILD SEMICONDUCTOR RESERVES THE RIGHT TO MAKE CHANGES WITHOUT FURTHER NOTICE TO ANY PRODUCTS HEREIN TO IMPROVE RELIABILITY, FUNCTION OR DESIGN. FAIRCHILD DOES NOT ASSUME ANY LIABILITY ARISING OUT OF THE APPLICATION OR USE OF ANY PRODUCT OR CIRCUIT DESCRIBED HEREIN; NEITHER DOES IT CONVEY ANY LICENSE UNDER ITS PATENT RIGHTS, NOR THE RIGHTS OF OTHERS.

LIFE SUPPORT POLICY

FAIRCHILD'S PRODUCTS ARE NOT AUTHORIZED FOR USE AS CRITICAL COMPONENTS IN LIFE SUPPORT DEVICES OR SYSTEMS WITHOUT THE EXPRESS WRITTEN APPROVAL OF FAIRCHILD SEMICONDUCTOR CORPORATION. As used herein:

1. Life support devices or systems are devices or systems which, (a) are intended for surgical implant into the body, or (b) support or sustain life, or (c) whose failure to perform when properly used in accordance with instructions for use provided in the labeling, can be reasonably expected to result in significant injury to the user.
2. A critical component is any component of a life support device or system whose failure to perform can be reasonably expected to cause the failure of the life support device or system, or to affect its safety or effectiveness.

PRODUCT STATUS DEFINITIONS

Definition of Terms

Datasheet Identification	Product Status	Definition
Advance Information	Formative or In Design	This datasheet contains the design specifications for product development. Specifications may change in any manner without notice.
Preliminary	First Production	This datasheet contains preliminary data, and supplementary data will be published at a later date. Fairchild Semiconductor reserves the right to make changes at any time without notice in order to improve design.
No Identification Needed	Full Production	This datasheet contains final specifications. Fairchild Semiconductor reserves the right to make changes at any time without notice in order to improve design.
Obsolete	Not In Production	This datasheet contains specifications on a product that has been discontinued by Fairchild semiconductor. The datasheet is printed for reference information only.

Rev. I18