

FSUSB11

Low-Power Full-Speed USB (12Mbps) Switch

Features

- Space saving MicroPak™ Pb-free packaging (1.6 x 2.1mm)
- USB 1.1 signal switching compliant
- -3db bandwidth: >350MHz
- Maximum 1.15Ω R_{ON} at 4.5V V_{CC} and 4Ω for 2.7V supply
- 0.3Ω maximum R_{ON} flatness for +5V supply
- Broad V_{CC} operating range: 1.65V to 5.5V
- Fast turn-on and turn-off time
- Break-before-make enable circuitry
- Over-voltage tolerant, TTL-compatible control input

Description

The FSUSB11 is a high-performance, dual Single-Pole Double-Throw (SPDT) switch designed for switching USB 1.1 signals. The device features ultra-low on resistance (R_{ON}) of 1.15Ω maximum at 4.5V V_{CC} and 4.3Ω at 2.7V supply. High bandwidth and ultra low (R_{ON}) make this switch able to pass both USB low- and full-speed signal with minimum signal distortion. The device is fabricated with sub-micron CMOS technology to achieve fast switching speeds and designed for break-before-make operation. The select input is TTL-level compatible.

Applications

- Cell Phone
- PDS
- Digital Camera
- Notebook

Ordering Information

Part Number	Package	Top Mark	Pb-Free	Packing Method
FSUSB11L10X	10-Lead MicroPak, 1.6 x 2.1mm	ET	Yes	5K units on tape and reel
FSUSB11MTCX	14-Lead Thin Shrink Small Outline Package (TSSOP), JEDEC MO-153, 4.4mm Wide	FSUSB11	Yes	2500 units on tape and reel
FSUSB11MUX (Preliminary)	10-Lead Molded Small Outline Package (MSOP), JEDEC MO-187, 3.0mm	FSUSB11	Yes	3K units on tape and reel

Pb-Free package per JEDEC J-STD-020B.

Block Diagram

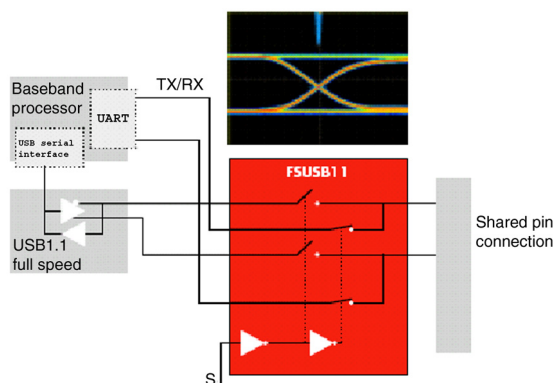

MicroPak™ is a trademark of Fairchild Semiconductor Corporation.

Connection Diagrams

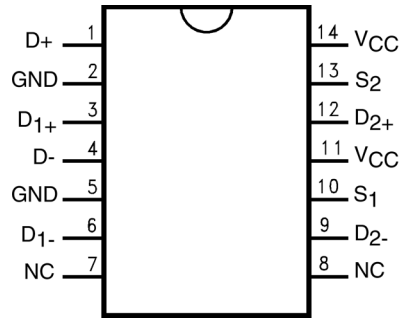

Figure 1. Pin Assignments for TSSOP (Top View)

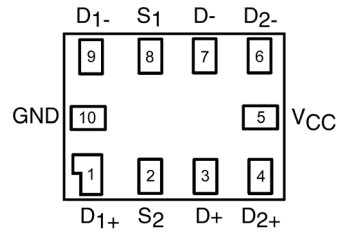

Figure 2. Pad Assignments for Micropak (Top View)

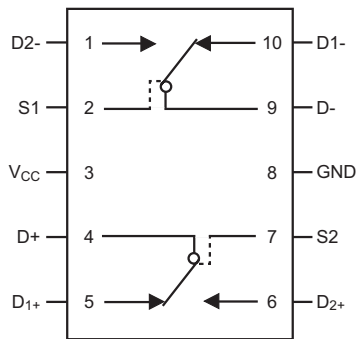

Figure 3. Pin Assignments for MSOP (Top Through View)

Analog Symbols

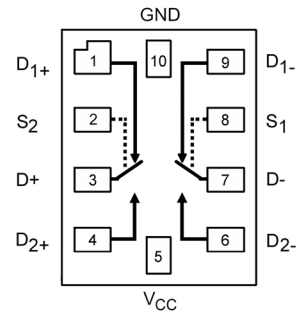

Figure 4. Analog Symbols (Top Through View)

Truth Table

Control Inputs	Function
Low Logic Level	D ₁ Connected to D+/D-
High Logic Level	D ₂ Connected to D+/D-

Pin Description

Pin names	Function
D, D ₁ , D ₂	Data Ports
S	Control Input

Absolute Maximum Ratings

The “Absolute Maximum Ratings” are those values beyond which the safety of the device cannot be guaranteed. The device should not be operated at these limits. The parametric values defined in the Electrical Characteristics tables are not guaranteed at the absolute maximum ratings. The “Recommended Operating Conditions” table defines the conditions for actual device operation.

Symbol	Parameter	Min.	Max.	Unit
V_{CC}	Supply Voltage ⁽¹⁾	-0.5	+6.0	V
V_S	Switch Voltage ⁽¹⁾	-0.5	V_{CC} to +0.5	V
V_{IN}	Input Voltage	-0.5	+6.0	V
I_{IK}	Input Diode Current	-50		mA
I_{SW}	Switch Current		200	mA
I_{SWPEAK}	Peak Switch Current (Pulsed at 1ms Duration, <10% Duty Cycle)		400	
T_{STG}	Storage Temperature Range	-65	+150	°C
T_J	Maximum Junction Temperature		+150	°C
T_L	Lead Temperature (Soldering, 10 seconds)		+260	°C
ESD	Human Body Model		8000	V

Notes:

1. The input and output negative voltage ratings may be exceeded if the input and output diode current ratings are observed.

Recommended Operating Conditions

Symbol	Parameter	Min.	Max.	Unit
V_{CC}	Supply Voltage	1.65	5.50	V
V_{IN}	Control Input Voltage ⁽²⁾	0	V_{CC}	V_{CC}
V_{SW}	Switch Input Voltage	0	V_{CC}	V_{CC}
T_A	Operating Temperature	-40	+85	°C

Notes:

2. Unused inputs must be held HIGH or LOW. They may not float.

DC Electrical Characteristics

All typical values are at 25°C unless otherwise specified.

Symbol	Parameter	Conditions	V _{CC} (V)	T _A = + 25 C°			T _A = -40 °C to +85 C°		Units
				Min.	Typ.	Max.	Min.	Max.	
V _{IH}	Input Voltage High		2.7 to 3.6				2.0		V
			4.5 to 5.5				2.4		
V _{IL}	Input Voltage Low		2.7 to 3.6					0.6	V
			4.5 to 5.5					0.8	
I _{IN}	Control Input Leakage	V _{IN} = 0V to V _{CC}	2.7 to 3.6				-1.0	1.0	μA
			4.5 to 5.5				-1.0	1.0	
I _{NO(OFF)} , I _{NC(OFF)}	Off-Leakage Current of Port D ₁ and D ₂	A = 1V, 4.5V, B ₀ or B ₁ = 1V, 4.5V	5.5	-50.0		50.0	-100	100	nA
I _{A(ON)}	On-Leakage Current of Port D	A = 1V, 4.5V, B ₀ or B ₁ = 1V, 4.5V or Floating	5.5	50.0		50.0	-100	100	nA
R _{ON}	Switch On Resistance MicroPak ⁽³⁾	I _{OUT} = 100mA, D ₁ or D ₂ = 1.5V	2.7		2.6	4.0		4.3	Ω
		I _{OUT} = 100 mA, D ₁ or D ₂ = 3.5V	4.50		0.95	1.15		1.30	
	Switch On Resistance TSSOP ⁽³⁾	I _{OUT} = 100mA, D ₁ or D ₂ = 1.5V	2.7		2.8			4.5	
		I _{OUT} = 100mA, D ₁ or D ₂ = 3.5V	4.5		1.5			3.0	
ΔR _{ON}	On Resistance Matching Between Channels MicroPak ⁽⁴⁾	I _{OUT} = 100mA, D ₁ or D ₂ = 3.5V	4.50		0.06	0.12		0.15	Ω
	On Resistance Matching Between Channels TSSOP ⁽⁴⁾	I _{OUT} = 100mA, D ₁ or D ₂ = 3.5V	4.50		0.07			0.30	
R _{FLAT(ON)}	On Resistance Flatness ⁽⁵⁾	I _{OUT} = 100mA, D ₁ or D ₂ = 0V, 0.75V, 1.5V	2.7		1.4				Ω
		I _{OUT} = 100mA, B ₀ or B ₁ = 0V, 1V, 2V	4.5		0.2	0.3		0.4	
I _{CC}	Quiescent Supply Current	V _{IN} = 0V or V _{CC} , I _{OUT} = 0V	3.6		0.1	0.5		1.0	μA
			5.5		0.1	0.5		1.0	

Notes:

- On resistance is determined by the voltage drop between D and D_n pins at the indicated current through the switch.
- ΔR_{ON} = R_{ONmax} - R_{ONmin} measured at identical V_{CC}, temperature, and voltage.
- Flatness is defined as the difference between the maximum and minimum value of on resistance over the specified range of conditions.

AC Electrical Characteristics (Continued)

All typical values are at 25°C unless otherwise specified.

Symbol	Parameter	Conditions	V _{CC} (V)	T _A = +25 C°			T _A = -40 C° to +85 C°		Units	Figure Number
				Min.	Typ.	Max.	Min.	Max.		
t _{ON}	Turn-ON Time	D ₁ or D ₂ = 1.5V, R _L = 50Ω, C _L = 35 pF	2.7 to 3.6			50.0		60.0	ns	Figure 5
		D ₁ or D ₂ = 3.0V, R _L = 50Ω, C _L = 35 pF	4.5 to 5.5			35.0		40.0		
t _{OFF}	Turn-OFF Time	D ₁ or D ₂ = 1.5V, R _L = 50Ω, C _L = 35 pF	2.7 to 3.6			20.0		30.0	ns	Figure 5
		D ₁ or D ₂ = 3.0V, R _L = 50Ω, C _L = 35 pF	4.5 to 5.5			15.0		20.0		
t _{BMM}	Break-Before-Make Time	D ₁ or D ₂ = 1.5V, R _L = 50Ω, C _L = 35 pF	2.7 to 3.6				1.0		ns	Figure 6
		D ₁ or D ₂ = 3.0V, R _L = 50Ω, C _L = 35 pF	4.5 to 5.5		20.0		1.0			
Q	Charge Injection	C _L = 1.0 nF, V _{GEN} = 0V, R _{GEN} = 0Ω	2.7 to 3.6		20.0				pC	Figure 8
			4.5 to 5.5		10.0					
OIRR	OFF-Isolation	f = 1MHz, R _L = 50Ω	2.7 to 3.6		-70.0				dB	Figure 7
			4.5 to 5.5		-70.0					
X _{talk}	Crosstalk	f = 1MHz, R _L = 50Ω	2.7 to 3.6		-75.0				dB	Figure 7
			4.5 to 5.5		-75.0					
BW	-3db Bandwidth	R _L = 50Ω	2.7 to 3.6		350				MHz	Figure 10
			4.5 to 5.5		350					

USB Related AC Electrical Characteristics

All typical values are at 25°C unless otherwise specified.

Symbol	Parameter	Conditions	V _{CC} (V)	T _A = +25° C			Units	Figure Number
				Min.	Typ.	Min.		
t _{SKEW}	Skew	R _S = 39, C _L = 50 pF, t _R = t _F = 12ns at 12Mbps	2.7 to 3.6		0.15		ns	Figure 11
			4.5 to 5.5		0.15			
t _M	Rising/Fall Time Mismatch	(Duty Cycle = 50%)	2.7 to 3.6			10.0	%	Figure 12
			4.5 to 5.5			10.0		
t _J	Total Jitter	R _S = 39, C _L = 50 pF, t _R = t _F = 12ns at 12Mbps (PRBS = 2 ¹⁵ - 1)	2.7 to 3.6		1.7		ns	Figure 11
			4.5 to 5.5		1.6			

Capacitance

Symbol	Parameter	Conditions	V _{CC} (V)	T _A = +25 C°			Units	Figure Number
				Min.	Typ.	Max.		
C _{IN}	Control Pin Input Capacitance	f = 1MHz	0.0		3.5		pF	Figure 9
C _{OFF}	D _n Port OFF Capacitance	f = 1MHz	4.5		12.0		pF	Figure 9
C _{ON}	D Port ON Capacitance	f = 1MHz	4.5		40.0		pF	Figure 9

AC Loading and Waveforms

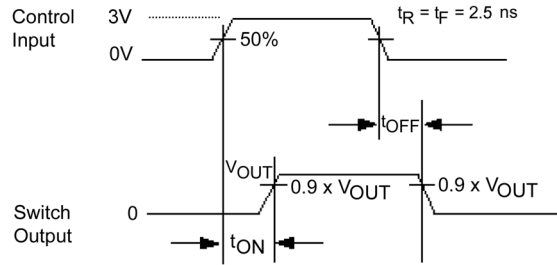
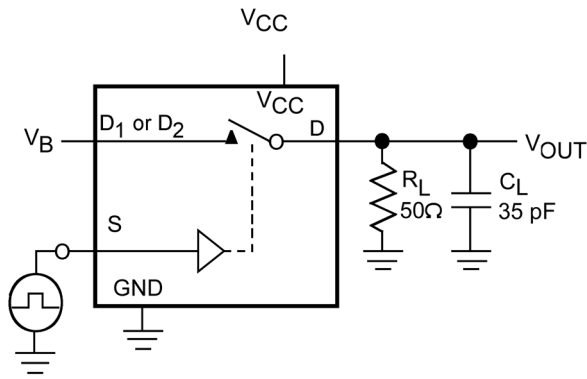

C_L includes Fixture and Stray Capacitance

Logic Input Waveforms Inverted for Switches that have the Opposite Logic Sense

Figure 5. Turn-On/Turn-Off Timing

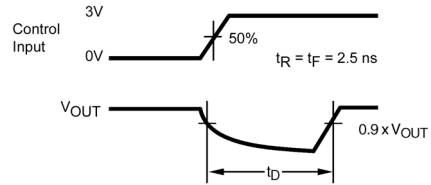
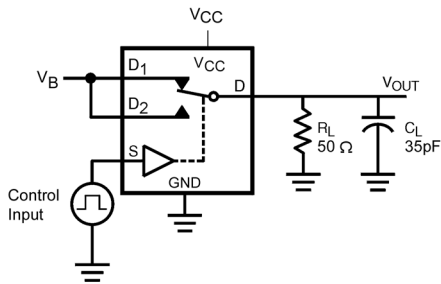

C_L Includes Fixture and Stray Capacitance

Figure 6. Break-Before-Make Timing

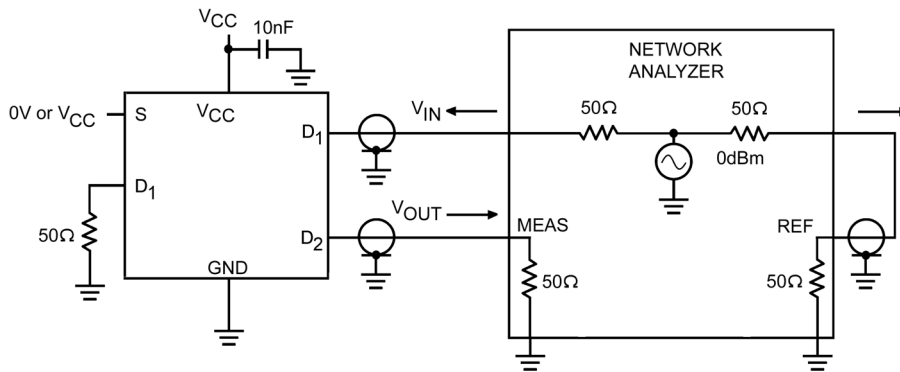

$$\text{OFF-ISOLATION} = 20 \log \frac{V_{OUT}}{V_{IN}}$$

$$\text{ON-LOSS} = 20 \log \frac{V_{OUT}}{V_{IN}}$$

$$\text{CROSSTALK} = 20 \log \frac{V_{OUT}}{V_{IN}}$$

Figure 7. OFF Isolation and Crosstalk

AC Loading and Waveforms (Continued)

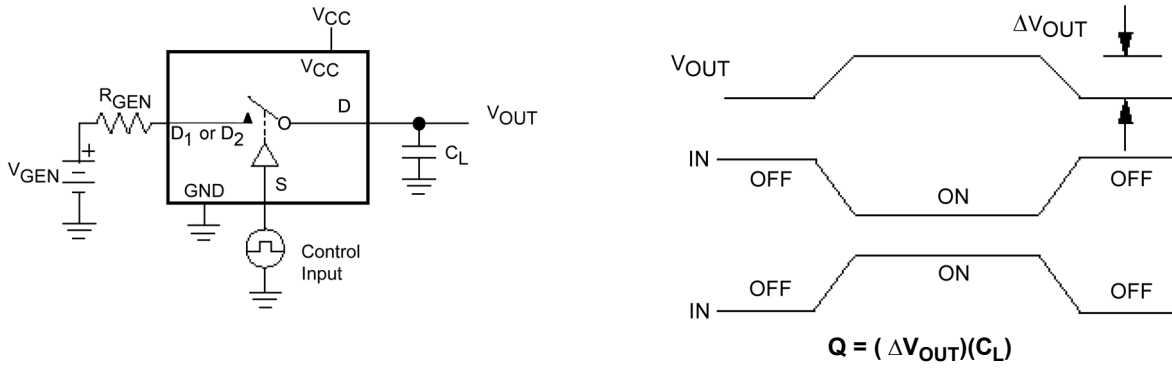

Figure 8. Charge Injection

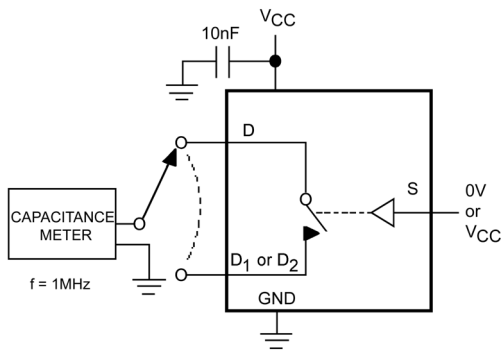

Figure 9. ON / OFF Capacitance Measurement Setup

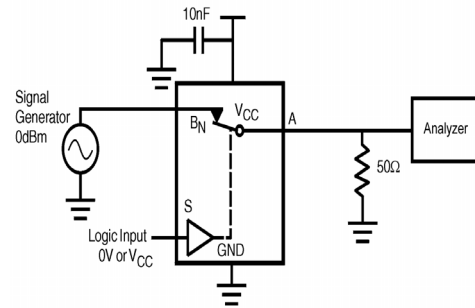

Figure 10. Bandwidth

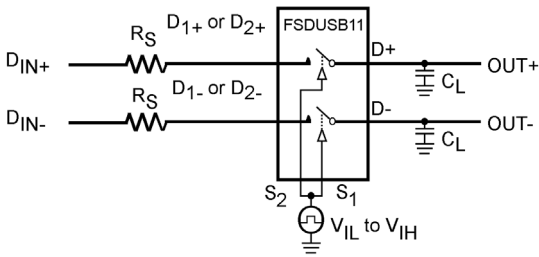

Figure 11. Skew Test

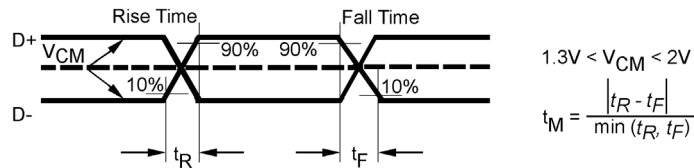
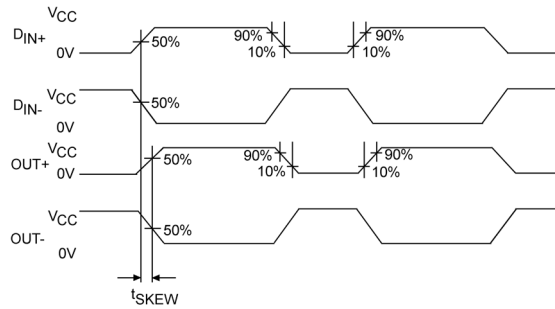
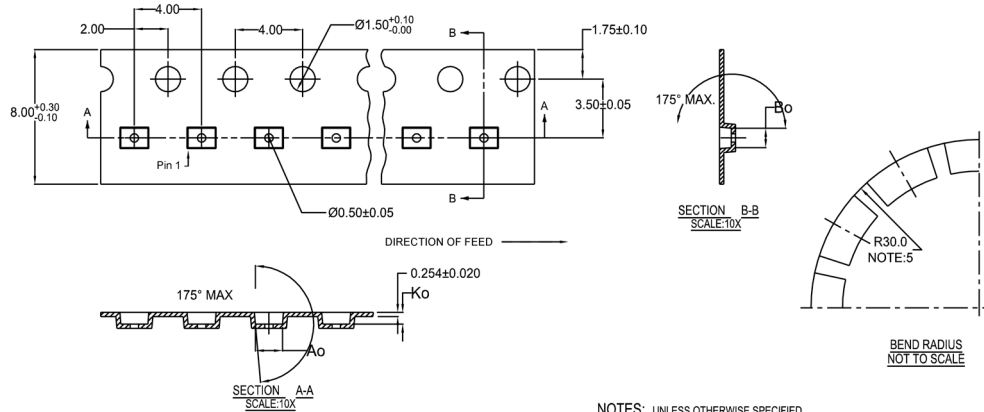

Figure 12. Rise / Fall Time Mismatch Test

Tape and Reel Specification

Tape Format for Micropak 10

Package Designator	Tape Section	Number Cavities	Cavity Status	Cover Tape Status
	Leader (Start End)	125 (typ)	Empty	Sealed
L10X	Carrier	5000	Filled	Sealed
	Trailer (Hub End)	75 (typ)	Empty	Sealed



10	300056	2.30±0.05	1.78±0.05	0.68±0.05
8	300038	1.78±0.05	1.78±0.05	0.68±0.05
6	300033	1.60±0.05	1.15±0.05	0.70±0.05

NOTES: UNLESS OTHERWISE SPECIFIED

1. ACCUMULATED 50 SPROCKETS, SPROCKET HOLE PITCH IS 200.00 ±0.30MM
2. NO INDICATED CORNER RADIUS IS 0.127MM
3. CAMBER NOT TO EXCEED 1MM IN 100MM
4. SMALLEST ALLOWABLE BENDING RADIUS
5. POCKET POSITION RELATIVE TO SPROCKET HOLE MEASURED AS TRUE POSITION OF POCKET, NOT POCKET HOLE



SCALE: 6X

Reel Dimensions

Dimensions are in inches (millimeters) unless otherwise noted.

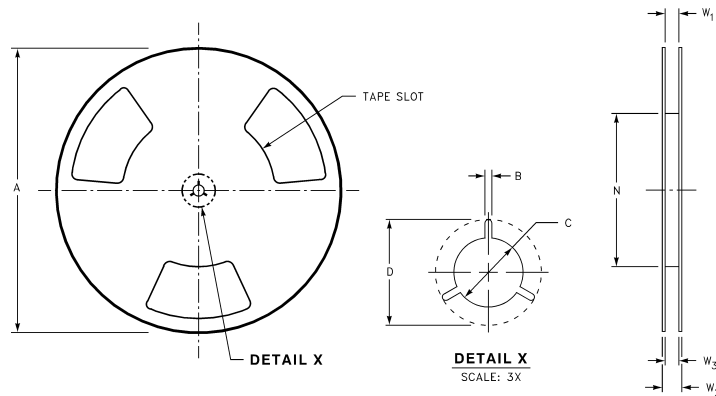

Tape Size	A	B	C	D	N	W1	W2	W3
(8mm)	7.0 (177.8)	0.059 (1.50)	0.512 (13.00)	0.795 (20.20)	2.165 (55.00)	0.331 + 0.059/-0.000 (8.40 + 1.50/-0.00)	0.567 (14.40)	W1 + 0.078/-0.039 (W1 + 2.00/-1.00)

Tape Dimensions for MSOP

Dimensions are in millimeters (inches) unless otherwise specified.

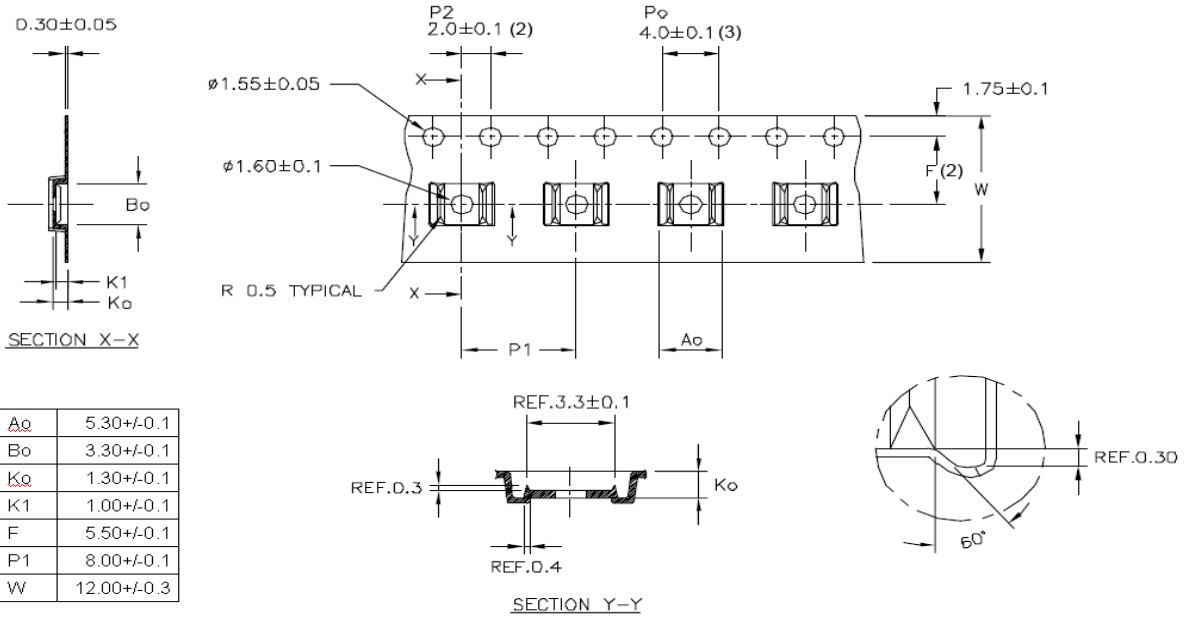

Notes:

1. All dimensions are in millimeters.
2. Measured from centerline of sprocket hole to centerline of pocket.
3. Cumulative tolerance of ten sprocket holes is ±0.20mm.
4. Other material available.

Reel Dimensions for MSOP

Dimensions are in inches (millimeters) unless otherwise specified.

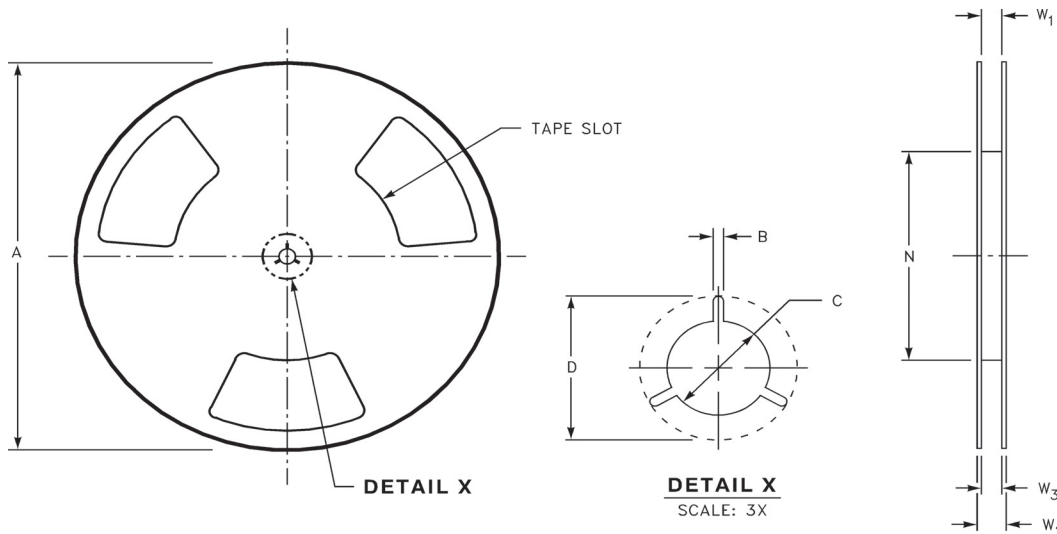

Tape Size	A	B	C	D	N	W1	W2	W3
(12mm)	13 (330)	0.059 (1.5)	0.512 (13)	0.795 (20.2)	7.008 (178)	0.448 (12.4)	0.724 (18.4)	0.468-0.606 (11.9 -15.4)

Physical Dimension

Dimensions are in millimeters (inches) unless otherwise noted.

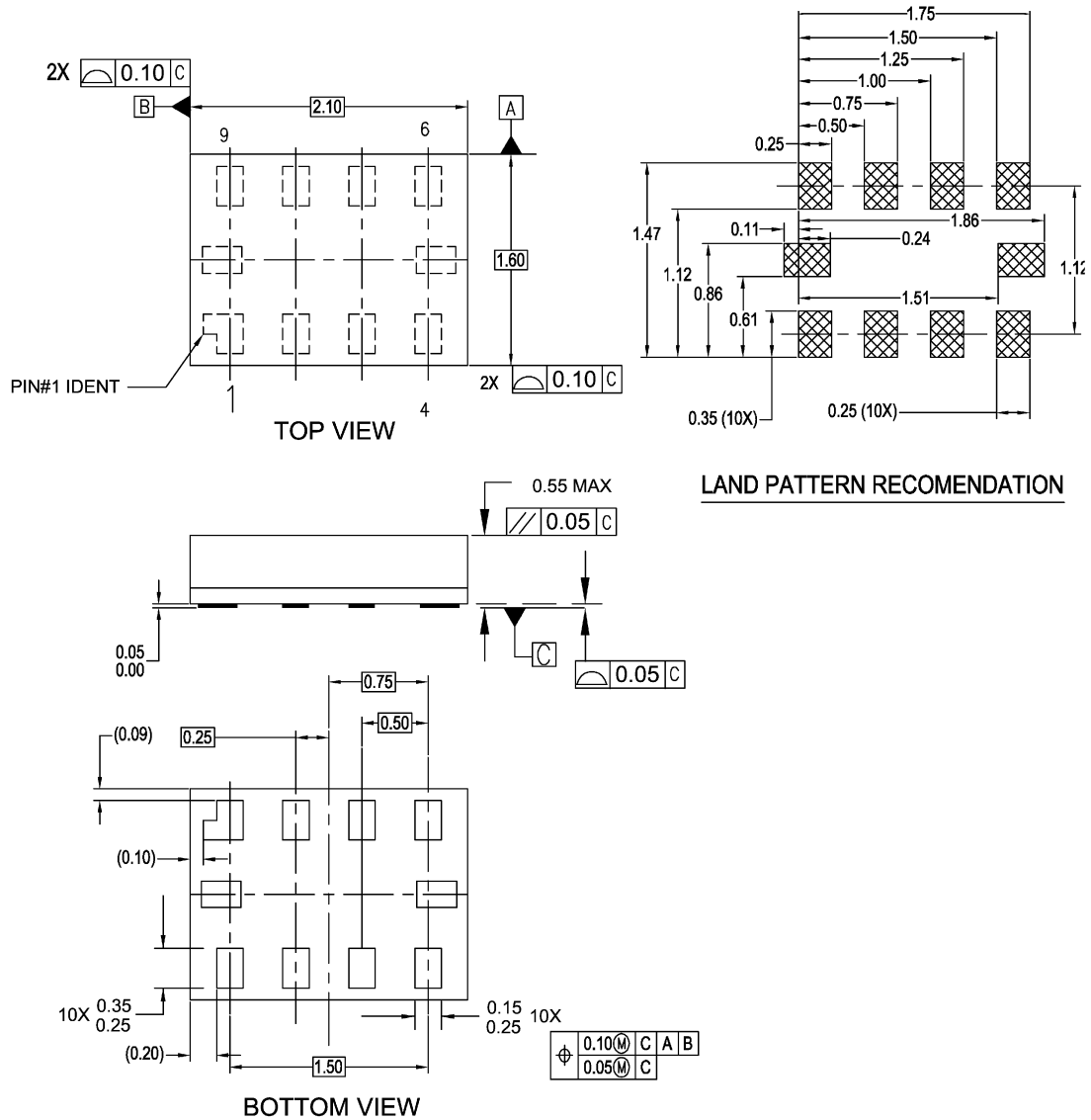

NOTES:

- A. PACKAGE CONFORMS TO JEDEC MO255, VARIATION UABD
- B. DIMENSIONS ARE IN MILLIMETERS.
- C. DIMENSIONS AND TOLERANCES CONFORMS TO ASME Y14.5M, 1994.

MAC010ARevC

Figure 13. Pb-Free 10-Lead MicroPak, 1.6 x 2.1mm

Physical Dimension (Continued)

Dimensions are in millimeters (inches) unless otherwise noted.

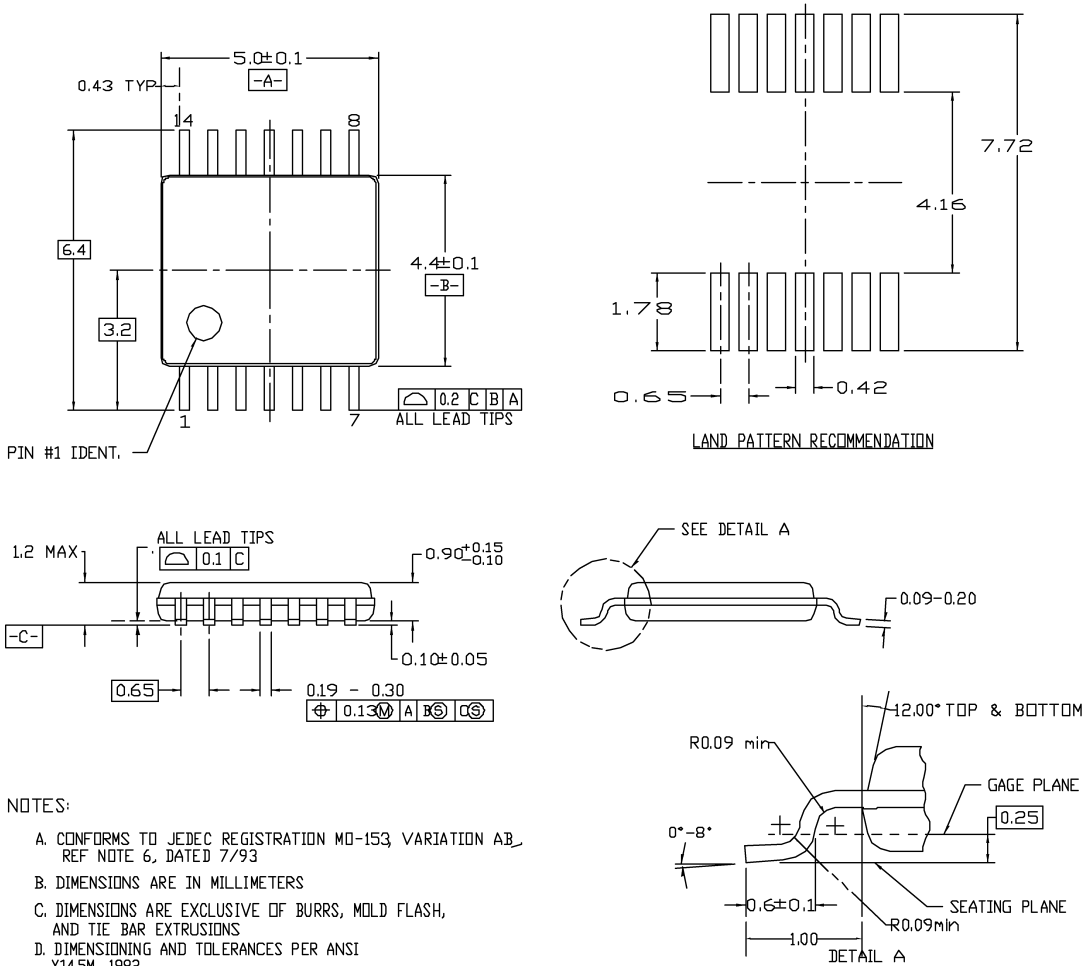
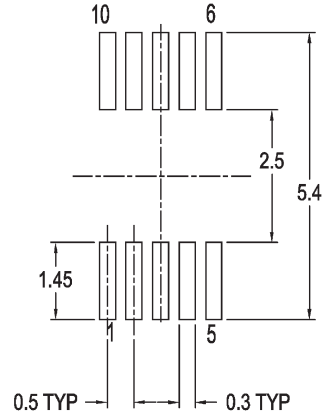
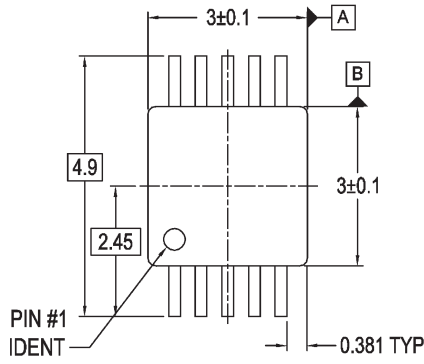

Figure 14. 14-Lead Thin-Shrink Small Outline Package (TSSOP), JEDEC MO-153, 4.4mm Wide

Physical Dimension (Continued)

Dimensions are in millimeters (inches) unless otherwise noted.



LAND PATTERN RECOMENDATION

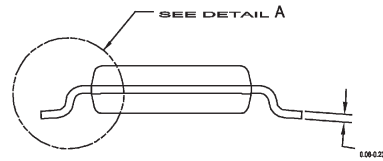
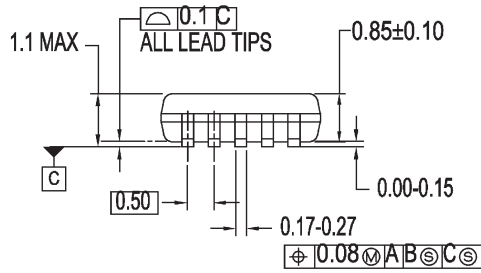

DIMENSIONS ARE IN MILLIMETERS

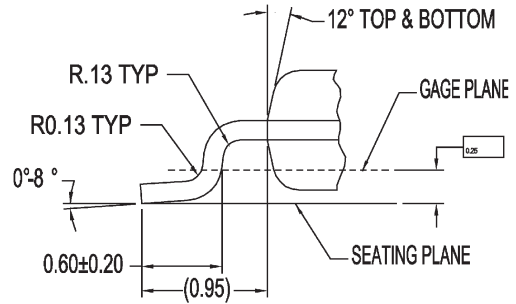

DETAIL A

NOTES:

- A. CONFORMS TO JEDEC REGISTRATION MO-187, VARIATION BA, REF NOTE 6, DATE 11/00.
- B. DIMENSIONS ARE IN MILLIMETERS.
- C. DIMENSIONS ARE EXCLUSIVE OF BURRS, MOLD FLASH, AND TIE BAR EXTRUSIONS.
- D. DIMENSIONS AND TOLERANCES PER ASME Y14.5M, 1994.

MUA10AREVA

Figure 15. 10-Lead Molded Small Outline Package (MSOP), JEDEC MO-187, 3.0mm

TRADEMARKS

The following are registered and unregistered trademarks Fairchild Semiconductor owns or is authorized to use and is not intended to be an exhaustive list of all such trademarks.

ACEx™	FACT Quiet Series™	OCX™	SILENT SWITCHER®	UniFET™
ActiveArray™	GlobalOptoisolator™	OCXPro™	SMART START™	UltraFET®
Bottomless™	GTO™	OPTOLOGIC®	SPM™	VCX™
Build it Now™	HiSeC™	OPTOPLANAR™	Stealth™	Wire™
CoolFET™	I ² C™	PACMAN™	SuperFET™	
CROSSVOLT™	i-Lo™	POP™	SuperSOT™_3	
DOVE™	ImpliedDisconnect™	Power247™	SuperSOT™_6	
EcoSPARK™	IntelliMAX™	PowerEdge™	SuperSOT™_8	
E ² C MOS™	ISOPLANAR™	PowerSaver™	SyncFET™	
EnSigna™	LittleFET™	PowerTrench®	TCM™	
FACT™	MICROCOUPLER™	QFET®	TinyBoost™	
FAST®	MicroFET™	QS™	TinyBuck™	
FASTr™	MicroPak™	QT Optoelectronics™	TinyPWM™	
FPS™	MICROWIRE™	Quiet Series™	TinyPower™	
FRFET™	MSX™	RapidConfigure™	TinyLogic®	
	MSXPro™	RapidConnect™	TINYOPTO™	
Across the board. Around the world.™		μSerDes™	TruTranslation™	
The Power Franchise®		ScalarPump™	UHC®	
Programmable Active Droop™				

DISCLAIMER

FAIRCHILD SEMICONDUCTOR RESERVES THE RIGHT TO MAKE CHANGES WITHOUT FURTHER NOTICE TO ANY PRODUCTS HEREIN TO IMPROVE RELIABILITY, FUNCTION, OR DESIGN. FAIRCHILD DOES NOT ASSUME ANY LIABILITY ARISING OUT OF THE APPLICATION OR USE OF ANY PRODUCT OR CIRCUIT DESCRIBED HEREIN; NEITHER DOES IT CONVEY ANY LICENSE UNDER ITS PATENT RIGHTS, NOR THE RIGHTS OF OTHERS. THESE SPECIFICATIONS DO NOT EXPAND THE TERMS OF FAIRCHILD'S WORLDWIDE TERMS AND CONDITIONS, SPECIFICALLY THE WARRANTY THEREIN, WHICH COVERS THESE PRODUCTS.

LIFE SUPPORT POLICY

FAIRCHILD'S PRODUCTS ARE NOT AUTHORIZED FOR USE AS CRITICAL COMPONENTS IN LIFE SUPPORT DEVICES OR SYSTEMS WITHOUT THE EXPRESS WRITTEN APPROVAL OF FAIRCHILD SEMICONDUCTOR CORPORATION.

As used herein:

1. Life support devices or systems are devices or systems which, (a) are intended for surgical implant into the body, or (b) support or sustain life, or (c) whose failure to perform when properly used in accordance with instructions for use provided in the labeling, can be reasonably expected to result in significant injury to the user.
2. A critical component is any component of a life support device or system whose failure to perform can be reasonably expected to cause the failure of the life support device or system, or to affect its safety or effectiveness.

PRODUCT STATUS DEFINITIONS

Definition of Terms

Datasheet Identification	Product Status	Definition
Advance Information	Formative or In Design	This datasheet contains the design specifications for product development. Specifications may change in any manner without notice.
Preliminary	First Production	This datasheet contains preliminary data, and supplementary data will be published at a later date. Fairchild Semiconductor reserves the right to make changes at any time without notice to improve design.
No Identification Needed	Full Production	This datasheet contains final specifications. Fairchild Semiconductor reserves the right to make changes at any time without notice to improve design.
Obsolete	Not In Production	This datasheet contains specifications on a product that has been discontinued by Fairchild semiconductor. The datasheet is printed for reference information only.

Rev. I21