



FSA4159

Low-Voltage, 1Ω SPDT Analog Switch with Power-Off Isolation

Features

- Low I_{CC} When the S Input is Lower Than V_{CC}
- Power-Off Isolation ($V_{CC}=0V$)
- 1Ω On Resistance (R_{ON}) for 4.5V V_{CC}
- 0.25Ω Maximum R_{ON} Flatness for 4.5V V_{CC}
- Space-Saving, Pb-Free, 6-Lead SC70 Surface Mount Package
- Broad V_{CC} Operating Range: 1.65V to 5.50V
- Fast Turn-On and Turn-Of Times
- Break-Before-Make Enable Circuitry
- Pb-Free “Green” Packaging

Description

The FSA4159 is a high-performance Single-Pole / Double-Throw (SPDT) analog switch. The device features ultra-low R_{ON} of 1Ω at 4.5V V_{CC} and operates over the wide V_{CC} range of 1.65V to 5.50V. The device is fabricated with sub-micron CMOS technology to achieve fast switching speeds and is designed for break-before-make operation.

The FSA4159 features very low quiescent current even when the control voltage is lower than the V_{CC} supply. This feature services mobile handset applications by allowing direct interface with baseband processor general-purpose I/Os.

Applications

- Cellular Phone
- Portable Media Player
- PDA

Ordering Information

Part Number	Operating Temperature Range	Package	Packing Method
FSA4159P6X	-40°C to +85°C	6-Lead SC70, EIAJ SC88, 1.25mm Wide	3000 Units on Tape and Reel
FSA4159L6X	-40°C to +85°C	6-Lead Micropak™, 1.00mm Wide	5000 Units on Tape and Reel

All packages are lead free per JEDEC: J-STD-020B standard.

Micropak™ is a trademark of Fairchild Semiconductor Corporation.

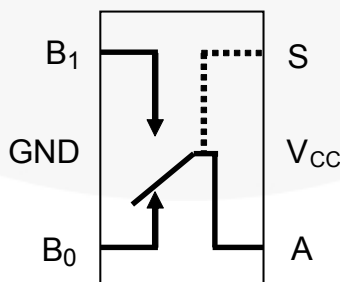

Figure 1. Analog Symbols

Pin Configuration

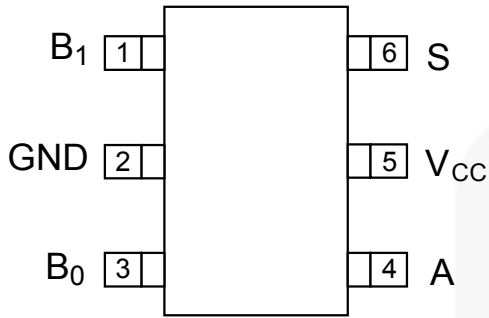

Figure 2. SC70 Pin Assignments (Top View)

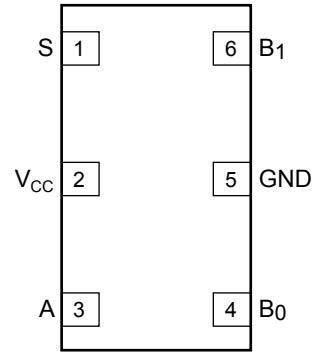

Figure 3. Micropak™ Pin Assignment (Top View)

Pin Definitions

Pin# SC70	Pin# Micropak™	Name	Description
1	6	B1	Data Ports
2	5	GND	Ground
3	4	B0	Data Ports
4	3	A	Data Ports
5	2	V _{CC}	Supply Voltage
6	1	S	Control Input

Truth Table

Control Input (S)	Function
Low	B0 connected to A
High	B1 connected to A

Absolute Maximum Ratings

Stresses exceeding the absolute maximum ratings may damage the device. The device may not function or be operable above the recommended operating conditions and stressing the parts to these levels is not recommended. In addition, extended exposure to stresses above the recommended operating conditions may affect device reliability. The absolute maximum ratings are stress ratings only.

Symbol	Parameter	Min.	Max.	Unit
V_{CC}	Supply Voltage	-0.5	6.5	V
V_{SW}	Switch Voltage ⁽¹⁾	-0.5	$V_{CC} + 0.5$	V
V_{IN}	Input Voltage ⁽¹⁾	-0.5	6.5	V
I_{IK}	Input Diode Current		-50	mA
I_{SW}	Switch Current (Continuous)		200	mA
I_{SWPEAK}	Peak Switch Current (Pulsed at 1ms Duration, <10% Duty Cycle)		400	mA
P_D	Power Dissipation at 85°C		180	mW
T_{STG}	Storage Temperature Range	-65	+150	°C
T_J	Max Junction Temperature		+150	°C
T_L	Lead Temperature (Soldering, 10 Seconds)		+260	°C
ESD	Human Body Model (JEDEC: JESD22-A114)		4000	V
	Charged Device Model (JEDEC: JESD22-C101)		1500	
	Machine Model (JEDEC: JESD22-A115)		200	

Note:

- The input and output negative ratings may be exceeded if the input and output diode current ratings are observed.

Recommended Operating Conditions

The Recommended Operating Conditions table defines the conditions for actual device operation. Recommended operating conditions are specified to ensure optimal performance to the datasheet specifications. Fairchild does not recommend exceeding them or designing to Absolute Maximum Ratings.

Symbol	Parameter	Min.	Max.	Unit
V_{CC}	Supply Voltage	1.65	5.50	V
A_{SEL}	Control Input Voltage ⁽²⁾	0	V_{CC}	V
V_{SW}	Switch Input Voltage	0	V_{CC}	V
T_A	Operating Temperature	-40	+85	°C
θ_{JA}	Thermal Resistance, Still Air		350	°C/W

Note:

- Control Input must be held HIGH or LOW; it must not float.

Electrical Characteristics

All typical values are at 25°C unless otherwise specified.

Symbol	Parameter	V _{CC} (V)	Conditions	T _A =+25°C			T _A =-40 to +85°C		Unit
				Min.	Typ.	Max.	Min.	Max.	
V _{IH}	Input Voltage High	4.50 to 5.50					2.4		V
		3.00 to 3.60					2.4		
		2.30 to 2.70					1.8		
		1.65 to 1.95					1.5		
V _{IL}	Input Voltage Low	4.50 to 5.50						0.8	V
		3.00 to 3.60					0.8		
		2.30 to 2.70					0.6		
		1.65 to 1.95					0.6		
I _{IN}	Control Input Leakage	5.50	V _{IN} =0 or V _{CC}	-2		2	-100	100	nA
		3.60	V _{IN} =0 or V _{CC}	-2		2	-100	100	
		2.70	V _{IN} =0 or V _{CC}	-2		2	-20	20	
		1.95	V _{IN} =0 or V _{CC}	-2		2	-20	20	
I _{NO(OFF)} , I _{NC(OFF)}	Off-Leakage Current of Port B ₀ and B ₁	5.50	A=1V, 4.5V B ₀ or B ₁ =4.5, 1.0V	-10		10	-50	50	nA
		3.60	A=1V, 3.0V B ₀ or B ₁ =3.0, 1.0V	-10		10	-50	50	
		2.70	A=0.5V, 2.3V B ₀ or B ₁ =2.3, 0.5V	-10		10	-50	50	
		1.95	A=0.3V, 1.65V B ₀ or B ₁ =1.65, 0.3V	-5		5	-20	20	
I _{NO(ON)} , I _{NC(ON)}	On-Leakage Current of Port B ₀ and B ₁	5.50	A=float B ₀ or B ₁ =4.5, 1.0V	-20		20	-100	100	nA
		3.60	A=float B ₀ or B ₁ =3.0, 1.0V	-10		10	-20	20	
		2.70	A=float B ₀ or B ₁ =2.3, 0.5V	-10		10	-20	20	
		1.95	A=float B ₀ or B ₁ =1.65, 0.3V	-5		5	-20	20	
I _{A(ON)}	On Leakage Current of Port A	5.50	A=1V, 4.5V B ₀ or B ₁ =1V, 4.5V, or floating	-20		20	-100	100	nA
		3.60	A=1V, 3.0V, B ₀ or B ₁ =1V, 3.0V, or floating	-10		10	-20	20	
		2.70	A=0.5V, 2.3V B ₀ or B ₁ =0.5V, 2.3V, or floating	-10		10	-20	20	
		1.95	A=0.3V, 1.65V B ₀ or B ₁ =0.3V, 1.65V, or floating	-5		5	-20	20	
I _{OFF}	Power Off Leakage Current of Port A & Port B	0	A=0 to V _{CC} B ₀ or B ₁ =0 to V _{CC}	-1.00	0.01	1.00	-5.00	5.00	μA

Continued on following page...

Electrical Characteristics (Continued)

All typical values are at 25°C unless otherwise specified.

Symbol	Parameter	V _{CC} (V)	Conditions	T _A =+25°C			T _A =-40 to +85°C		Unit
				Min.	Typ.	Max.	Min.	Max.	
R _{PEAK}	Peak On Resistance	4.50	I _{OUT} =-100mA, B ₀ or B ₁ =0 to V _{CC}		1.0	1.1		1.3	Ω
		3.00	I _{OUT} =-100mA, B ₀ or B ₁ =0 to V _{CC}		1.2	1.5		1.8	
		2.30	I _{OUT} =-8mA, B ₀ or B ₁ =0 to V _{CC}		1.5	2.0		2.5	
		1.65	I _{OUT} =2mA, B ₀ or B ₁ =0 to V _{CC}	T _A =25, 85°C T _A =-40°C		4.0	10.0		
R _{ON}	Switch On Resistance ⁽³⁾	4.50	I _{OUT} =-100mA, B ₀ or B ₁ =2.5V		0.8	0.9		1.1	Ω
		3.00	I _{OUT} =-100mA, B ₀ or B ₁ =2.0V		1.0	1.3		1.6	
		2.30	I _{OUT} =-8mA, B ₀ or B ₁ =1.8V		1.4	2.0		2.4	
		1.65	I _{OUT} =-2mA, B ₀ or B ₁ =1.5V		1.7	2.5		3.5	
Δ R _{ON}	On Resistance Matching Between Channels ⁽⁴⁾	4.50	I _{OUT} =-100mA, B ₀ or B ₁ =2.5V		0.05	0.10		0.10	Ω
		3.00	I _{OUT} =-100mA, B ₀ or B ₁ =2.0V		0.10	0.15		0.15	
		2.30	I _{OUT} =-8mA, B ₀ or B ₁ =1.8V		0.15	0.20		0.20	
		1.65	I _{OUT} =-2mA, B ₀ or B ₁ =1.5V		0.15	0.40		0.40	
R _{FLAT(ON)}	On Resistance Flatness ⁽⁵⁾	4.50	I _{OUT} =-100mA, B ₀ or B ₁ =1.0V, 1.5V, 2.5V		0.075	0.250		0.250	Ω
		3.00	I _{OUT} =-100mA, B ₀ or B ₁ =0.8V, 2.0V		0.1	0.3		0.3	
		2.30	I _{OUT} =-8mA, B ₀ or B ₁ =0.8V, 1.8V		0.2	1.0		1.0	
		1.65	I _{OUT} =-2mA, B ₀ or B ₁ =0.6V, 1.5V		3.5				
I _{CC}	Quiescent Supply Current	5.50	V _{IN} =0 or V _{CC} , I _{OUT} =0		10.0	50.0		500.0	nA
		3.60	V _{IN} =0 or V _{CC} , I _{OUT} =0		1.0	25.0		100.0	
		2.70	V _{IN} =0 or V _{CC} , I _{OUT} =0		0.5	20.0		50.0	
		1.95	V _{IN} =0 or V _{CC} , I _{OUT} =0		0.5	15.0		50.0	

Notes:

3. On resistance is determined by the voltage drop between A and B pins at the indicated current through the switch.
4. Δ R_{ON}=R_{ON} maximum – R_{ON} minimum measured at identical V_{CC}, temperature and voltage.
5. Flatness is defined as the difference between the maximum and minimum value of on resistance over the specified range of conditions.

AC Electrical Characteristics

All typical value are at $V_{CC}=1.8V, 2.5V, 3.0V, 5.0V$ at $25^{\circ}C$ unless otherwise specified.

Symbol	Parameter	V_{CC} (V)	Conditions	$T_A=+25^{\circ}C$			$T_A=-40to+85^{\circ}C$		Unit	Figure
				Min.	Typ.	Max.	Min.	Max.		
t_{ON}	Turn-On Time	4.50 to 5.50	B_0 or $B_1=V_{CC}$, $R_L=50\Omega$, $C_L=35pF$	1	16	30	1	35	ns	Figure 11
		3.00 to 3.60		5	21	35	3	50		
		2.30 to 2.70		5	28	40	5	50		
		1.65 to 1.95		10	50	70	10	75		
t_{OFF}	Turn-Off Time	4.50 to 5.50	B_0 or $B_1=V_{CC}$, $R_L=50\Omega$, $C_L=35pF$	1	13	20	1	30	ns	Figure 11
		3.00 to 3.60		1	15	20	1	30		
		2.30 to 2.70		2	20	35	2	50		
		1.65 to 1.95		2.0	28	40	2	50		
t_{BBM}	Break-Before-Make Time	4.50 to 5.50	B_0 or $B_1=V_{CC}$, $R_L=50\Omega$, $C_L=35pF$		3.0		0.1	20.0	ns	Figure 12
		3.00 to 3.60			6.0		1.0	40.0		
		2.30 to 2.70		2.0	10.0	35.0	2.0	45.0		
		1.65 to 1.95			22.0		2.0	70.0		
Q	Charge Injection	5.50	$C_L=1.0nF$, $V_{GEN}=0V$, $R_{GEN}=0\Omega$		15				pC	Figure 14
		3.30			11					
		2.50			8					
		1.65			6					
OIRR	Off Isolation	1.80 to 5.00	$f=1MHz$, $R_L=50\Omega$		-60				dB	Figure 13
Xtalk	Crosstalk	1.80 to 5.00	$f=1MHz$, $R_L=50\Omega$		-60				dB	Figure 13
BW	-3db Bandwidth	5.50	$R_L=50\Omega$		180				MHz	Figure 7 Figure 8 Figure 16
		3.30			180					
		2.50			180					
		1.65			180					
THD	Total Harmonic Distortion	1.80	$R_L=600\Omega$, $V_{IN}=0.5V_{PP}$, $f=20Hz$ to $20kHz$.006				%	Figure 10 Figure 17
		5.00			.002					

Capacitance

Symbol	Parameter	V_{CC} (V)	Conditions	$T_A=+25^{\circ}C$			Unit
				Min.	Typ.	Max.	
C_{IN}	Control Pin Input Capacitance	0	$f=1MHz$ See Figure 10		1.5		pF
C_{OFF}	B Port Off Capacitance	1.65 to 5.50	$f=1MHz$ See Figure 10		12		pF
C_{ON}	A Port On Capacitance	1.65 to 5.50	$f=1MHz$ See Figure 10		41		pF

Typical Performance Characteristics

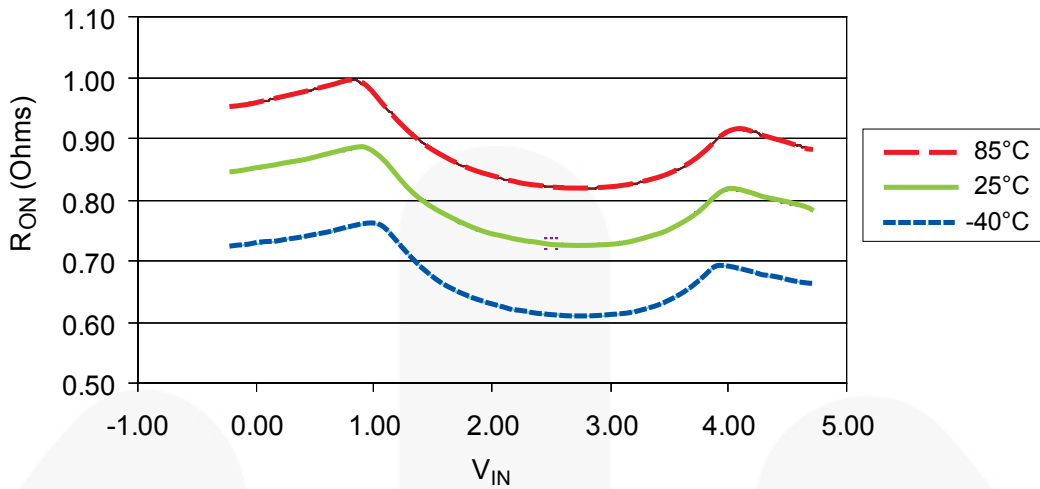

Figure 4. Switch R_{ON} (V_{CC}=4.5V)

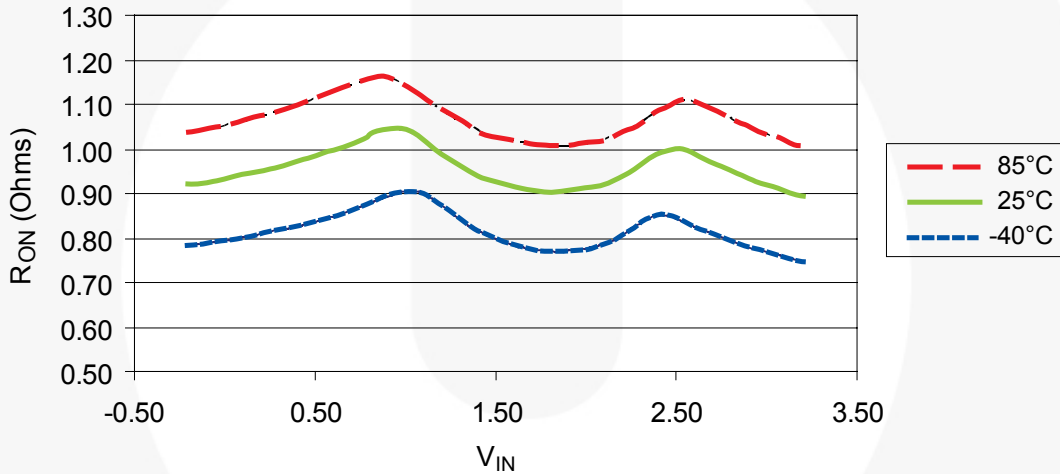

Figure 5. Switch R_{ON} (V_{CC}=3.0V)

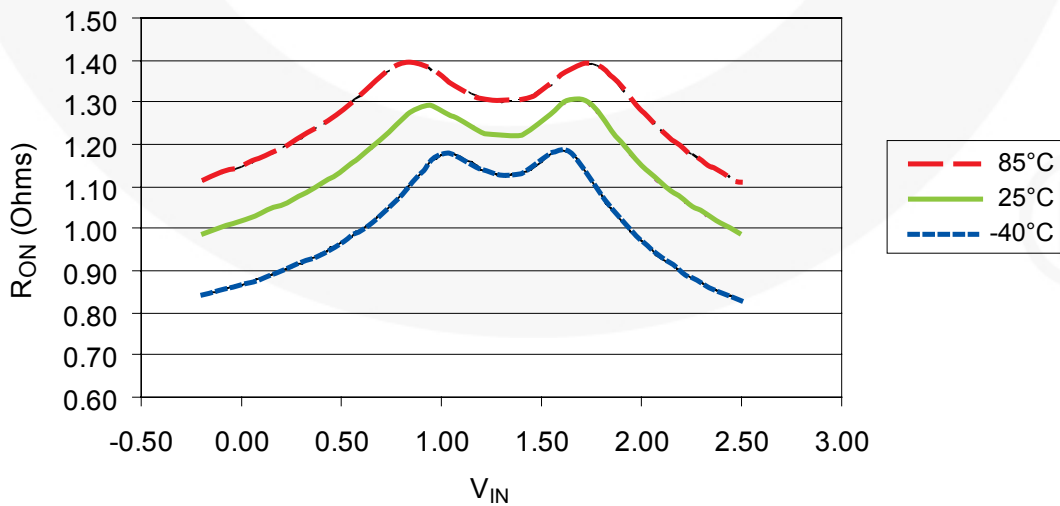

Figure 6. Switch R_{ON} (V_{CC}=2.3V)

Typical Performance Characteristics (Continued)

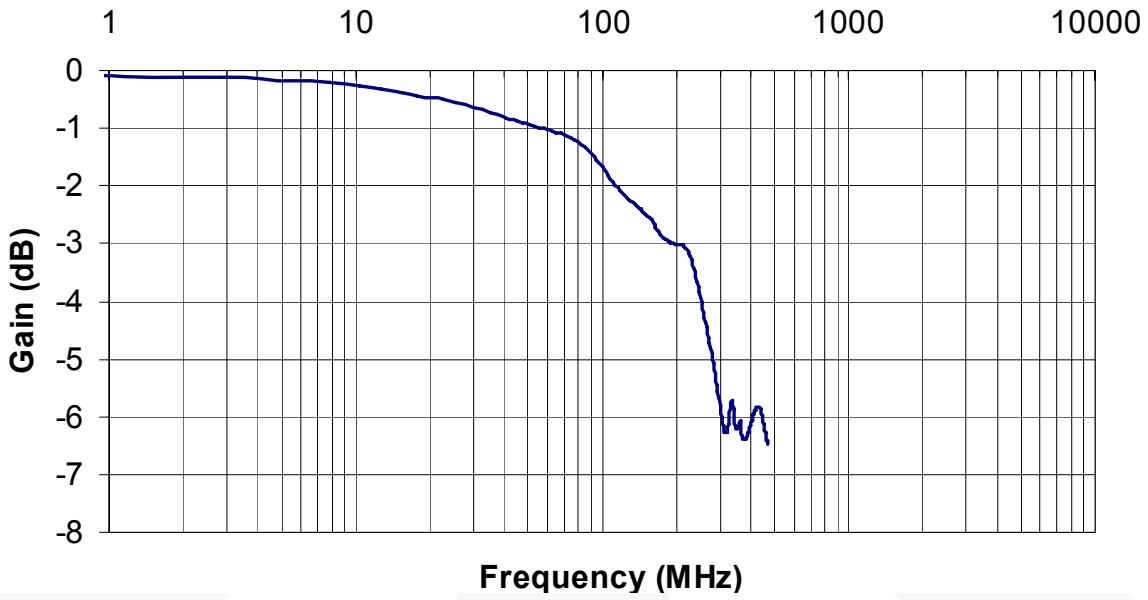

Figure 7. Frequency Response ($C_L=0pF$, $V_{CC}=5.5V$)

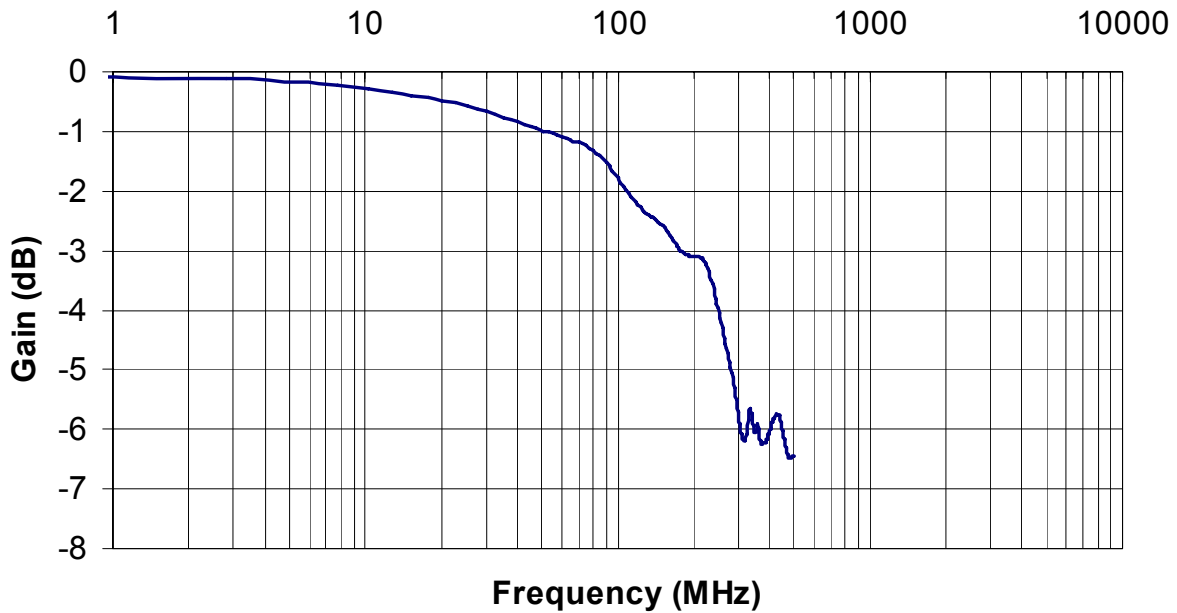

Figure 8. Frequency Response ($C_L=0pF$, $V_{CC}=3.3V$)

Typical Performance Characteristics (Continued)

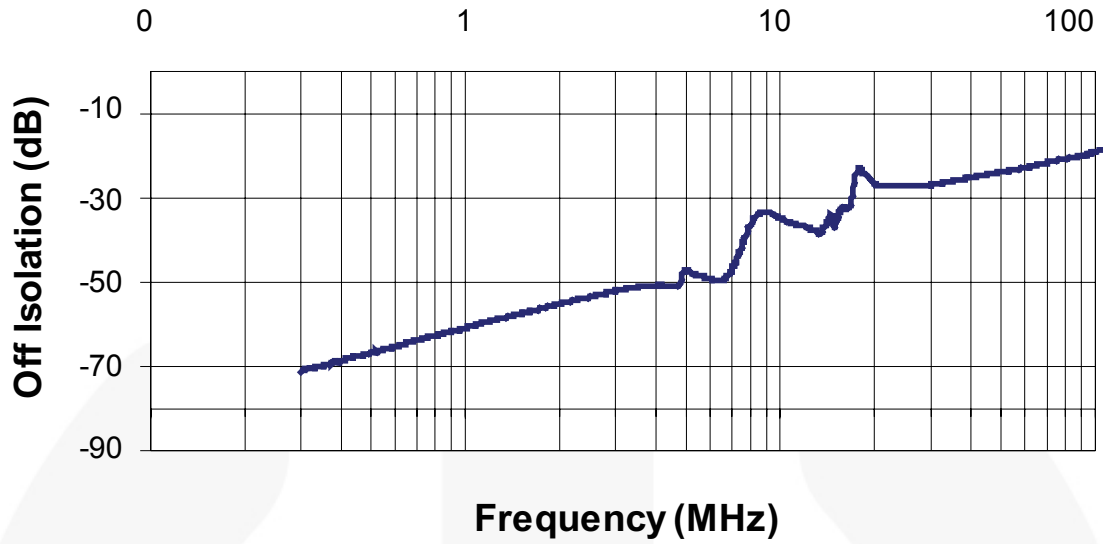

Figure 9. Off Isolation (V_{CC}=5.0V)

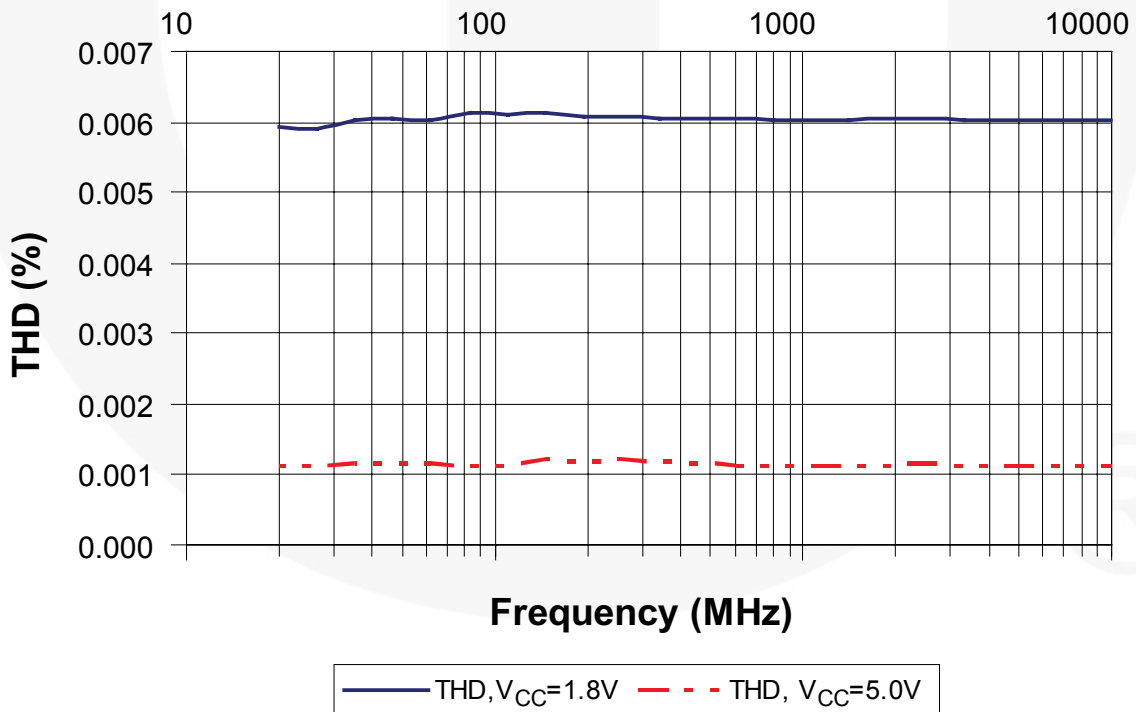
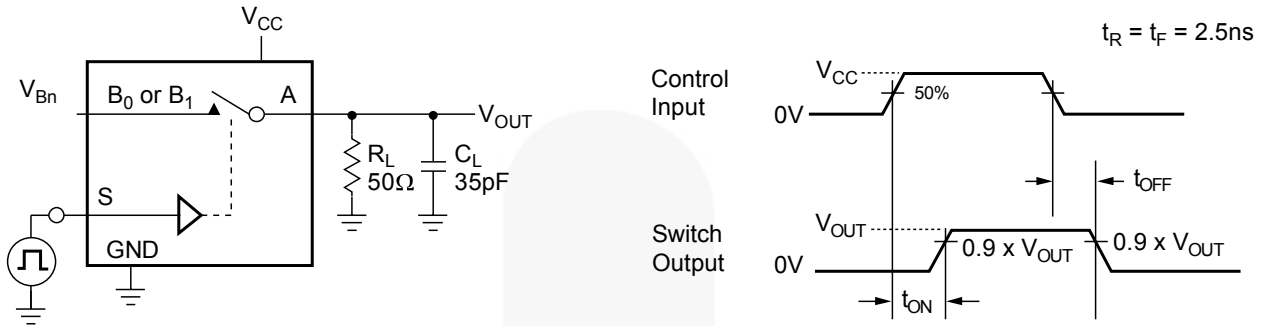

Figure 10. Total Harmonic Distortion, Frequency Response (C_L=0pF)

Test Diagrams



C_L includes fixture and stray capacitance.

Logic input waveforms inverted for switches that have the opposite logic sense.

Figure 11. Turn On / Off Timing

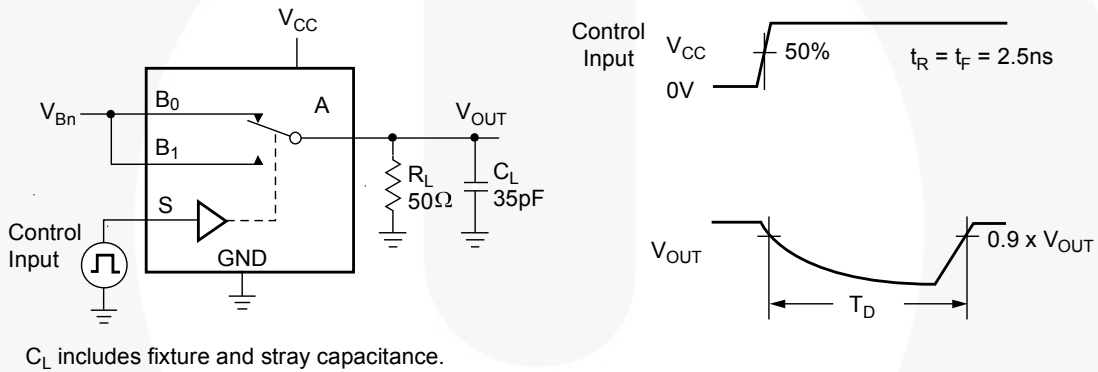

C_L includes fixture and stray capacitance.

Figure 12. Break-Before-Make Timing

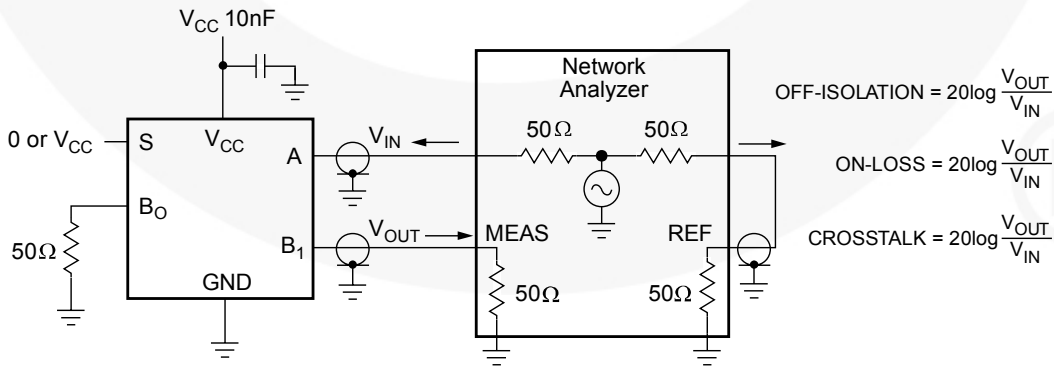

Figure 13. Off Isolation and Crosstalk

Test Diagrams (Continued)

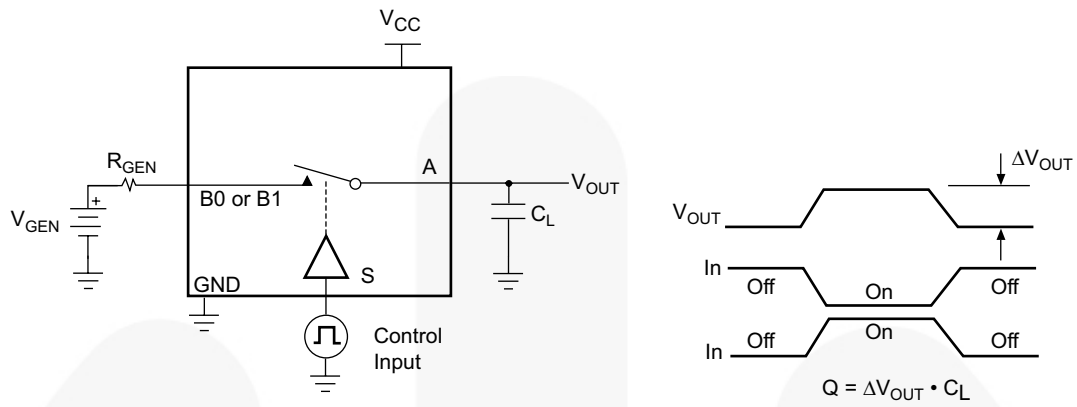

Figure 14. Charge Injection

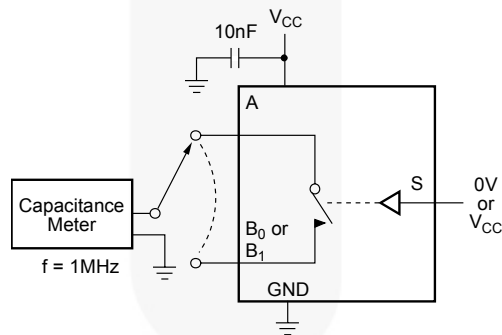

Figure 15. On / Off Capacitance Measurement Setup

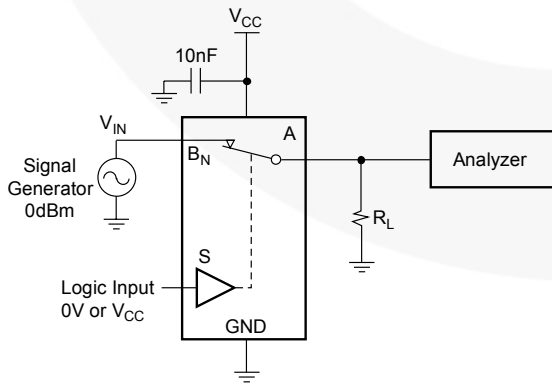

Figure 16. Bandwidth

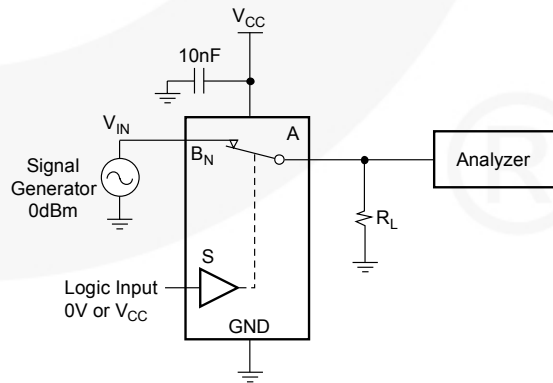
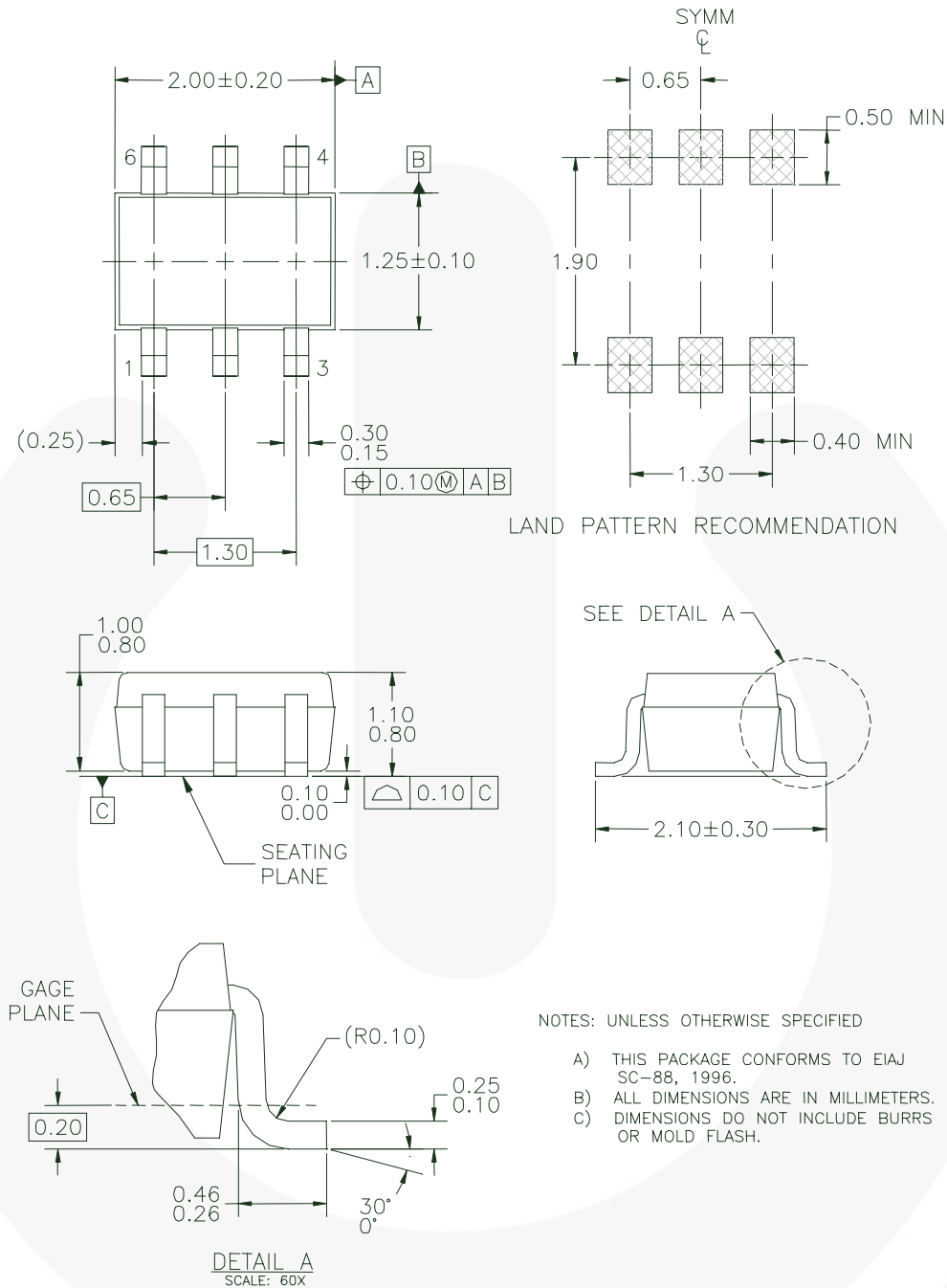

Figure 17. Harmonic Distortion

Physical Dimensions



MAA06AREV5

Figure 18. 6-Lead SC70, EIAJ SC88, 1.25mm Wide Package

[Click here for tape and reel specifications, available at:
http://www.fairchildsemi.com/products/analog/pdf/sc70-6_tr.pdf](http://www.fairchildsemi.com/products/analog/pdf/sc70-6_tr.pdf)

Package drawings are provided as a service to customers considering Fairchild components. Drawings may change in any manner without notice. Please note the revision and/or date on the drawing and contact a Fairchild Semiconductor representative to verify or obtain the most recent revision. Package specifications do not expand the terms of Fairchild's worldwide terms and conditions, specifically the warranty therein, which covers Fairchild products.

Always visit Fairchild Semiconductor's online packaging area for the most recent package drawings:
<http://www.fairchildsemi.com/packaging/>

Physical Dimensions (Continued)

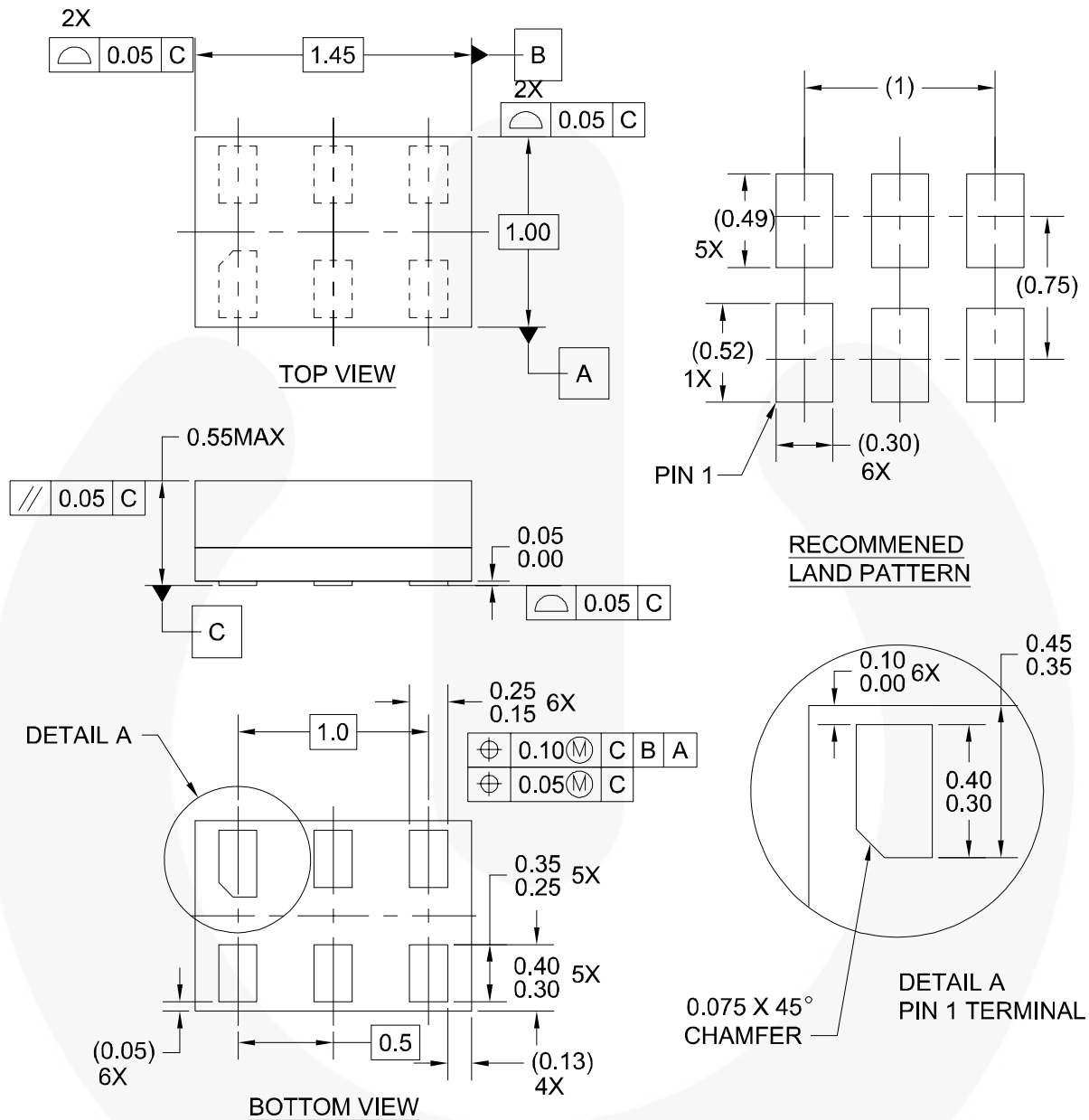

Notes:

1. CONFORMS TO JEDEC STANDARD M0-252 VARIATION UAAD
2. DIMENSIONS ARE IN MILLIMETERS
3. DRAWING CONFORMS TO ASME Y14.5M-1994

MAC06AREVC

Figure 19. 6-Lead, Micropak™ 1.0mm Wide Package





[Click here for tape and reel specifications, available at:
http://www.fairchildsemi.com/products/logic/pdf/micropak_tr.pdf](http://www.fairchildsemi.com/products/logic/pdf/micropak_tr.pdf)

Package drawings are provided as a service to customers considering Fairchild components. Drawings may change in any manner without notice. Please note the revision and/or date on the drawing and contact a Fairchild Semiconductor representative to verify or obtain the most recent revision. Package specifications do not expand the terms of Fairchild's worldwide terms and conditions, specifically the warranty therein, which covers Fairchild products.

Always visit Fairchild Semiconductor's online packaging area for the most recent package drawings:
<http://www.fairchildsemi.com/packaging/>

TRADEMARKS

The following includes registered and unregistered trademarks and service marks, owned by Fairchild Semiconductor and/or its global subsidiaries, and is not intended to be an exhaustive list of all such trademarks.

ACE ^x [®]	FPST [™]	PDP-SPM [™]	SyncFET [™]
Build it Now [™]	FRFET [®]	Power220 [®]	 SYSTEM GENERAL [®]
CorePLUS [™]	Global Power Resource SM	Power247 [®]	The Power Franchise [®]
CROSSVOLT [™]	Green FPST [™]	POWEREDGE [®]	 the Power Franchise [®]
CTL [™]	Green FPST [™] e-Series [™]	Power-SPM [™]	TinyBoost [™]
Current Transfer Logic [™]	GTO [™]	PowerTrench [®]	TinyBuck [™]
EcoSPARK [®]	<i>i-Lo</i> [™]	Programmable Active Droop [™]	TinyLogic [®]
EZSWITCH [™] *	IntelliMAX [™]	QFET [®]	TINYOPTO [™]
 [™]	ISOPLANAR [™]	QS [™]	TinyPower [™]
 [®]	MegaBuck [™]	QT Optoelectronics [™]	TinyPWM [™]
Fairchild [®]	MICROCOUPLER [™]	Quiet Series [™]	TinyWire [™]
Fairchild Semiconductor [®]	MicroFET [™]	RapidConfigure [™]	μSerDes [™]
FACT Quiet Series [™]	MicroPak [™]	SMART START [™]	UHC [®]
FACT [®]	MillerDrive [™]	SPM [®]	Ultra FRFET [™]
FAST [®]	Motion-SPM [™]	STEALTH [™]	UniFET [™]
FastvCore [™]	OPTOLOGIC [®]	SuperFET [™]	VCX [™]
FlashWriter [®] *	OPTOPLANAR [®]	SuperSOT [™] -3	
		SuperSOT [™] -6	
		SuperSOT [™] -8	

* EZSWITCH[™] and FlashWriter[®] are trademarks of System General Corporation, used under license by Fairchild Semiconductor.

DISCLAIMER

FAIRCHILD SEMICONDUCTOR RESERVES THE RIGHT TO MAKE CHANGES WITHOUT FURTHER NOTICE TO ANY PRODUCTS HEREIN TO IMPROVE RELIABILITY, FUNCTION, OR DESIGN. FAIRCHILD DOES NOT ASSUME ANY LIABILITY ARISING OUT OF THE APPLICATION OR USE OF ANY PRODUCT OR CIRCUIT DESCRIBED HEREIN; NEITHER DOES IT CONVEY ANY LICENSE UNDER ITS PATENT RIGHTS, NOR THE RIGHTS OF OTHERS. THESE SPECIFICATIONS DO NOT EXPAND THE TERMS OF FAIRCHILD'S WORLDWIDE TERMS AND CONDITIONS, SPECIFICALLY THE WARRANTY THEREIN, WHICH COVERS THESE PRODUCTS.

LIFE SUPPORT POLICY

FAIRCHILD'S PRODUCTS ARE NOT AUTHORIZED FOR USE AS CRITICAL COMPONENTS IN LIFE SUPPORT DEVICES OR SYSTEMS WITHOUT THE EXPRESS WRITTEN APPROVAL OF FAIRCHILD SEMICONDUCTOR CORPORATION.

As used herein:

- Life support devices or systems are devices or systems which, (a) are intended for surgical implant into the body or (b) support or sustain life, and (c) whose failure to perform when properly used in accordance with instructions for use provided in the labeling, can be reasonably expected to result in a significant injury of the user.
- A critical component in any component of a life support device, or system whose failure to perform can be reasonably expected to cause the failure of the life support device or system, or to affect its safety or effectiveness.

PRODUCT STATUS DEFINITIONS

Definition of Terms

Datasheet Identification	Product Status	Definition
Advance Information	Formative or In Design	This datasheet contains the design specifications for product development. Specifications may change in any manner without notice.
Preliminary	First Production	This datasheet contains preliminary data; supplementary data will be published at a later date. Fairchild Semiconductor reserves the right to make changes at any time without notice to improve design.
No Identification Needed	Full Production	This datasheet contains final specifications. Fairchild Semiconductor reserves the right to make changes at any time without notice to improve the design.
Obsolete	Not In Production	This datasheet contains specifications on a product that has been discontinued by Fairchild Semiconductor. The datasheet is printed for reference information only.

Rev. I32