



# FAN3226 / FAN3227 / FAN3228 / FAN3229

## Dual 2A High-Speed, Low-Side Gate Drivers

### Features

- Industry-Standard Pinouts
- 4.5 to 18V Operating Range
- 3A Peak Sink/Source at  $V_{DD} = 12V$
- 2.4A Sink / 1.6A Source at  $V_{OUT} = 6V$
- Choice of TTL or CMOS Input Thresholds
- Four Versions of Dual Independent Drivers:
  - Dual Inverting + Enable (FAN3226)
  - Dual Non-Inverting + Enable (FAN3227)
  - Dual Inputs in Two Pin Configurations:
    - Standard (FAN3228)
    - Alternate (FAN3229) for compatibility with TI
- Internal Resistors Turn Driver Off If No Inputs
- MillerDrive™ Technology
- 12ns / 9ns Typical Rise/Fall Times with 1nF Load
- Typical Propagation Delay Under 20ns Matched within 1ns to the Other Channel
- Double Current Capability by Paralleling Channels
- 8-Lead 3x3mm MLP or 8-Lead SOIC Package
- Rated from  $-40^{\circ}C$  to  $+125^{\circ}C$  Ambient

### Applications

- Switch-Mode Power Supplies
- High-Efficiency MOSFET Switching
- Synchronous Rectifier Circuits
- DC-to-DC Converters
- Motor Control

### Description

The FAN3226-29 family of dual 2A gate drivers is designed to drive N-channel enhancement-mode MOSFETs in low-side switching applications by providing high peak current pulses during the short switching intervals. The driver is available with either TTL or CMOS input thresholds. Internal circuitry provides an under-voltage lockout function by holding the output low until the supply voltage is within the operating range. In addition, the drivers feature matched internal propagation delays between A and B channels for applications requiring dual gate drives with critical timing, such as synchronous rectifiers. This enables connecting two drivers in parallel to effectively double the current capability driving a single MOSFET.

The FAN322X drivers incorporate MillerDrive™ architecture for the final output stage. This bipolar-MOSFET combination provides high current during the Miller plateau stage of the MOSFET turn-on / turn-off process to minimize switching loss, while providing rail-to-rail voltage swing and reverse current capability.

The FAN3226 offers two inverting drivers and the FAN3227 offers two non-inverting drivers. Each device has dual independent enable pins that default to ON if not connected. In the FAN3228 and FAN3229, each channel has dual inputs of opposite polarity, which allows configuration as non-inverting or inverting with an optional enable function using the second input. If one or both inputs are left unconnected, internal resistors bias the inputs such that the output is pulled low to hold the power MOSFET off.

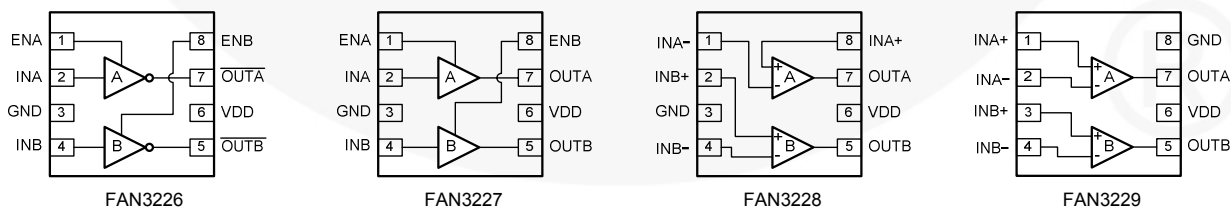



Figure 1. Pin Configurations

## Ordering Information

Part Number	Logic	Input Threshold	Package	Packing Method	Quantity per Reel
FAN3226CMPX	Dual Inverting Channels + Dual Enable	CMOS	3x3mm MLP-8	Tape & Reel	3,000
FAN3226CMX			SOIC-8	Tape & Reel	2,500
FAN3226TMPX		TTL	3x3mm MLP-8	Tape & Reel	3,000
FAN3226TMX			SOIC-8	Tape & Reel	2,500
FAN3227CMPX	Dual Non-Inverting Channels + Dual Enable	CMOS	3x3mm MLP-8	Tape & Reel	3,000
FAN3227CMX			SOIC-8	Tape & Reel	2,500
FAN3227TMPX		TTL	3x3mm MLP-8	Tape & Reel	3,000
FAN3227TMX			SOIC-8	Tape & Reel	2,500
FAN3228CMPX	Dual Channels of Two-Input / One-Output Drivers, Pin Configuration 1	CMOS	3x3mm MLP-8	Tape & Reel	3,000
FAN3228CMX			SOIC-8	Tape & Reel	2,500
FAN3228TMPX		TTL	3x3mm MLP-8	Tape & Reel	3,000
FAN3228TMX			SOIC-8	Tape & Reel	2,500
FAN3229CMPX	Dual Channels of Two-Input / One-Output Drivers, Pin Configuration 2	CMOS	3x3mm MLP-8	Tape & Reel	3,000
FAN3229CMX			SOIC-8	Tape & Reel	2,500
FAN3229TMPX		TTL	3x3mm MLP-8	Tape & Reel	3,000
FAN3229TMX			SOIC-8	Tape & Reel	2,500

 All packages are lead free per JEDEC: J-STD-020B standard.

## Package Outlines

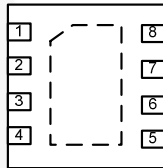

Figure 2. 3x3mm MLP-8 (Top View)

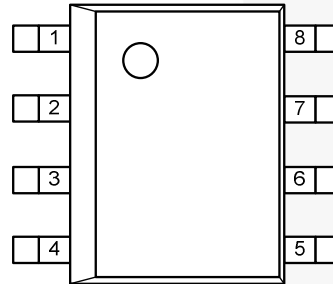

Figure 3. SOIC-8 (Top View)

## Thermal Characteristics<sup>(1)</sup>

Package	$\Theta_{JL}$ <sup>(2)</sup>	$\Theta_{JT}$ <sup>(3)</sup>	$\Theta_{JA}$ <sup>(4)</sup>	$\Psi_{JB}$ <sup>(5)</sup>	$\Psi_{JT}$ <sup>(6)</sup>	Units
8-Lead 3x3mm Molded Leadless Package (MLP)	1.6	68	43	3.5	0.8	°C/W
8-Pin Small Outline Integrated Circuit (SOIC)	40	31	89	43	3.0	°C/W

### Notes:

- Estimates derived from thermal simulation; actual values depend on the application.
- $\Theta_{JL}$  ( $\Theta_{JL}$ ): Thermal resistance between the semiconductor junction and the bottom surface of all the leads (including any thermal pad) that are typically soldered to a PCB.
- $\Theta_{JT}$  ( $\Theta_{JT}$ ): Thermal resistance between the semiconductor junction and the top surface of the package, assuming it is held at a uniform temperature by a top-side heatsink.
- $\Theta_{JA}$  ( $\Theta_{JA}$ ): Thermal resistance between junction and ambient, dependent on the PCB design, heat sinking, and airflow. The value given is for natural convection with no heatsink, as specified in JEDEC standards JESD51-2, JESD51-5, and JESD51-7, as appropriate.
- $\Psi_{JB}$  ( $\Psi_{JB}$ ): Thermal characterization parameter providing correlation between semiconductor junction temperature and an application circuit board reference point for the thermal environment defined in Note 4. For the MLP-8 package, the board reference is defined as the PCB copper connected to the thermal pad and protruding from either end of the package. For the SOIC-8 package, the board reference is defined as the PCB copper adjacent to pin 6.
- $\Psi_{JT}$  ( $\Psi_{JT}$ ): Thermal characterization parameter providing correlation between the semiconductor junction temperature and the center of the top of the package for the thermal environment defined in Note 4.

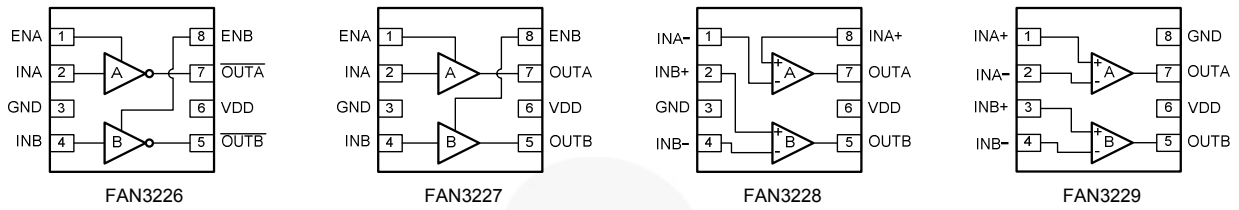

**Figure 4. Pin Configurations (Repeated)**

**Pin Definitions**

Name	Pin Description
ENA	<b>Enable Input for Channel A.</b> Pull pin low to inhibit driver A. ENA has TTL thresholds for both TTL and CMOS IN <sub>x</sub> threshold.
ENB	<b>Enable Input for Channel B.</b> Pull pin low to inhibit driver B. ENB has TTL thresholds for both TTL and CMOS IN <sub>x</sub> threshold.
GND	<b>Ground.</b> Common ground reference for input and output circuits.
INA	<b>Input to Channel A.</b>
INA+	<b>Non-Inverting Input to Channel A.</b> Connect to V <sub>DD</sub> to enable output.
INA-	<b>Inverting Input to Channel A.</b> Connect to GND to enable output.
INB	<b>Input to Channel B.</b>
INB+	<b>Non-Inverting Input to Channel B.</b> Connect to V <sub>DD</sub> to enable output.
INB-	<b>Inverting Input to Channel B.</b> Connect to GND to enable output.
OUTA	<b>Gate Drive Output A:</b> Held low unless required input(s) are present and V <sub>DD</sub> is above UVLO threshold.
OUTB	<b>Gate Drive Output B:</b> Held low unless required input(s) are present and V <sub>DD</sub> is above UVLO threshold.
$\overline{\text{OUTA}}$	<b>Gate Drive Output A</b> (inverted from the input): Held low unless required input is present and V <sub>DD</sub> is above UVLO threshold.
$\overline{\text{OUTB}}$	<b>Gate Drive Output B</b> (inverted from the input): Held low unless required input is present and V <sub>DD</sub> is above UVLO threshold.
P1	<b>Thermal Pad (MLP only).</b> Exposed metal on the bottom of the package; may be left floating or connected to GND; NOT suitable for carrying current.
VDD	<b>Supply Voltage.</b> Provides power to the IC.

**Output Logic**

FAN3226 (x=A or B)		
EN <sub>x</sub>	IN <sub>x</sub>	$\overline{\text{OUT}}_x$
0	0	0
0	1 <sup>(7)</sup>	0
1 <sup>(7)</sup>	0	1
1 <sup>(7)</sup>	1 <sup>(7)</sup>	0

FAN3227 (x=A or B)		
EN <sub>x</sub>	IN <sub>x</sub>	OUT <sub>x</sub>
0	0 <sup>(7)</sup>	0
0	1	0
1 <sup>(7)</sup>	0 <sup>(7)</sup>	0
1 <sup>(7)</sup>	1	1

FAN3228 and FAN3229 (x=A or B)		
IN <sub>x</sub> +	IN <sub>x</sub> -	OUT <sub>x</sub>
0 <sup>(7)</sup>	0	0
0 <sup>(7)</sup>	1 <sup>(7)</sup>	0
1	0	1
1	1 <sup>(7)</sup>	0

**Note:**

7. Default input signal if no external connection is made.

Block Diagrams

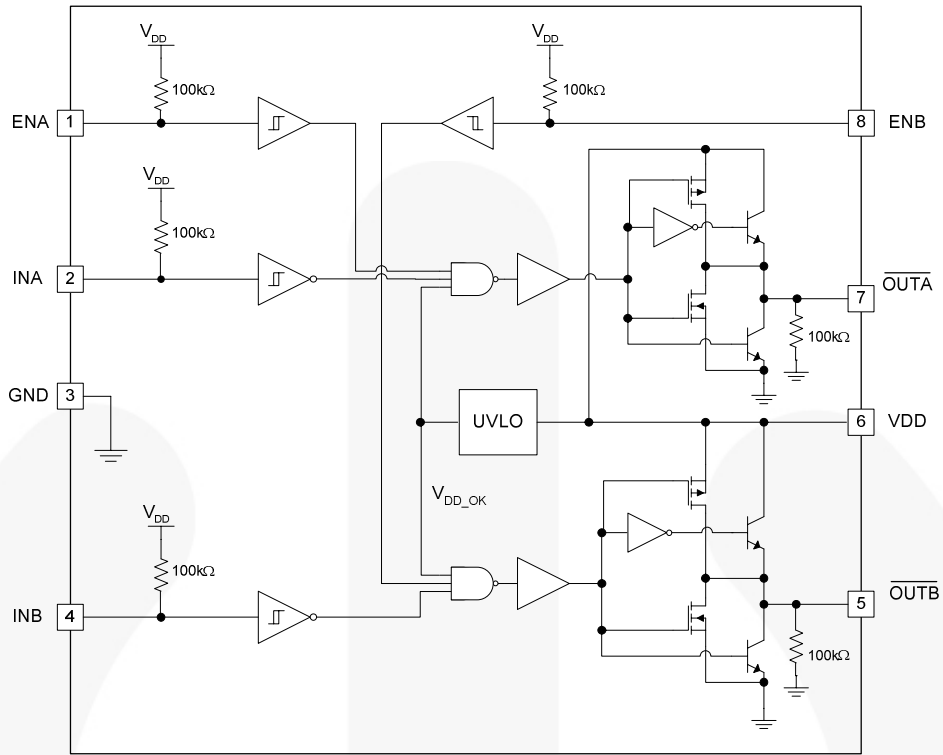

Figure 5. FAN3226 Block Diagram

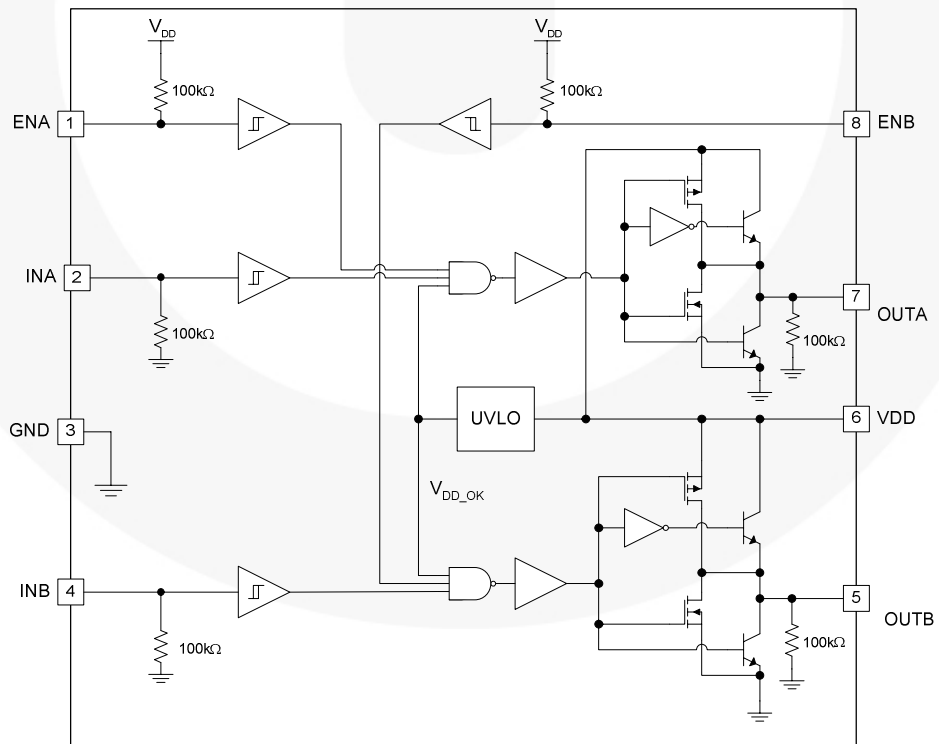

Figure 6. FAN3227 Block Diagram

Block Diagrams

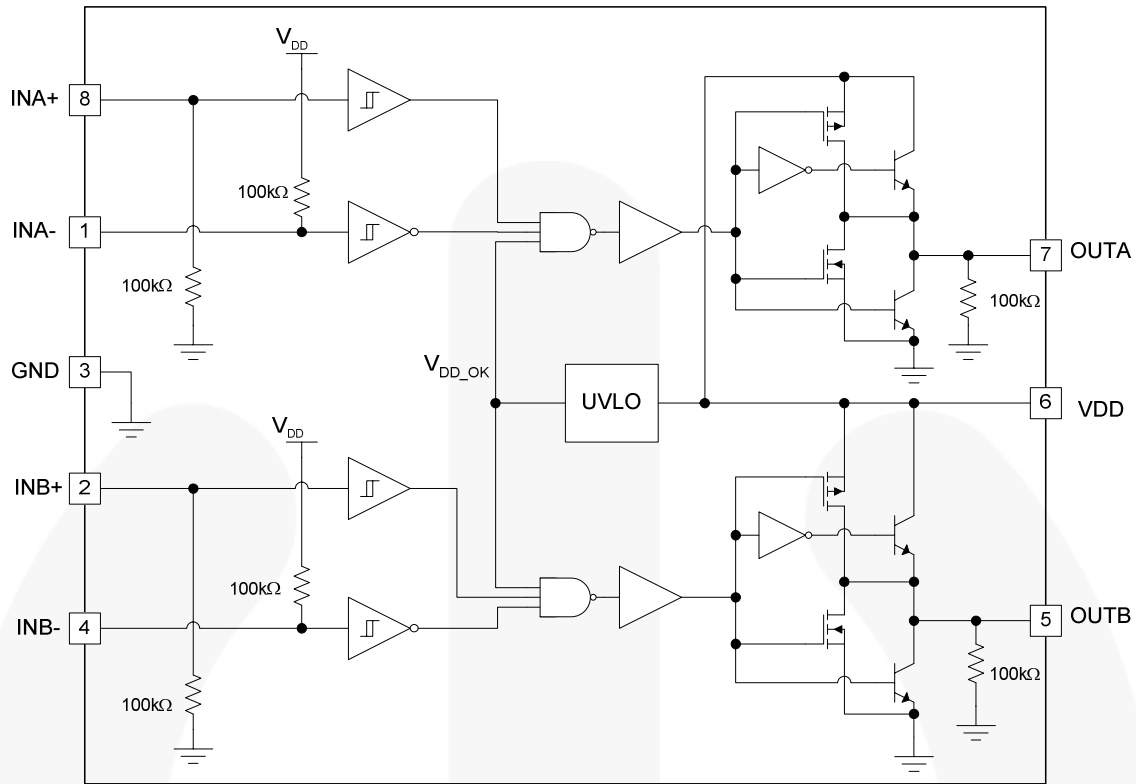

Figure 7. FAN3228 Block Diagram

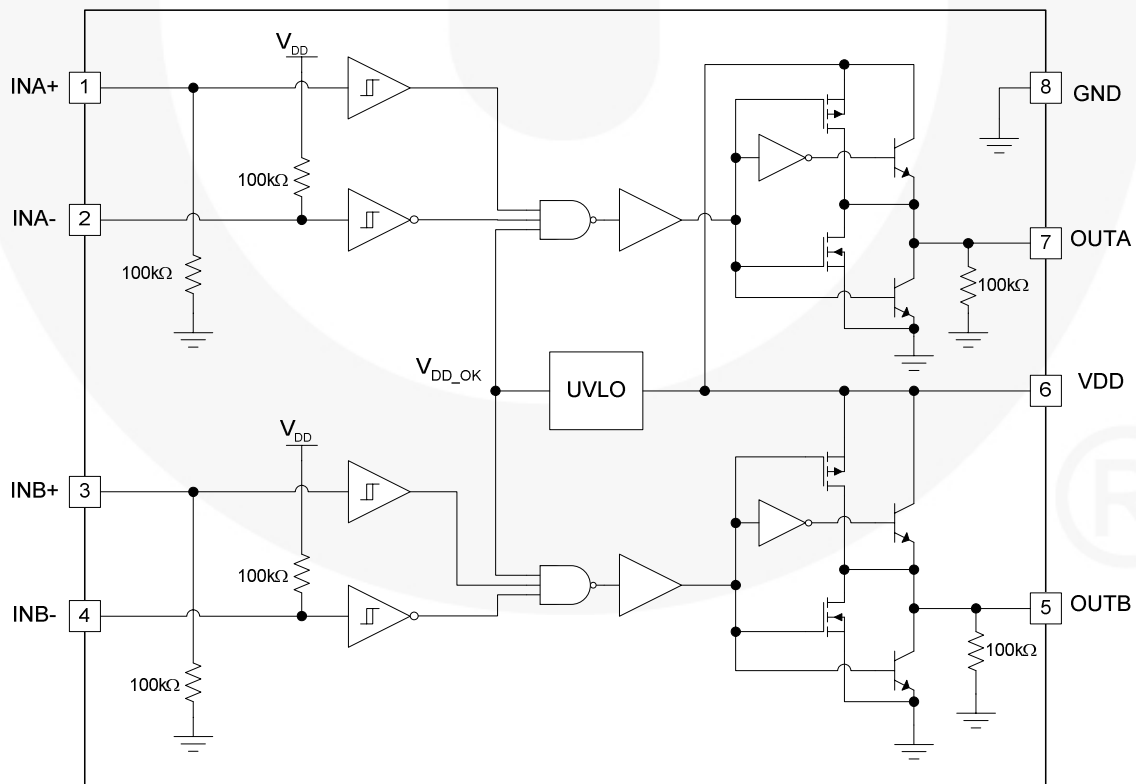

Figure 8. FAN3229 Block Diagram

## Absolute Maximum Ratings

Stresses exceeding the absolute maximum ratings may damage the device. The device may not function or be operable above the recommended operating conditions and stressing the parts to these levels is not recommended. In addition, extended exposure to stresses above the recommended operating conditions may affect device reliability. The absolute maximum ratings are stress ratings only.

Symbol	Parameter		Min.	Max.	Unit
V <sub>DD</sub>	VDD to PGND		-0.3	20.0	V
V <sub>EN</sub>	ENA and ENB to GND		GND - 0.3	V <sub>DD</sub> + 0.3	V
V <sub>IN</sub>	INA, INA+, INA-, INB, INB+ and INB- to GND		GND - 0.3	V <sub>DD</sub> + 0.3	V
V <sub>OUT</sub>	OUTA and OUTB to GND		GND - 0.3	V <sub>DD</sub> + 0.3	V
T <sub>L</sub>	Lead Soldering Temperature (10 Seconds)			+260	°C
T <sub>J</sub>	Junction Temperature			+150	°C
T <sub>STG</sub>	Storage Temperature		-65	+150	°C
ESD	Electrostatic Discharge Protection Level	Human Body Model, JEDEC JESD22-A114	4		kV
		Charged Device Model, JEDEC JESD22-C101	1		kV

## Recommended Operating Conditions

The Recommended Operating Conditions table defines the conditions for actual device operation. Recommended operating conditions are specified to ensure optimal performance to the datasheet specifications. Fairchild does not recommend exceeding them or designing to Absolute Maximum Ratings.

Symbol	Parameter		Min.	Max.	Unit
V <sub>DD</sub>	Supply Voltage Range		4.5	18.0	V
V <sub>EN</sub>	Enable Voltage ENA and ENB		0	V <sub>DD</sub>	V
V <sub>IN</sub>	Input Voltage INA, INA+, INA-, INB, INB+ and INB-		0	V <sub>DD</sub>	V
T <sub>A</sub>	Operating Ambient Temperature		-40	+125	°C

## Electrical Characteristics

Unless otherwise noted,  $V_{DD}=12V$ ,  $T_J=-40^{\circ}C$  to  $+125^{\circ}C$ . Currents are defined as positive into the device and negative out of the device.

Symbol	Parameter	Conditions	Min.	Typ.	Max.	Unit
<b>Supply</b>						
$V_{DD}$	Operating Range		4.5		18.0	V
$I_{DD}$	Supply Current Inputs / EN Not Connected	TTL		0.67	0.95	mA
		CMOS <sup>(8)</sup>		0.56	0.80	mA
$V_{ON}$	Turn-On Voltage	INA=ENA= $V_{DD}$ , INB=ENB=0V	3.5	3.9	4.3	V
$V_{OFF}$	Turn-Off Voltage	INA=ENA= $V_{DD}$ , INB=ENB=0V	3.3	3.7	4.1	V
<b>Inputs (FAN322xT)<sup>(9)</sup></b>						
$V_{IL\_T}$	INx Logic Low Threshold		0.8	1.2		V
$V_{IH\_T}$	INx Logic High Threshold			1.6	2.0	V
$I_{IN+}$	Non-inverting Input	IN from 0 to $V_{DD}$	-1.5		175.0	$\mu A$
$I_{IN-}$	Inverting Input	IN from 0 to $V_{DD}$	-175.0		1.5	$\mu A$
$V_{HYS\_T}$	TTL Logic Hysteresis Voltage		0.2	0.4	0.8	V
<b>Inputs (FAN322xC)<sup>(9)</sup></b>						
$V_{IL\_C}$	INx Logic Low Threshold		30	38		% $V_{DD}$
$V_{IH\_C}$	INx Logic High Threshold			55	70	% $V_{DD}$
$I_{INL}$	IN Current, Low	IN from 0 to $V_{DD}$	-1		175	$\mu A$
$I_{INH}$	IN Current, High	IN from 0 to $V_{DD}$	-175		1	$\mu A$
$V_{HYS\_C}$	CMOS Logic Hysteresis Voltage			17		% $V_{DD}$
<b>ENABLE (FAN3226C, FAN3226T, FAN3227C, FAN3227T)</b>						
$V_{ENL}$	Enable Logic Low Threshold	EN from 5V to 0V	0.8	1.2		V
$V_{ENH}$	Enable Logic High Threshold	EN from 0V to 5V		1.6	2.0	V
$V_{HYS\_T}$	TTL Logic Hysteresis Voltage <sup>(10)</sup>			0.4		V
$R_{PU}$	Enable Pull-up Resistance <sup>(10)</sup>			100		k $\Omega$
$t_{D1}, t_{D2}$	Propagation Delay, EN Rising <sup>(11)</sup>	0 - 5V <sub>IN</sub> , 1V/ns Slew Rate	7	14	21	ns
$t_{D1}, t_{D2}$	Propagation Delay, EN Falling <sup>(11)</sup>	0 - 5V <sub>IN</sub> , 1V/ns Slew Rate	10	19	30	ns

Continued on the following page...

### Electrical Characteristics (Continued)

Unless otherwise noted,  $V_{DD}=12V$ ,  $T_J=-40^{\circ}C$  to  $+125^{\circ}C$ . Currents are defined as positive into the device and negative out of the device.

Symbol	Parameter	Conditions	Min.	Typ.	Max.	Unit
<b>Output</b>						
$I_{SINK}$	OUT Current, Mid-Voltage, Sinking <sup>(10)</sup>	OUT at $V_{DD}/2$ , $C_{LOAD}=0.1\mu F$ , $f=1kHz$		2.4		A
$I_{SOURCE}$	OUT Current, Mid-Voltage, Sourcing <sup>(10)</sup>	OUT at $V_{DD}/2$ , $C_{LOAD}=0.1\mu F$ , $f=1kHz$		-1.6		A
$I_{PK\_SINK}$	OUT Current, Peak, Sinking <sup>(10)</sup>	$C_{LOAD}=0.1\mu F$ , $f=1kHz$		3		A
$I_{PK\_SOURCE}$	OUT Current, Peak, Sourcing <sup>(10)</sup>	$C_{LOAD}=0.1\mu F$ , $f=1kHz$		-3		A
$t_{RISE}$	Output Rise Time <sup>(11)</sup>	$C_{LOAD}=1000pF$		12	20	ns
$t_{FALL}$	Output Fall Time <sup>(11)</sup>	$C_{LOAD}=1000pF$		9	15	ns
$t_{D1}, t_{D2}$	Output Propagation Delay, CMOS Inputs <sup>(11)</sup>	0 - $12V_{IN}$ , 1V/ns Slew Rate	6	15	29	ns
$t_{D1}, t_{D2}$	Output Propagation Delay, TTL Inputs <sup>(11)</sup>	0 - $5V_{IN}$ , 1V/ns Slew Rate	7	16	30	ns
	Propagation Matching Between Channels	$INA=INB$ , $OUTA$ and $OUTB$ at 50% point		1	2	ns
$I_{RVS}$	Output Reverse Current Withstand <sup>(10)</sup>			500		mA

**Notes:**

- 8. Lower supply current due to inactive TTL circuitry.
- 9. EN inputs have TTL thresholds; refer to the ENABLE section.
- 10. Not tested in production.
- 11. See Timing Diagrams of Figure 9 and Figure 10.

### Timing Diagrams

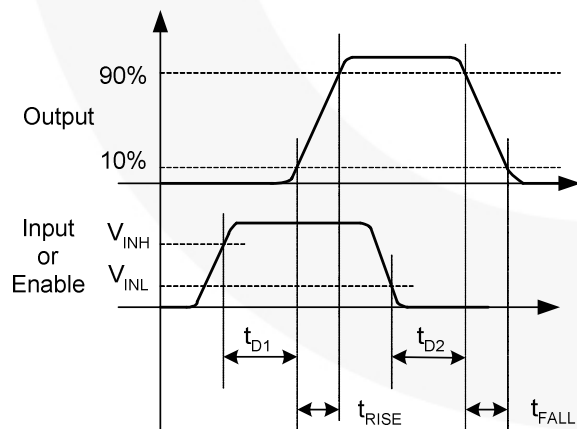

**Figure 9. Non-inverting**

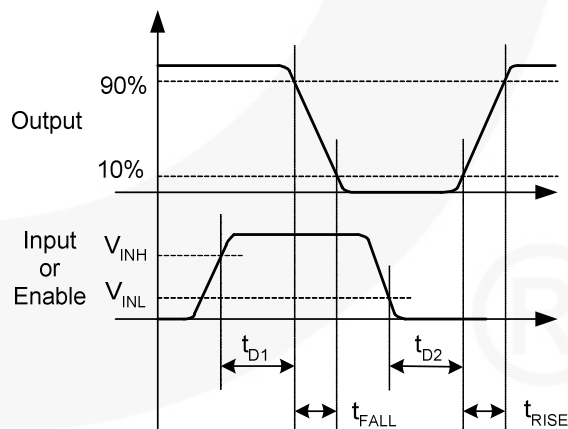

**Figure 10. Inverting**



## Typical Performance Characteristics

Typical characteristics are provided at 25°C and  $V_{DD}=12V$  unless otherwise noted.

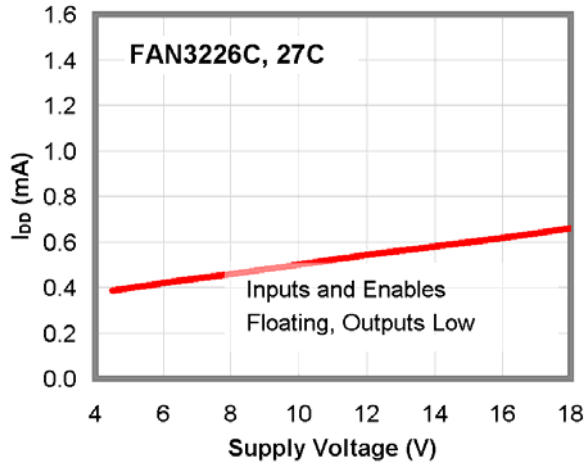

Figure 11.  $I_{DD}$  (Static) vs. Supply Voltage<sup>(12)</sup>

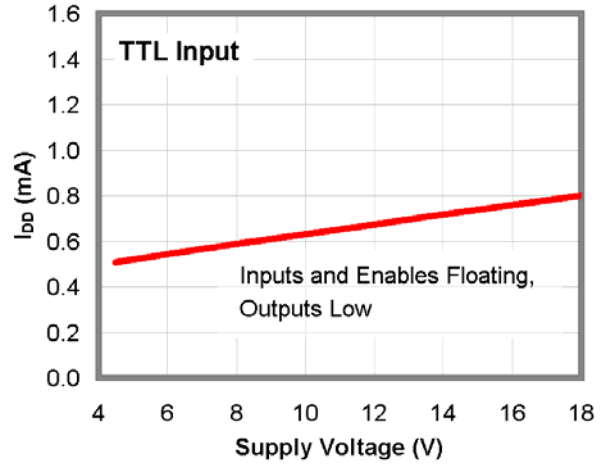

Figure 12.  $I_{DD}$  (Static) vs. Supply Voltage<sup>(12)</sup>

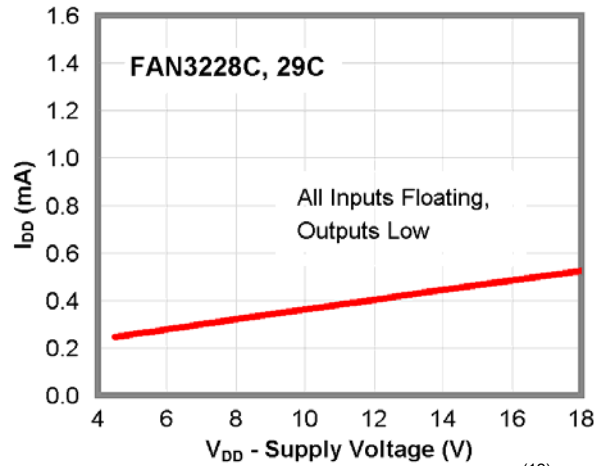

Figure 13.  $I_{DD}$  (Static) vs. Supply Voltage<sup>(12)</sup>

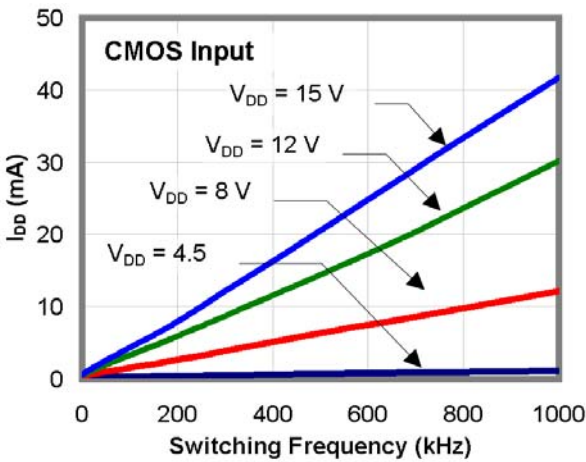

Figure 14.  $I_{DD}$  (No-Load) vs. Frequency

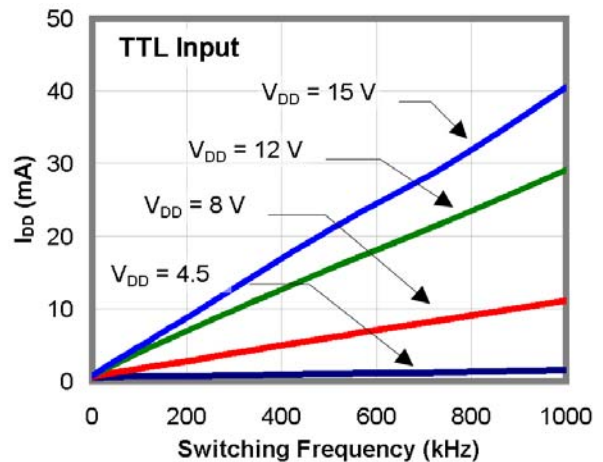

Figure 15.  $I_{DD}$  (No-Load) vs. Frequency

## Typical Performance Characteristics

Typical characteristics are provided at 25°C and  $V_{DD}=12V$  unless otherwise noted.

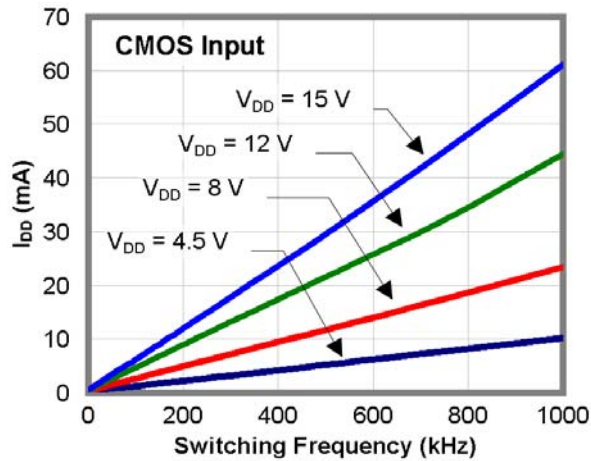

Figure 16.  $I_{DD}$  (1nF Load) vs. Frequency

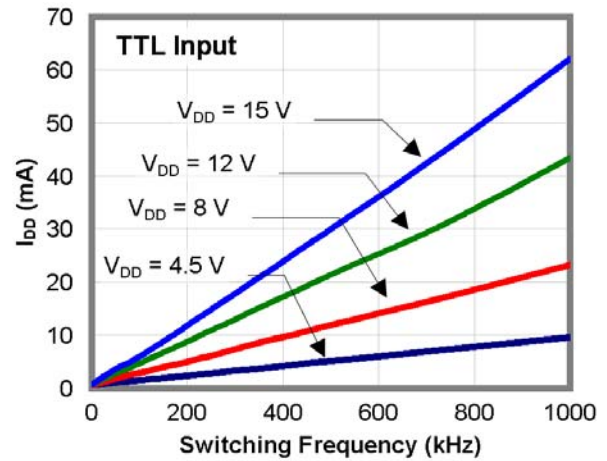

Figure 17.  $I_{DD}$  (1nF Load) vs. Frequency

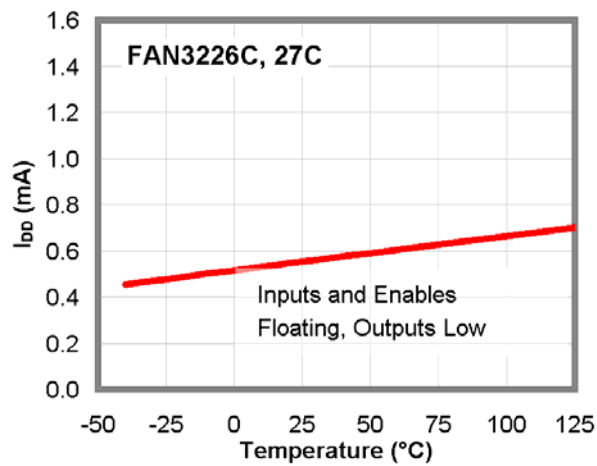

Figure 18.  $I_{DD}$  (Static) vs. Temperature<sup>(12)</sup>

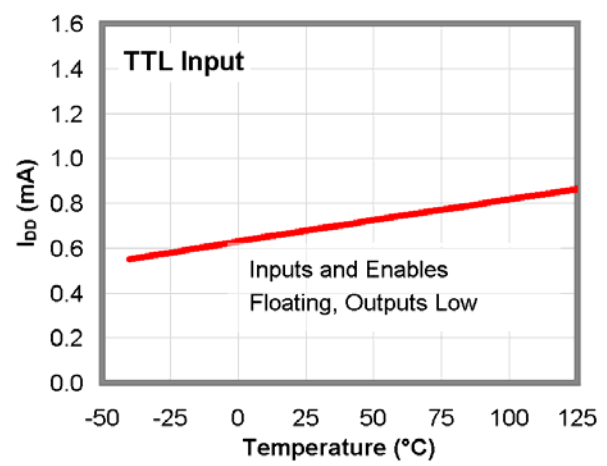

Figure 19.  $I_{DD}$  (Static) vs. Temperature<sup>(12)</sup>

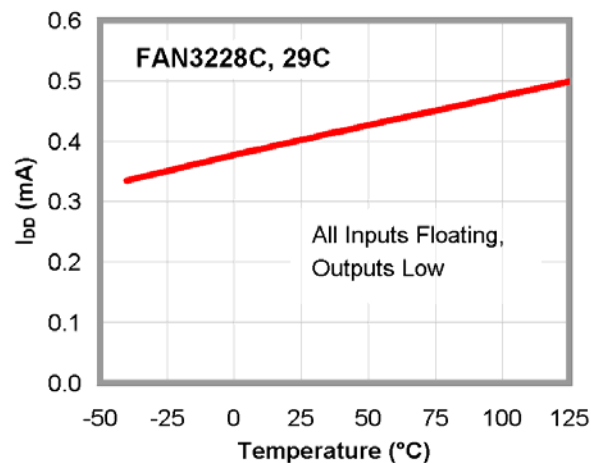

Figure 20.  $I_{DD}$  (Static) vs. Temperature<sup>(12)</sup>

## Typical Performance Characteristics

Typical characteristics are provided at 25°C and  $V_{DD}=12V$  unless otherwise noted.

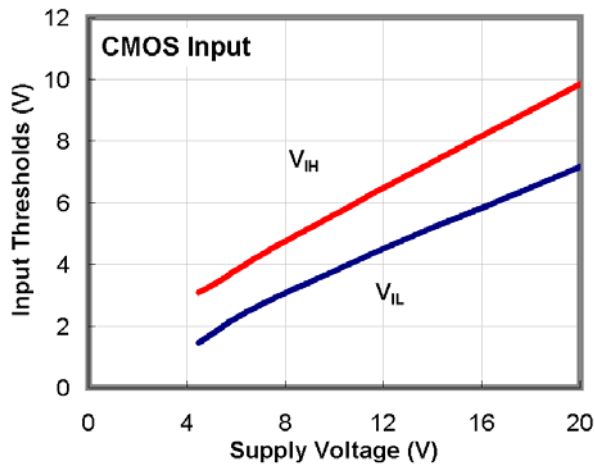

Figure 21. Input Thresholds vs. Supply Voltage

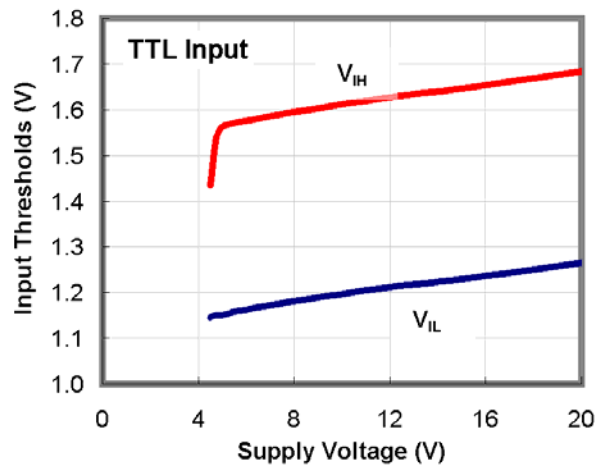

Figure 22. Input Thresholds vs. Supply Voltage

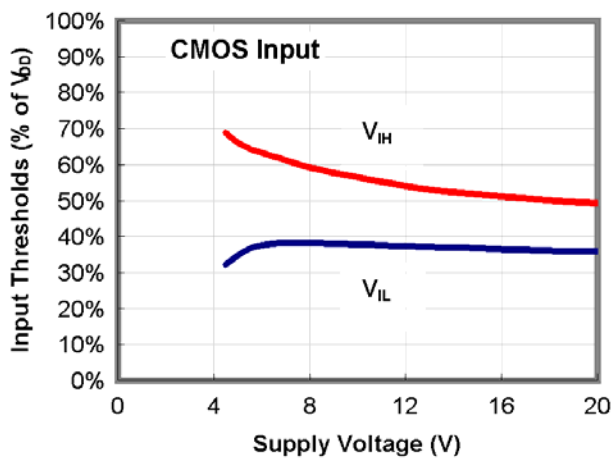

Figure 23. Input Threshold % vs. Supply Voltage

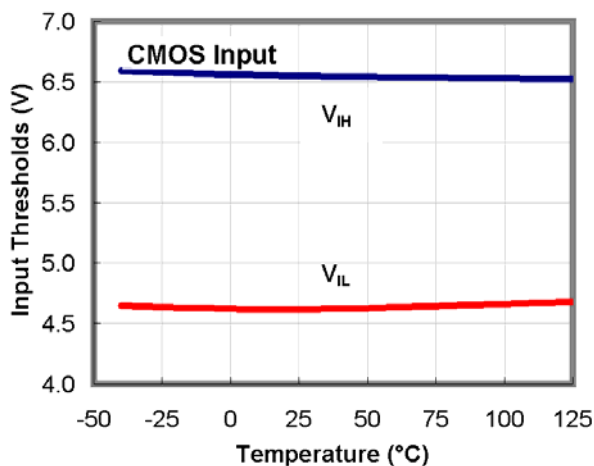

Figure 24. Input Thresholds vs. Temperature

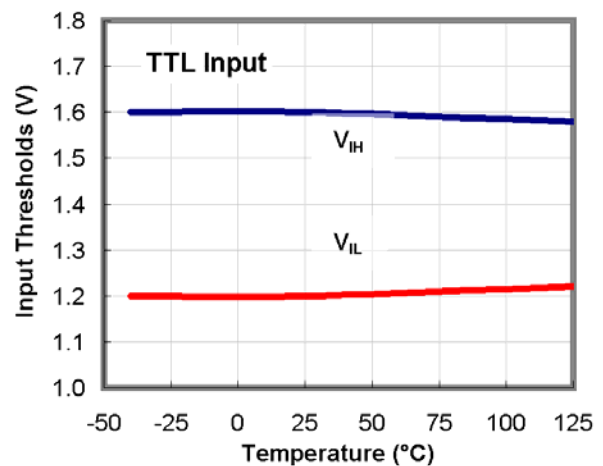

Figure 25. Input Thresholds vs. Temperature

## Typical Performance Characteristics

Typical characteristics are provided at 25°C and  $V_{DD}=12V$  unless otherwise noted.

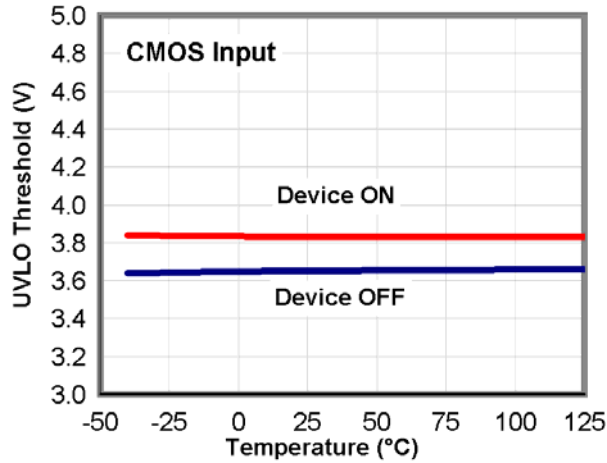

Figure 26. UVLO Thresholds vs. Temperature

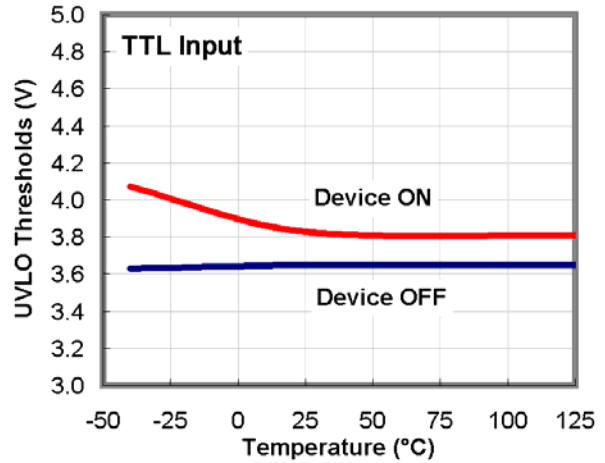

Figure 27. UVLO Threshold vs. Temperature

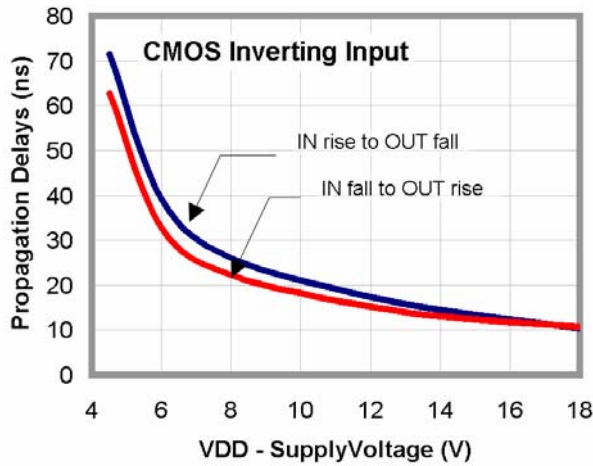

Figure 28. Propagation Delays vs. Supply Voltage

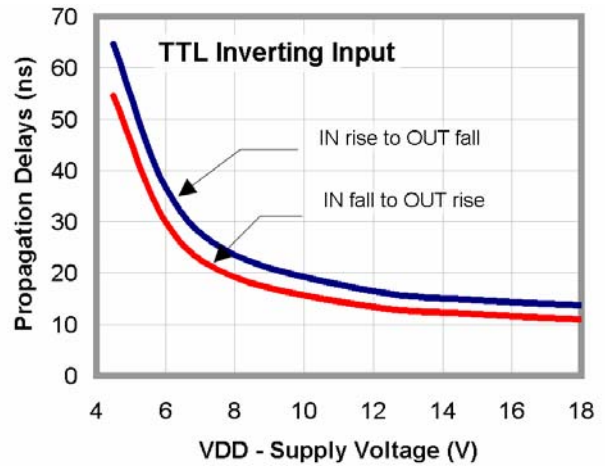

Figure 29. Propagation Delays vs. Supply Voltage

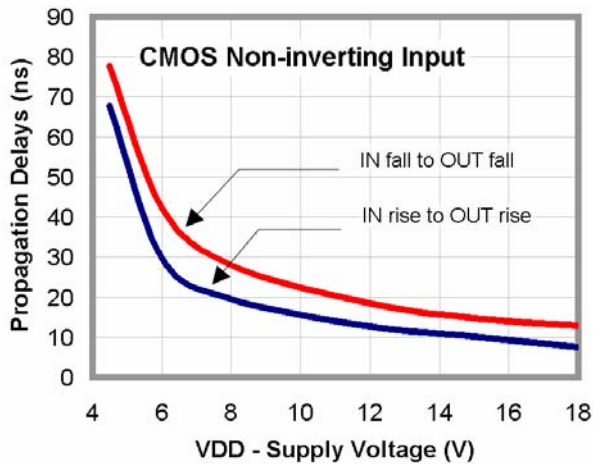

Figure 30. Propagation Delays vs. Supply Voltage

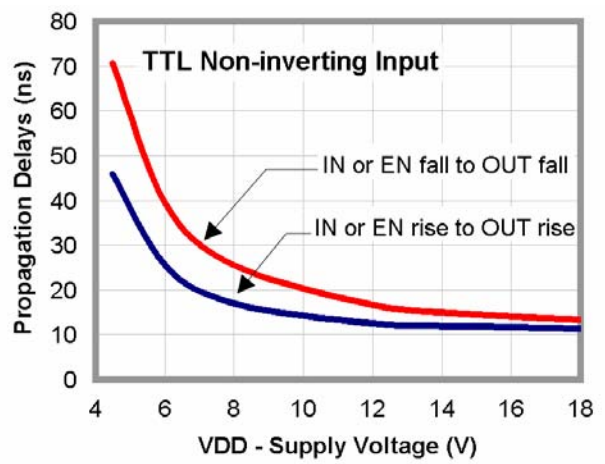

Figure 31. Propagation Delays vs. Supply Voltage

## Typical Performance Characteristics

Typical characteristics are provided at 25°C and  $V_{DD}=12V$  unless otherwise noted.

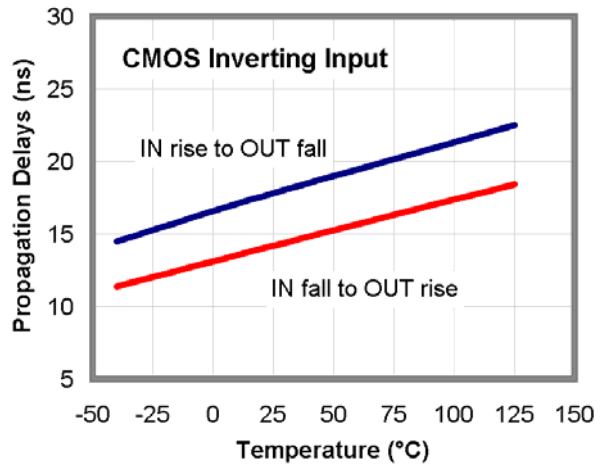

Figure 32. Propagation Delays vs. Temperature

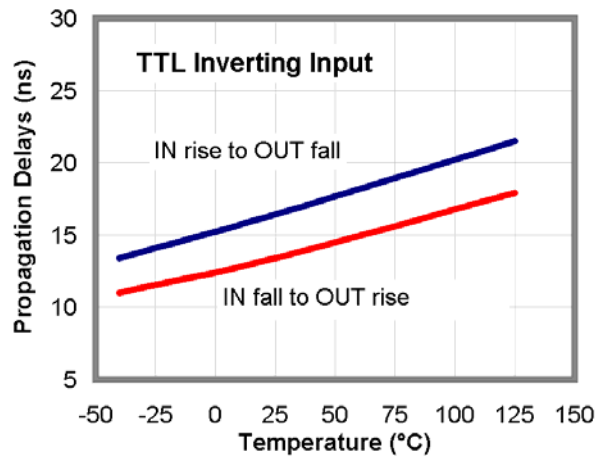

Figure 33. Propagation Delays vs. Temperature

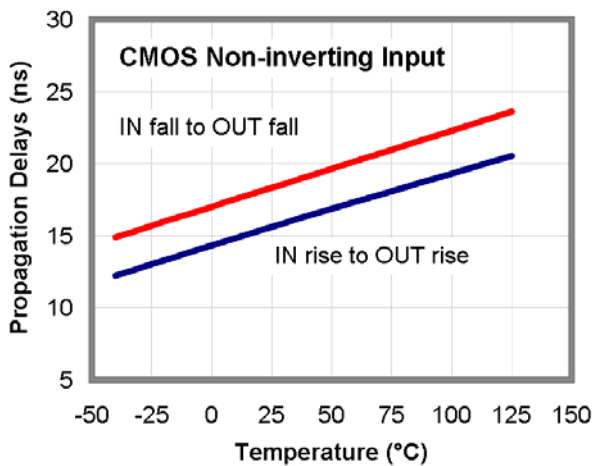

Figure 34. Propagation Delays vs. Temperature

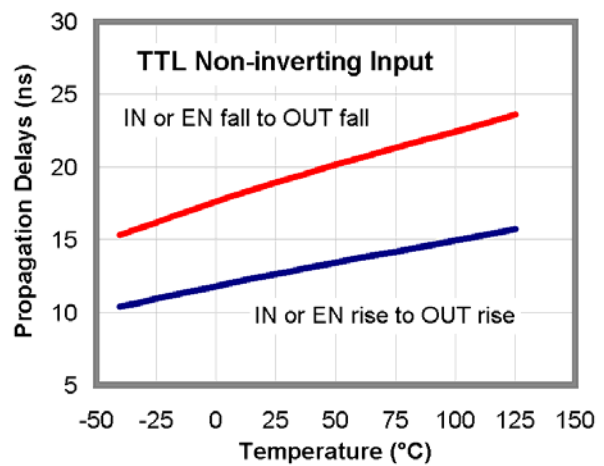

Figure 35. Propagation Delays vs. Temperature

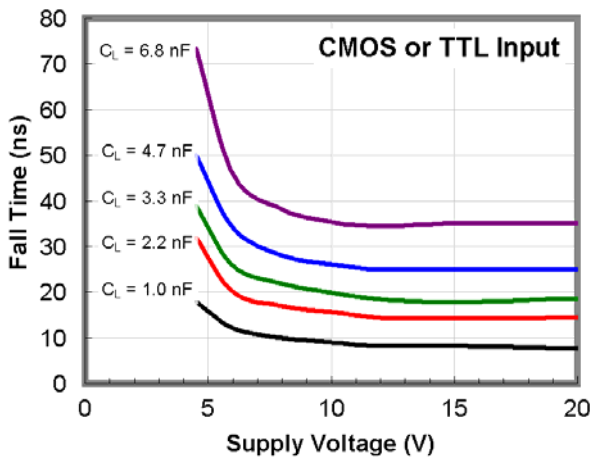

Figure 36. Fall Time vs. Supply Voltage

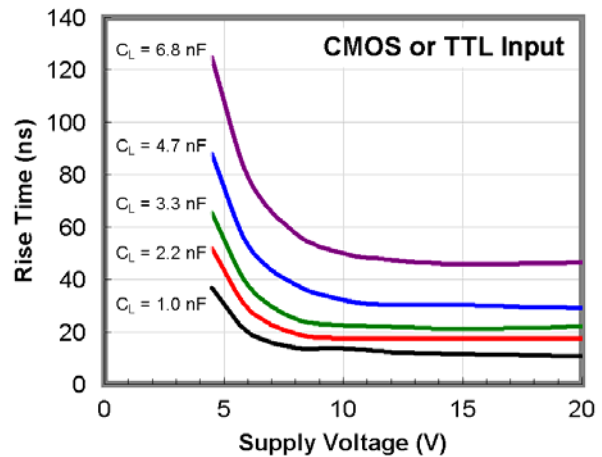

Figure 37. Rise Time vs. Supply Voltage

## Typical Performance Characteristics

Typical characteristics are provided at 25°C and  $V_{DD}=12V$  unless otherwise noted.

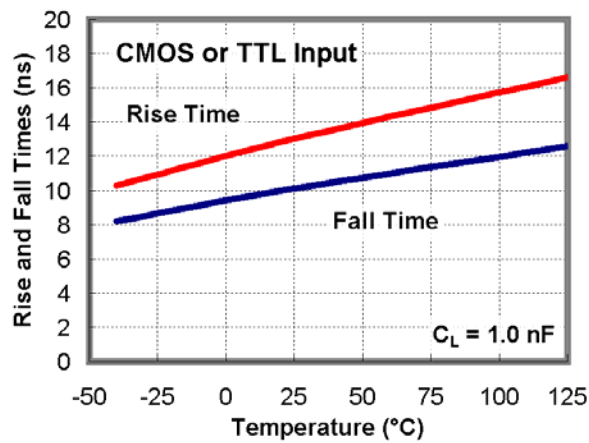

Figure 38. Rise and Fall Times vs. Temperature

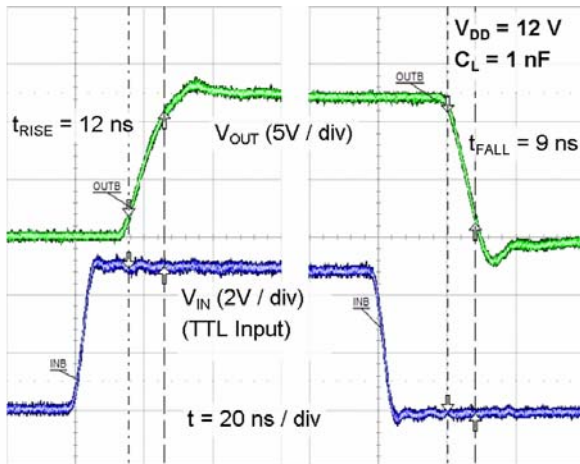

Figure 39. Rise/Fall Waveforms with 1nF Load

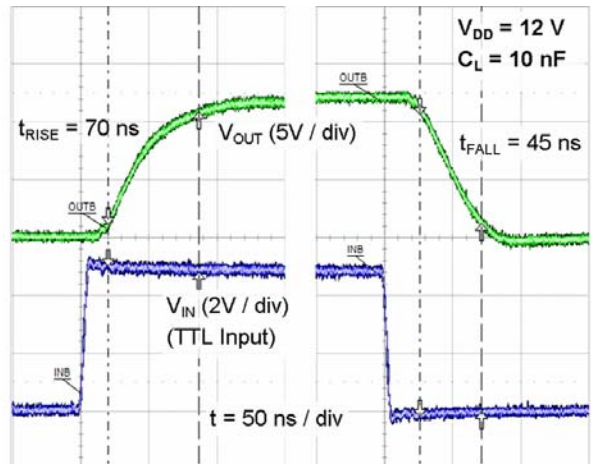

Figure 40. Rise/Fall Waveforms with 10nF Load

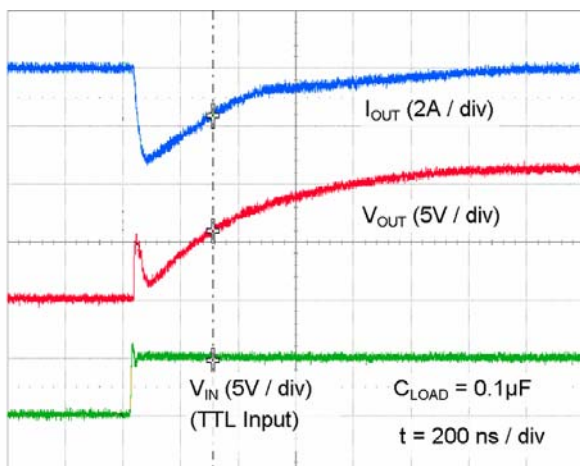

Figure 41. Quasi-Static Source Current with  $V_{DD}=12V$

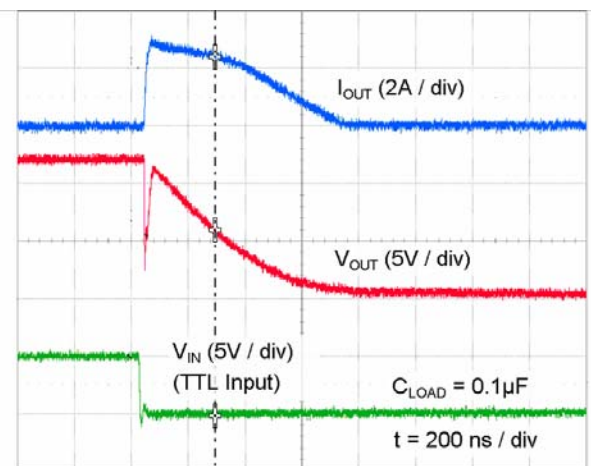

Figure 42. Quasi-Static Sink Current with  $V_{DD}=12V$

## Typical Performance Characteristics

Typical characteristics are provided at 25°C and  $V_{DD}=12V$  unless otherwise noted.

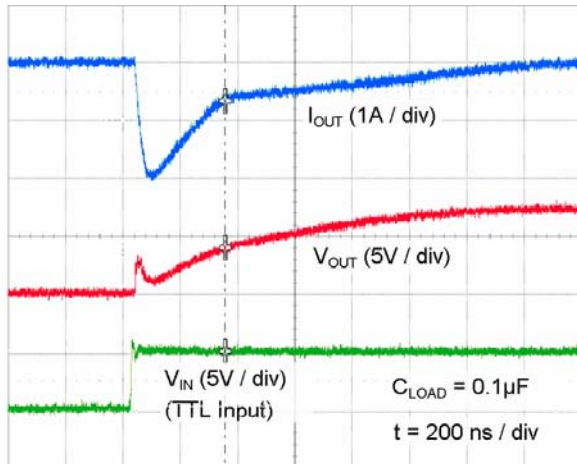

Figure 43. Quasi-Static Source Current with  $V_{DD}=8V$

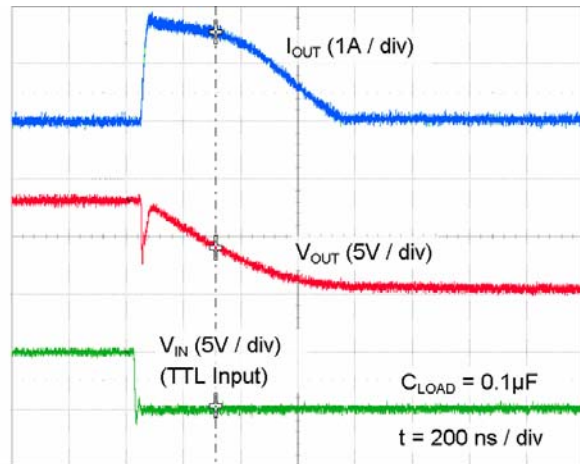

Figure 44. Quasi-Static Sink Current with  $V_{DD}=8V$

### Note:

- For any inverting inputs pulled low, non-inverting inputs pulled high, or outputs driven high, static  $I_{DD}$  increases by the current flowing through the corresponding pull-up/down resistor shown in the block diagram.

## Test Circuit

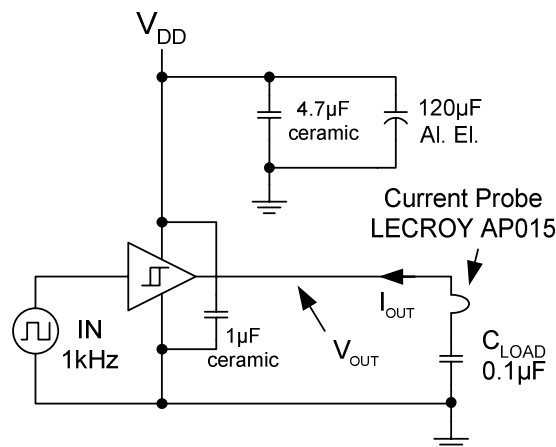

Figure 45. Quasi-Static  $I_{OUT}$  /  $V_{OUT}$  Test Circuit

## Applications Information

### Input Thresholds

Each member of the FAN322x driver family consists of two identical channels that may be used independently at rated current or connected in parallel to double the individual current capacity. In the FAN3226 and FAN3227, channels A and B can be enabled or disabled independently using ENA or ENB, respectively. The EN pin has TTL thresholds for parts with either CMOS or TTL input thresholds. If ENA and ENB are not connected, an internal pull-up resistor enables the driver channels by default. If the channel A and channel B inputs and outputs are connected in parallel to increase the driver current capacity, ENA and ENB should be connected and driven together.

The FAN322x family offers versions in either TTL or CMOS input thresholds. In the FAN322xT, the input thresholds meet industry-standard TTL-logic thresholds independent of the  $V_{DD}$  voltage, and there is a hysteresis voltage of approximately 0.4V. These levels permit the inputs to be driven from a range of input logic signal levels for which a voltage over 2V is considered logic high. The driving signal for the TTL inputs should have fast rising and falling edges with a slew rate of 6V/ $\mu$ s or faster, so a rise time from 0 to 3.3V should be 550ns or less. With reduced slew rate, circuit noise could cause the driver input voltage to exceed the hysteresis voltage and retrigger the driver input, causing erratic operation.

In the FAN322xC, the logic input thresholds are dependent on the  $V_{DD}$  level and, with  $V_{DD}$  of 12V, the logic rising edge threshold is approximately 55% of  $V_{DD}$  and the input falling edge threshold is approximately 38% of  $V_{DD}$ . The CMOS input configuration offers a hysteresis voltage of approximately 17% of  $V_{DD}$ . The CMOS inputs can be used with relatively slow edges (approaching DC) if good decoupling and bypass techniques are incorporated in the system design to prevent noise from violating the input voltage hysteresis window. This allows setting precise timing intervals by fitting an R-C circuit between the controlling signal and the IN pin of the driver. The slow rising edge at the IN pin of the driver introduces a delay between the controlling signal and the OUT pin of the driver.

### Static Supply Current

In the  $I_{DD}$  (static) typical performance characteristics (see Figure 11 - Figure 13 and Figure 18 - Figure 20), the curve is produced with all inputs / enables floating (OUT is low) and indicates the lowest static  $I_{DD}$  current for the tested configuration. For other states, additional current flows through the 100k $\Omega$  resistors on the inputs and outputs shown in the block diagram of each part (see Figure 5 - Figure 8). In these cases, the actual static  $I_{DD}$  current is the value obtained from the curves plus this additional current.

### MillerDrive™ Gate Drive Technology

FAN322x gate drivers incorporate the MillerDrive™ architecture shown in Figure 46. For the output stage, a combination of bipolar and MOS devices provide large currents over a wide range of supply voltage and temperature variations. The bipolar devices carry the bulk of the current as OUT swings between 1/3 to 2/3  $V_{DD}$  and the MOS devices pull the output to the high or low rail.

The purpose of the MillerDrive™ architecture is to speed up switching by providing high current during the Miller plateau region when the gate-drain capacitance of the MOSFET is being charged or discharged as part of the turn-on / turn-off process.

For applications that have zero voltage switching during the MOSFET turn-on or turn-off interval, the driver supplies high peak current for fast switching even though the Miller plateau is not present. This situation often occurs in synchronous rectifier applications because the body diode is generally conducting before the MOSFET is switched on.

The output pin slew rate is determined by  $V_{DD}$  voltage and the load on the output. It is not user adjustable, but a series resistor can be added if a slower rise or fall time at the MOSFET gate is needed.

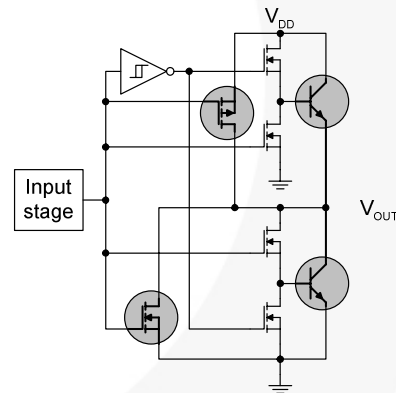

Figure 46. MillerDrive™ Output Architecture

### Under-Voltage Lockout

The FAN322x start-up logic is optimized to drive ground-referenced N-channel MOSFETs with an under-voltage lockout (UVLO) function to ensure that the IC starts up in an orderly fashion. When  $V_{DD}$  is rising, yet below the 3.9V operational level, this circuit holds the output low, regardless of the status of the input pins. After the part is active, the supply voltage must drop 0.2V before the part shuts down. This hysteresis helps prevent chatter when low  $V_{DD}$  supply voltages have noise from the power switching. This configuration is not suitable for driving high-side P-channel MOSFETs because the low output voltage of the driver would turn the P-channel MOSFET on with  $V_{DD}$  below 3.9V.



## V<sub>DD</sub> Bypass Capacitor Guidelines

To enable this IC to turn a device on quickly, a local high-frequency bypass capacitor  $C_{BYP}$  with low ESR and ESL should be connected between the V<sub>DD</sub> and GND pins with minimal trace length. This capacitor is in addition to bulk electrolytic capacitance of 10 $\mu$ F to 47 $\mu$ F commonly found on driver and controller bias circuits.

A typical criterion for choosing the value of  $C_{BYP}$  is to keep the ripple voltage on the V<sub>DD</sub> supply to  $\leq 5\%$ . This is often achieved with a value  $\geq 20$  times the equivalent load capacitance  $C_{EQV}$ , defined here as  $Q_{GATE}/V_{DD}$ . Ceramic capacitors of 0.1 $\mu$ F to 1 $\mu$ F or larger are common choices, as are dielectrics, such as X5R and X7R with good temperature characteristics and high pulse current capability.

If circuit noise affects normal operation, the value of  $C_{BYP}$  may be increased to 50-100 times the  $C_{EQV}$ , or  $C_{BYP}$  may be split into two capacitors. One should be a larger value, based on equivalent load capacitance, and the other a smaller value, such as 1-10nF mounted closest to the V<sub>DD</sub> and GND pins to carry the higher frequency components of the current pulses. The bypass capacitor must provide the pulsed current from both of the driver channels and, if the drivers are switching simultaneously, the combined peak current sourced from the  $C_{BYP}$  would be twice as large as when a single channel is switching.

## Layout and Connection Guidelines

The FAN3226-26 family of gate drivers incorporates fast-reacting input circuits, short propagation delays, and powerful output stages capable of delivering current peaks over 2A to facilitate voltage transition times from under 10ns to over 150ns. The following layout and connection guidelines are strongly recommended:

- Keep high-current output and power ground paths separate logic and enable input signals and signal ground paths. This is especially critical when dealing with TTL-level logic thresholds at driver inputs and enable pins.
- Keep the driver as close to the load as possible to minimize the length of high-current traces. This reduces the series inductance to improve high-speed switching, while reducing the loop area that can radiate EMI to the driver inputs and surrounding circuitry.
- If the inputs to a channel are not externally connected, the internal 100k $\Omega$  resistors indicated on block diagrams command a low output. In noisy environments, it may be necessary to tie inputs of an unused channel to V<sub>DD</sub> or GND using short traces to prevent noise from causing spurious output switching.
- Many high-speed power circuits can be susceptible to noise injected from their own output or other external sources, possibly causing output re-triggering. These effects can be obvious if the circuit is tested in breadboard or non-optimal circuit layouts with long input, enable, or output leads. For

best results, make connections to all pins as short and direct as possible.

- The FAN322x is compatible with many other industry-standard drivers. In single input parts with enable pins, there is an internal 100k $\Omega$  resistor tied to V<sub>DD</sub> to enable the driver by default; this should be considered in the PCB layout.
- The turn-on and turn-off current paths should be minimized, as discussed in the following section.

Figure 47 shows the pulsed gate drive current path when the gate driver is supplying gate charge to turn the MOSFET on. The current is supplied from the local bypass capacitor,  $C_{BYP}$ , and flows through the driver to the MOSFET gate and to ground. To reach the high peak currents possible, the resistance and inductance in the path should be minimized. The localized  $C_{BYP}$  acts to contain the high peak current pulses within this driver-MOSFET circuit, preventing them from disturbing the sensitive analog circuitry in the PWM controller.

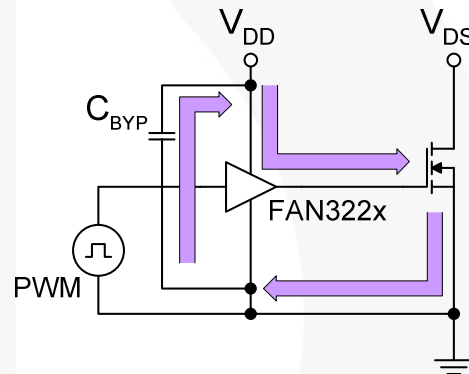

Figure 47. Current Path for MOSFET Turn-on

Figure 48 shows the current path when the gate driver turns the MOSFET off. Ideally, the driver shunts the current directly to the source of the MOSFET in a small circuit loop. For fast turn-off times, the resistance and inductance in this path should be minimized.

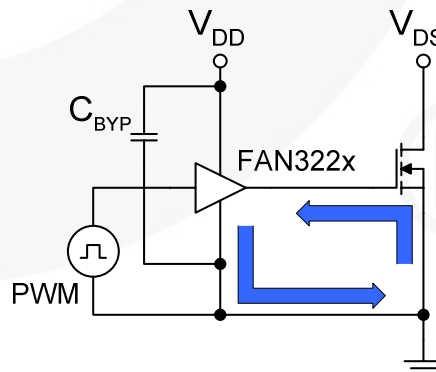

Figure 48. Current Path for MOSFET Turn-off

### Truth Table of Logic Operation

The FAN3228/FAN3229 truth table indicates the operational states using the dual-input configuration. In a non-inverting driver configuration, the IN- pin should be a logic low signal. If the IN- pin is connected to logic high, a disable function is realized, and the driver output remains low regardless of the state of the IN+ pin.

IN+	IN-	OUT
0	0	0
0	1	0
1	0	1
1	1	0

In the non-inverting driver configuration in Figure 49, the IN- pin is tied to ground and the input signal (PWM) is applied to IN+ pin. The IN- pin can be connected to logic high to disable the driver and the output remains low, regardless of the state of the IN+ pin.

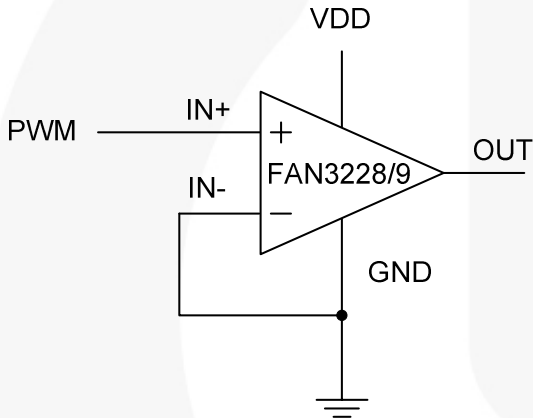

**Figure 49. Dual-Input Driver Enabled, Non-Inverting Configuration**

In the inverting driver application in Figure 50, the IN+ pin is tied high. Pulling the IN+ pin to GND forces the output low, regardless of the state of the IN- pin.

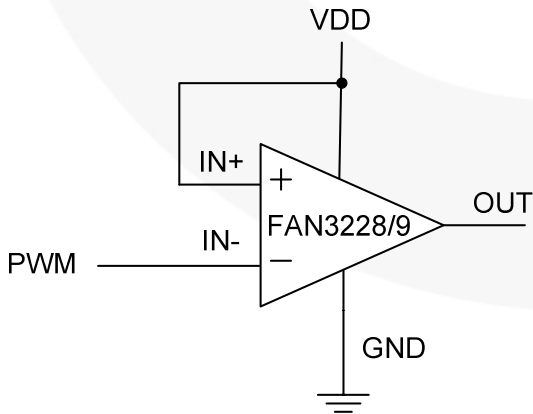

**Figure 50. Dual-Input Driver Enabled, Inverting Configuration**

### Operational Waveforms

At power-up, the driver output remains low until the  $V_{DD}$  voltage reaches the turn-on threshold. The magnitude of the OUT pulses rises with  $V_{DD}$  until steady-state  $V_{DD}$  is reached. The non-inverting operation illustrated in Figure 51 shows that the output remains low until the UVLO threshold is reached, the output is in-phase with the input.

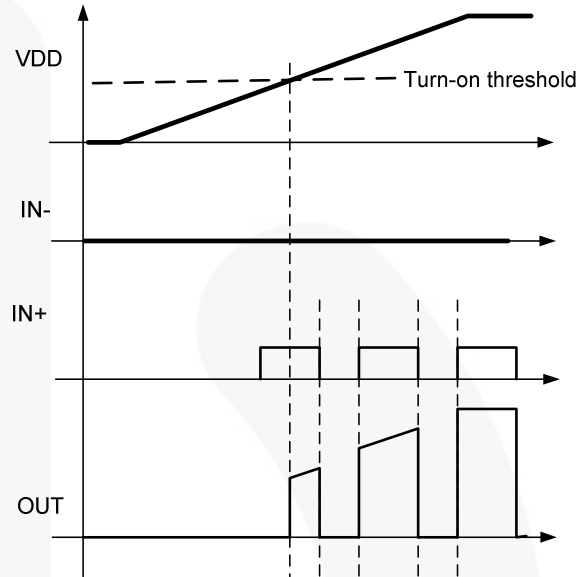

**Figure 51. Non-Inverting Start-Up Waveforms**

For the inverting configuration of Figure 50, start-up waveforms are shown in Figure 52. With IN+ tied to  $V_{DD}$  and the input signal applied to IN-, the OUT pulses are inverted with respect to the input. At power-up, the inverted output remains low until the  $V_{DD}$  voltage reaches the turn-on threshold, then it follows the input with inverted phase.

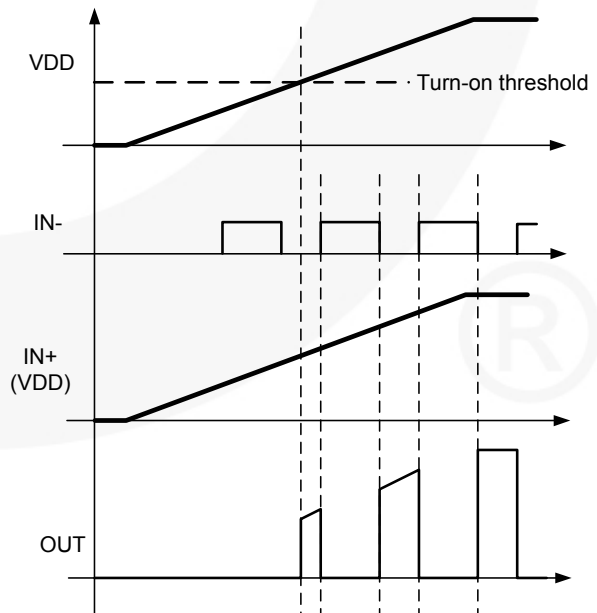

**Figure 52. Inverting Start-Up Waveforms**

## Thermal Guidelines

Gate drivers used to switch MOSFETs and IGBTs at high frequencies can dissipate significant amounts of power. It is important to determine the driver power dissipation and the resulting junction temperature in the application to ensure that the part is operating within acceptable temperature limits.

The total power dissipation in a gate driver is the sum of two components,  $P_{GATE}$  and  $P_{DYNAMIC}$ :

$$P_{TOTAL} = P_{GATE} + P_{DYNAMIC} \quad (1)$$

**Gate Driving Loss:** The most significant power loss results from supplying gate current (charge per unit time) to switch the load MOSFET on and off at the switching frequency. The power dissipation that results from driving a MOSFET at a specified gate-source voltage,  $V_{GS}$ , with gate charge,  $Q_G$ , at switching frequency,  $F_{SW}$ , is determined by:

$$P_{GATE} = Q_G \cdot V_{GS} \cdot F_{SW} \cdot n \quad (2)$$

$n$  is the number of driver channels in use (1 or 2).

**Dynamic Pre-drive / Shoot-through Current:** A power loss resulting from internal current consumption under dynamic operating conditions, including pin pull-up / pull-down resistors, can be obtained using the graphs in Typical Performance Characteristics to determine the current  $I_{DYNAMIC}$  drawn from  $V_{DD}$  under actual operating conditions:

$$P_{DYNAMIC} = I_{DYNAMIC} \cdot V_{DD} \cdot n \quad (3)$$

Once the power dissipated in the driver is determined, the driver junction rise with respect to circuit board can be evaluated using the following thermal equation, assuming  $\Psi_{JB}$  was determined for a similar thermal design (heat sinking and air flow):

$$T_J = P_{TOTAL} \cdot \Psi_{JB} + T_B \quad (4)$$

where:

$T_J$  = driver junction temperature

$\Psi_{JB}$  = (psi) thermal characterization parameter relating temperature rise to total power dissipation

$T_B$  = board temperature in location defined in Note 1 under Thermal Resistance table.

In the forward converter with synchronous rectifier shown in the typical application diagrams, the FDMS8660S is a reasonable MOSFET selection. The gate charge for each SR MOSFET would be 60nC with  $V_{GS} = V_{DD} = 7V$ . At a switching frequency of 500kHz, the total power dissipation is:

$$P_{GATE} = 60nC \cdot 7V \cdot 500kHz \cdot 2 = 0.42W \quad (5)$$

$$P_{DYNAMIC} = 3mA \cdot 7V \cdot 2 = 0.042W \quad (6)$$

$$P_{TOTAL} = 0.46W \quad (7)$$

The SOIC-8 has a junction-to-board thermal characterization parameter of  $\Psi_{JB} = 43^\circ C/W$ . In a system application, the localized temperature around the device is a function of the layout and construction of the PCB along with airflow across the surfaces. To ensure reliable operation, the maximum junction temperature of the device must be prevented from exceeding the maximum rating of  $150^\circ C$ ; with 80% derating,  $T_J$  would be limited to  $120^\circ C$ . Rearranging Equation 4 determines the board temperature required to maintain the junction temperature below  $120^\circ C$ :

$$T_B = T_J - P_{TOTAL} \cdot \Psi_{JB} \quad (8)$$

$$T_B = 120^\circ C - 0.46W \cdot 43^\circ C/W = 100^\circ C \quad (9)$$

For comparison, replace the SOIC-8 used in the previous example with the 3x3mm MLP package with  $\Psi_{JB} = 3.5^\circ C/W$ . The 3x3mm MLP package could operate at a PCB temperature of  $118^\circ C$ , while maintaining the junction temperature below  $120^\circ C$ . This illustrates that the physically smaller MLP package with thermal pad offers a more conductive path to remove the heat from the driver. Consider tradeoffs between reducing overall circuit size with junction temperature reduction for increased reliability.

Typical Application Diagrams

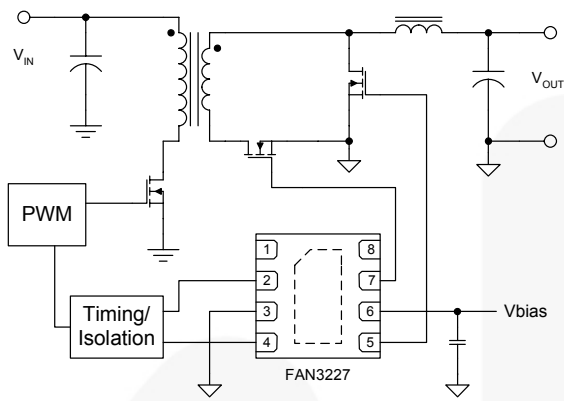

Figure 53. Forward Converter with Synchronous Rectification

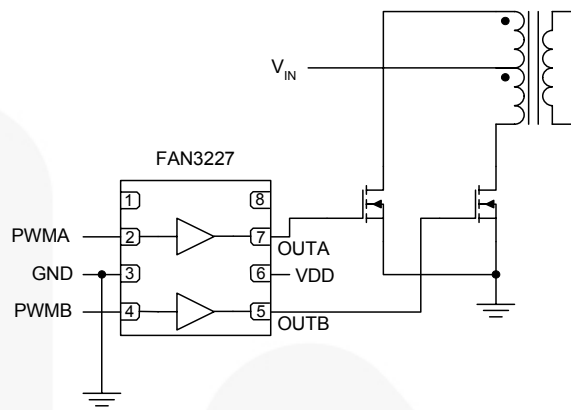

Figure 54. Primary-side Dual Driver in a Push-pull Converter

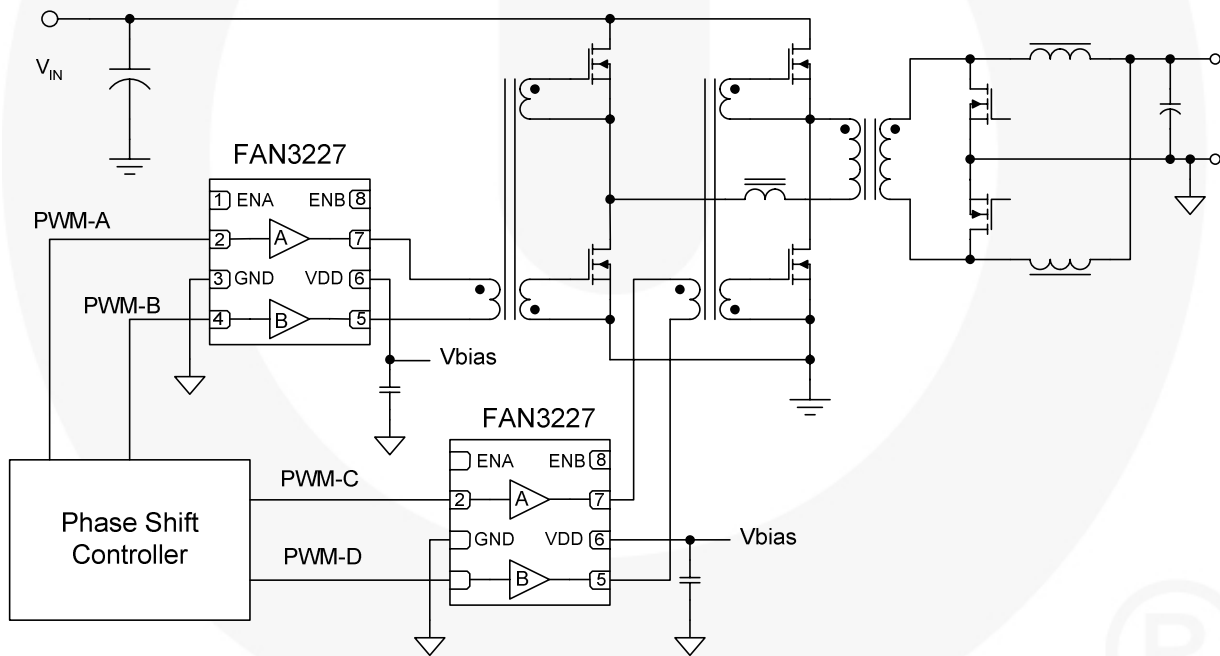

Figure 55. Phase-shifted Full-bridge with Two Gate Drive Transformers (Simplified)

**Table 1. Related Products**

Part Number	Type	Gate Drive <sup>(13)</sup> (Sink/Src)	Input Threshold	Logic	Package
FAN3100C	Single 2A	+2.5A / -1.8A	CMOS	Single Channel of Two-Input/One-Output	SOT23-5, MLP6
FAN3100T	Single 2A	+2.5A / -1.8A	TTL	Single Channel of Two-Input/One-Output	SOT23-5, MLP6
<b>FAN3226C</b>	<b>Dual 2A</b>	<b>+2.4A / -1.6A</b>	<b>CMOS</b>	<b>Dual Inverting Channels + Dual Enable</b>	<b>SOIC8, MLP8</b>
<b>FAN3226T</b>	<b>Dual 2A</b>	<b>+2.4A / -1.6A</b>	<b>TTL</b>	<b>Dual Inverting Channels + Dual Enable</b>	<b>SOIC8, MLP8</b>
<b>FAN3227C</b>	<b>Dual 2A</b>	<b>+2.4A / -1.6A</b>	<b>CMOS</b>	<b>Dual Non-Inverting Channels + Dual Enable</b>	<b>SOIC8, MLP8</b>
<b>FAN3227T</b>	<b>Dual 2A</b>	<b>+2.4A / -1.6A</b>	<b>TTL</b>	<b>Dual Non-Inverting Channels + Dual Enable</b>	<b>SOIC8, MLP8</b>
<b>FAN3228C</b>	<b>Dual 2A</b>	<b>+2.4A / -1.6A</b>	<b>CMOS</b>	<b>Dual Channels of Two-Input/One-Output, Pin Config.1</b>	<b>SOIC8, MLP8</b>
<b>FAN3228T</b>	<b>Dual 2A</b>	<b>+2.4A / -1.6A</b>	<b>TTL</b>	<b>Dual Channels of Two-Input/One-Output, Pin Config.1</b>	<b>SOIC8, MLP8</b>
<b>FAN3229C</b>	<b>Dual 2A</b>	<b>+2.4A / -1.6A</b>	<b>CMOS</b>	<b>Dual Channels of Two-Input/One-Output, Pin Config.2</b>	<b>SOIC8, MLP8</b>
<b>FAN3229T</b>	<b>Dual 2A</b>	<b>+2.4A / -1.6A</b>	<b>TTL</b>	<b>Dual Channels of Two-Input/One-Output, Pin Config.2</b>	<b>SOIC8, MLP8</b>
FAN3223C	Dual 4A	+4.3A / -2.8A	CMOS	Dual Inverting Channels + Dual Enable	SOIC8, MLP8
FAN3223T	Dual 4A	+4.3A / -2.8A	TTL	Dual Inverting Channels + Dual Enable	SOIC8, MLP8
FAN3224C	Dual 4A	+4.3A / -2.8A	CMOS	Dual Non-Inverting Channels + Dual Enable	SOIC8, MLP8
FAN3224T	Dual 4A	+4.3A / -2.8A	TTL	Dual Non-Inverting Channels + Dual Enable	SOIC8, MLP8
FAN3225C	Dual 4A	+4.3A / -2.8A	CMOS	Dual Channels of Two-Input/One-Output	SOIC8, MLP8
FAN3225T	Dual 4A	+4.3A / -2.8A	TTL	Dual Channels of Two-Input/One-Output	SOIC8, MLP8

**Note:**13. Typical currents with OUT at 6V and  $V_{DD} = 12V$ .



Physical Dimensions (Continued)

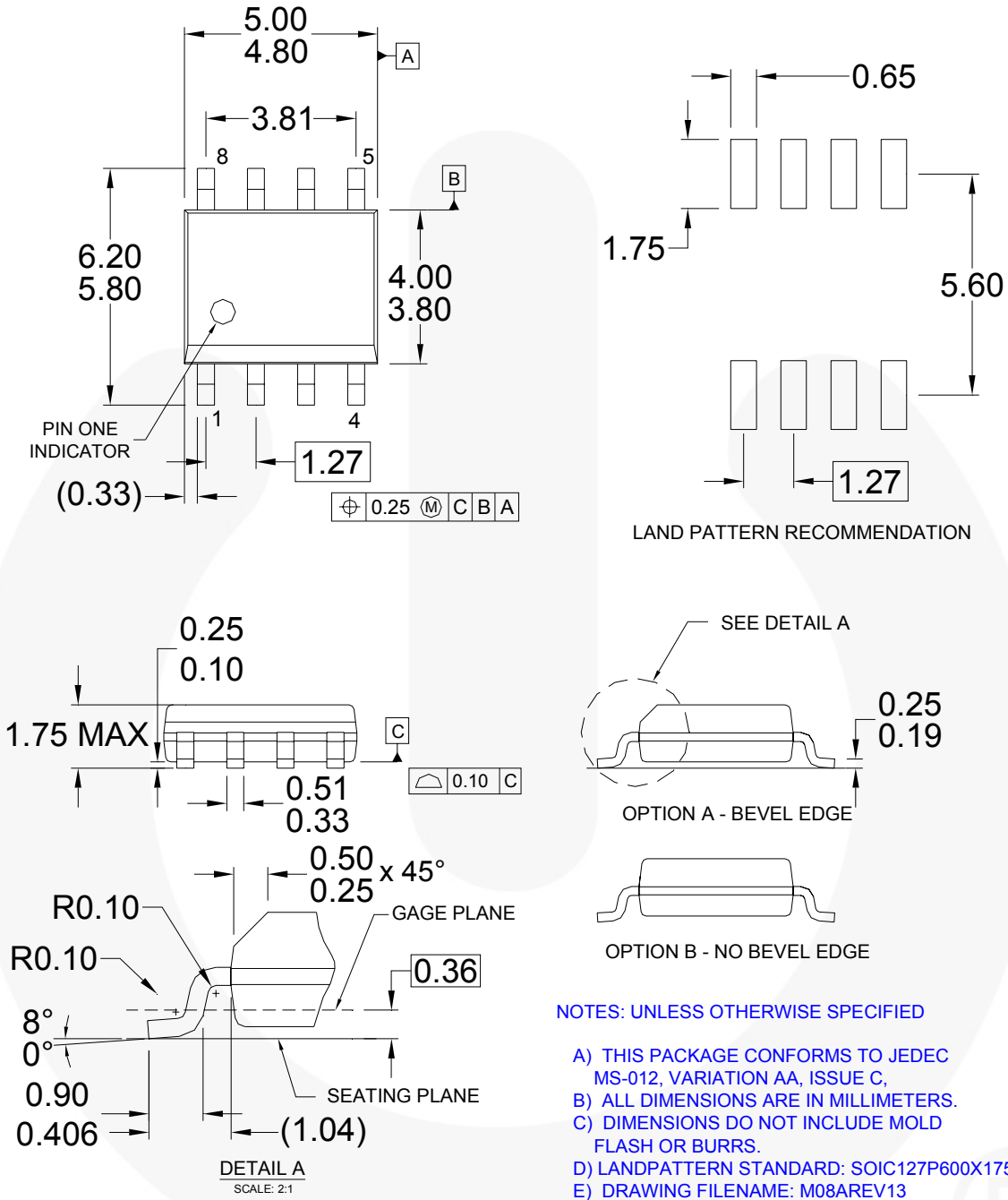

Figure 57. 8-Lead SOIC



Package drawings are provided as a service to customers considering Fairchild components. Drawings may change in any manner without notice. Please note the revision and/or date on the drawing and contact a Fairchild Semiconductor representative to verify or obtain the most recent revision. Package specifications do not expand the terms of Fairchild's worldwide terms and conditions, specifically the warranty therein, which covers Fairchild products.

Always visit Fairchild Semiconductor's online packaging area for the most recent package drawings:  
<http://www.fairchildsemi.com/packaging/>



**TRADEMARKS**

The following includes registered and unregistered trademarks and service marks, owned by Fairchild Semiconductor and/or its global subsidiaries, and is not intended to be an exhaustive list of all such trademarks.

- |   |  |  |                                  |
|---|--|--|----------------------------------|
| ACEX <sup>®</sup>   | FPS <sup>™</sup>                             | PDP-SPM <sup>™</sup>                   | SupreMOS <sup>™</sup>            |
| Build it Now <sup>™</sup>   | FRFET <sup>®</sup>                           | Power220 <sup>®</sup>                  | SyncFET <sup>™</sup>             |
| CorePLUS <sup>™</sup>   | Global Power Resource <sup>SM</sup>          | POWEREDGE <sup>®</sup>                 | SYSTEM <sup>®</sup>              |
| CROSSVOL <sup>™</sup>   | Green FPS <sup>™</sup>                       | Power-SPM <sup>™</sup>                 | GENERAL <sup>®</sup>             |
| CTL <sup>™</sup>  | Green FPS <sup>™</sup> e-Series <sup>™</sup> | PowerTrench <sup>®</sup>               | The Power Franchise <sup>®</sup> |
| Current Transfer Logic <sup>™</sup>   | GTO <sup>™</sup>                             | Programmable Active Droop <sup>™</sup> | the power franchise <sup>®</sup> |
| EcoSPARK <sup>®</sup>   | i-Lo <sup>™</sup>                            | QFET <sup>®</sup>                      | TinyBoost <sup>™</sup>           |
| EZSWITCH <sup>™</sup> *   | IntelliMAX <sup>™</sup>                      | QS <sup>™</sup>                        | TinyBuck <sup>™</sup>            |
|  | ISOPLANAR <sup>™</sup>                       | QT Optoelectronics <sup>™</sup>        | TinyLogic <sup>®</sup>           |
|  | MegaBuck <sup>™</sup>                        | Quiet Series <sup>™</sup>              | TINYOPTO <sup>™</sup>            |
| Fairchild <sup>®</sup>  | MICROCOUPLER <sup>™</sup>                    | RapidConfigure <sup>™</sup>            | TinyPower <sup>™</sup>           |
| Fairchild Semiconductor <sup>®</sup>  | MicroFET <sup>™</sup>                        | SMART START <sup>™</sup>               | TinyPWM <sup>™</sup>             |
| FACT Quiet Series <sup>™</sup>  | MicroPak <sup>™</sup>                        | SPM <sup>®</sup>                       | TinyWire <sup>™</sup>            |
| FACT <sup>®</sup>   | MillerDrive <sup>™</sup>                     | STEALTH <sup>™</sup>                   | μSerDes <sup>™</sup>             |
| FAST <sup>®</sup>   | Motion-SPM <sup>™</sup>                      | SuperFET <sup>™</sup>                  | UHC <sup>®</sup>                 |
| FastvCore <sup>™</sup>  | OPTOLOGIC <sup>®</sup>                       | SuperSOT <sup>™</sup> .3               | Ultra FRFET <sup>™</sup>         |
| FlashWriter <sup>®</sup> *  | OPTOPLANAR <sup>®</sup>                      | SuperSOT <sup>™</sup> .6               | UniFET <sup>™</sup>              |
|   |  | SuperSOT <sup>™</sup> .8               | VCX <sup>™</sup>                 |

\* EZSWITCH<sup>™</sup> and FlashWriter<sup>®</sup> are trademarks of System General Corporation, used under license by Fairchild Semiconductor.

**DISCLAIMER**

FAIRCHILD SEMICONDUCTOR RESERVES THE RIGHT TO MAKE CHANGES WITHOUT FURTHER NOTICE TO ANY PRODUCTS HEREIN TO IMPROVE RELIABILITY, FUNCTION, OR DESIGN. FAIRCHILD DOES NOT ASSUME ANY LIABILITY ARISING OUT OF THE APPLICATION OR USE OF ANY PRODUCT OR CIRCUIT DESCRIBED HEREIN; NEITHER DOES IT CONVEY ANY LICENSE UNDER ITS PATENT RIGHTS, NOR THE RIGHTS OF OTHERS. THESE SPECIFICATIONS DO NOT EXPAND THE TERMS OF FAIRCHILD'S WORLDWIDE TERMS AND CONDITIONS, SPECIFICALLY THE WARRANTY THEREIN, WHICH COVERS THESE PRODUCTS.

**LIFE SUPPORT POLICY**

FAIRCHILD'S PRODUCTS ARE NOT AUTHORIZED FOR USE AS CRITICAL COMPONENTS IN LIFE SUPPORT DEVICES OR SYSTEMS WITHOUT THE EXPRESS WRITTEN APPROVAL OF FAIRCHILD SEMICONDUCTOR CORPORATION.

As used herein:

- Life support devices or systems are devices or systems which, (a) are intended for surgical implant into the body or (b) support or sustain life, and (c) whose failure to perform when properly used in accordance with instructions for use provided in the labeling, can be reasonably expected to result in a significant injury of the user.
- A critical component in any component of a life support, device, or system whose failure to perform can be reasonably expected to cause the failure of the life support device or system, or to affect its safety or effectiveness.

**PRODUCT STATUS DEFINITIONS**

**Definition of Terms**

Datasheet Identification	Product Status	Definition
Advance Information	Formative or In Design	This datasheet contains the design specifications for product development. Specifications may change in any manner without notice.
Preliminary	First Production	This datasheet contains preliminary data; supplementary data will be published at a later date. Fairchild Semiconductor reserves the right to make changes at any time without notice to improve design.
No Identification Needed	Full Production	This datasheet contains final specifications. Fairchild Semiconductor reserves the right to make changes at any time without notice to improve the design.
Obsolete	Not In Production	This datasheet contains specifications on a product that has been discontinued by Fairchild Semiconductor. The datasheet is printed for reference information only.

Rev. I33