

# ES3A - ES3J

## Fast Rectifiers

### Features

- For surface mount applications.
- Glass passivated junction.
- Low profile package.
- Easy pick and place.
- Built-in strain relief.
- Superfast recovery times for high efficiency.

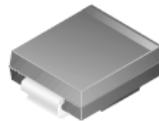

**SMC/DO-214AB**  
Color Band Denotes Cathode

### Absolute Maximum Ratings \* T<sub>a</sub> = 25°C unless otherwise noted

Symbol	Parameter	Value					Units
		ES3A	ES3B	ES3C	ES3D	ES3J	
V <sub>RRM</sub>	Maximum Repetitive Reverse Voltage	50	100	150	200	600	V
I <sub>F(AV)</sub>	Average Rectified Forward Current, .375" lead length @ T <sub>A</sub> =75°C	3.0					A
I <sub>FSM</sub>	Non-repetitive Peak Forward Surge Current 8.3 ms Single Half-Sine-Wave	100					A
T <sub>J</sub> , T <sub>STG</sub>	Operating Junction and Storage Temperature Range	-50 to +150					°C
P <sub>D</sub>	Power Dissipation	1.66					W

\* These ratings are limiting values above which the serviceability of any semiconductor device may be impaired.

### Thermal Characteristics

Symbol	Parameter	Value	Units
R <sub>θJA</sub>	Thermal Resistance, Junction to Ambient *	47	°C/W
R <sub>θJL</sub>	Thermal Resistance, Junction to Lead *	12	°C/W

\* Device mounted on FR-4 PCB 0.013 mm.

### Electrical Characteristics T<sub>C</sub> = 25°C unless otherwise noted

Symbol	Parameter	Value	Units
V <sub>F</sub>	Forward Voltage @ I <sub>F</sub> = 3.0 A	0.95	1.7 V
T <sub>rr</sub>	Reverse Recovery Time I <sub>F</sub> = 0.5 A, I <sub>R</sub> = 1.0 A, I <sub>RR</sub> = 0.25 A	20	35 ns
I <sub>R</sub>	Reverse Current @ rated V <sub>R</sub> T <sub>A</sub> = 25°C T <sub>A</sub> = 100°C	10 500	uA
C <sub>T</sub>	Total Capacitance V <sub>R</sub> = 4.0 V, f = 1.0 MHz	45	pF

### Typical Performance Characteristics

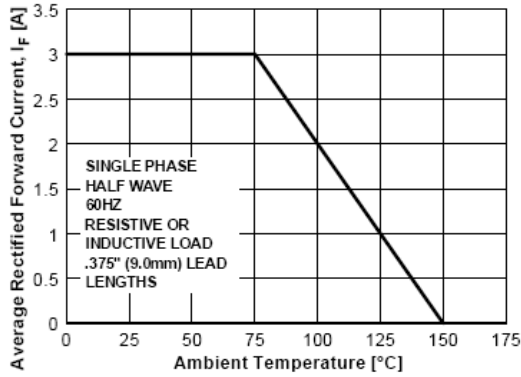

Figure 1. Forward Current Deration Curve

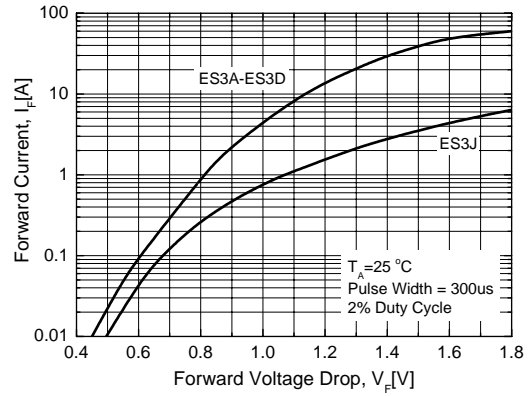

Figure 2. Forward Voltage Characteristics

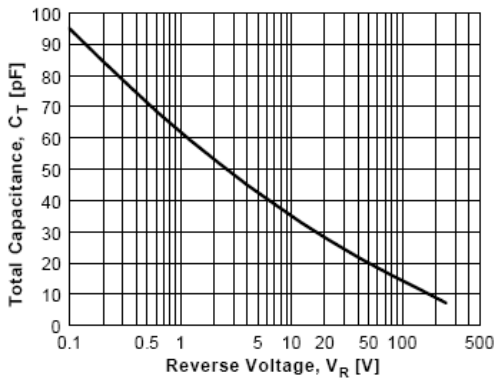

Figure 3. Total Capacitance

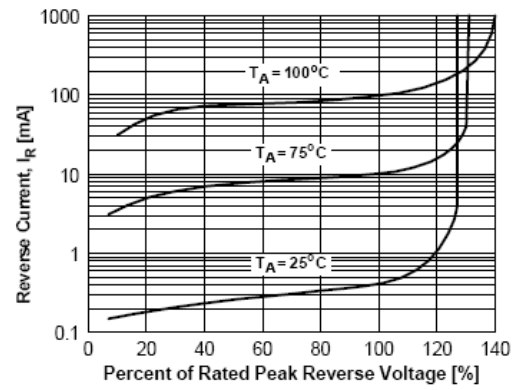
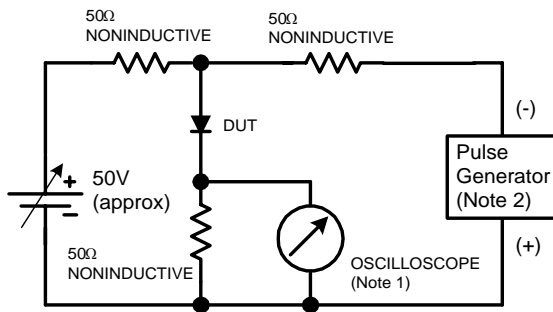
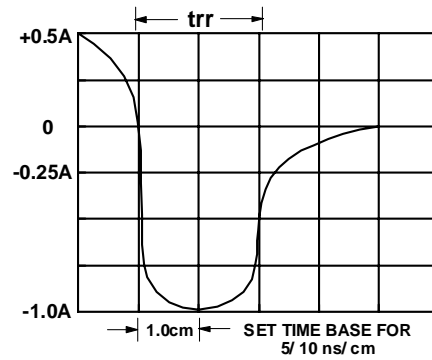

Figure 4. Reverse Current vs Reverse Voltage



**NOTES:**

1. Rise time = 7.0 ns max; Input impedance = 1.0 megaohm 22 pf.
2. Rise time = 10 ns max; Source impedance = 50 ohms.



Package Dimensions

SMC / DO - 214AB

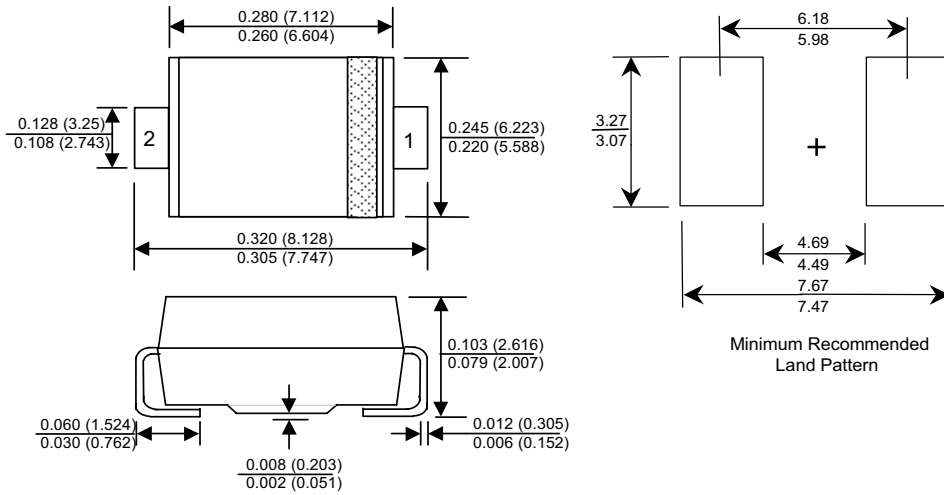

Dimensions in Inches(Millimeters)

**FAIRCHILD SEMICONDUCTOR TRADEMARKS**

The following are registered and unregistered trademarks Fairchild Semiconductor owns or is authorized to use and is not intended to be an exhaustive list of all such trademarks.

ACEx™	FACT Quiet Series™	OCX™	SILENT SWITCHER®	UniFET™
ActiveArray™	GlobalOptoisolator™	OCXPro™	SMART START™	VCX™
Bottomless™	GTO™	OPTOLOGIC®	SPM™	Wire™
Build it Now™	HiSeC™	OPTOPLANAR™	Stealth™	
CoolFET™	I <sup>2</sup> C™	PACMAN™	SuperFET™	
CROSSVOLT™	i-Lo™	POPT™	SuperSOT™-3	
DOMETM	ImpliedDisconnect™	Power247™	SuperSOT™-6	
EcoSPARK™	IntelliMAX™	PowerEdge™	SuperSOT™-8	
E <sup>2</sup> C MOS™	ISOPLANAR™	PowerSaver™	SyncFET™	
EnSigna™	LittleFET™	PowerTrench®	TCM™	
FACT®	MICROCOUPLER™	QFET®	TinyBoost™	
FAST®	MicroFET™	QS™	TinyBuck™	
FASTr™	MicroPak™	QT Optoelectronics™	TinyPWM™	
FPS™	MICROWIRE™	Quiet Series™	TinyPower™	
FRFET™	MSX™	RapidConfigure™	TinyLogic®	
	MSXPro™	RapidConnect™	TINYOPTO™	
Across the board. Around the world.™		μSerDes™	TruTranslation™	
The Power Franchise®		ScalarPump™	UHC®	
Programmable Active Droop™				

**DISCLAIMER**

FAIRCHILD SEMICONDUCTOR RESERVES THE RIGHT TO MAKE CHANGES WITHOUT FURTHER NOTICE TO ANY PRODUCTS HEREIN TO IMPROVE RELIABILITY, FUNCTION OR DESIGN. FAIRCHILD DOES NOT ASSUME ANY LIABILITY ARISING OUT OF THE APPLICATION OR USE OF ANY PRODUCT OR CIRCUIT DESCRIBED HEREIN; NEITHER DOES IT CONVEY ANY LICENSE UNDER ITS PATENT RIGHTS, NOR THE RIGHTS OF OTHERS. THESE SPECIFICATIONS DO NOT EXPAND THE TERMS OF FAIRCHILD'S WORLDWIDE TERMS AND CONDITIONS, SPECIFICALLY THE WARRANTY THEREIN, WHICH COVERS THESE PRODUCTS.

**LIFE SUPPORT POLICY**

FAIRCHILD'S PRODUCTS ARE NOT AUTHORIZED FOR USE AS CRITICAL COMPONENTS IN LIFE SUPPORT DEVICES OR SYSTEMS WITHOUT THE EXPRESS WRITTEN APPROVAL OF FAIRCHILD SEMICONDUCTOR CORPORATION.

As used herein:

- Life support devices or systems are devices or systems which, (a) are intended for surgical implant into the body, or (b) support or sustain life, or (c) whose failure to perform when properly used in accordance with instructions for use provided in the labeling, can be reasonably expected to result in significant injury to the user.
- A critical component is any component of a life support device or system whose failure to perform can be reasonably expected to cause the failure of the life support device or system, or to affect its safety or effectiveness.

**PRODUCT STATUS DEFINITIONS**

**Definition of Terms**

Datasheet Identification	Product Status	Definition
Advance Information	Formative or In Design	This datasheet contains the design specifications for product development. Specifications may change in any manner without notice.
Preliminary	First Production	This datasheet contains preliminary data, and supplementary data will be published at a later date. Fairchild Semiconductor reserves the right to make changes at any time without notice in order to improve design.
No Identification Needed	Full Production	This datasheet contains final specifications. Fairchild Semiconductor reserves the right to make changes at any time without notice in order to improve design.
Obsolete	Not In Production	This datasheet contains specifications on a product that has been discontinued by Fairchild semiconductor. The datasheet is printed for reference information only.

Rev. I22